



2024 & 2028 Draft LCR Study Results Stockton Area

Subrina Sultana Noureen

Regional Transmission Engineer

Stakeholder Call

March 9, 2023

New major transmission projects

Projects	Expected ISD
Mosher Transmission Project	Dec-27
Vierra 115 kV Looping Project	Jun-25
Tesla 230 kV Bus Series Reactor	Aug-23
Lockeford-Lodi Area 230 kV Development	Jul-27
Kasson – Kasson Junction 1 115 kV Line Section Reconductoring Project	Jun-27
Manteca #1 60 kV Line Section Reconductoring Project	Jun-27
Manteca-Ripon-Riverbank-Melones Area 115 kV Line Reconductoring Project	2028
Weber-Mormon Jct Line Section Reconductoring Project	2027
Banta 60 kV Bus Voltage Conversion	2024
Tesla 115 kV Bus Reconfiguration	2030

Stockton Area Transmission System & LCR Sub-areas

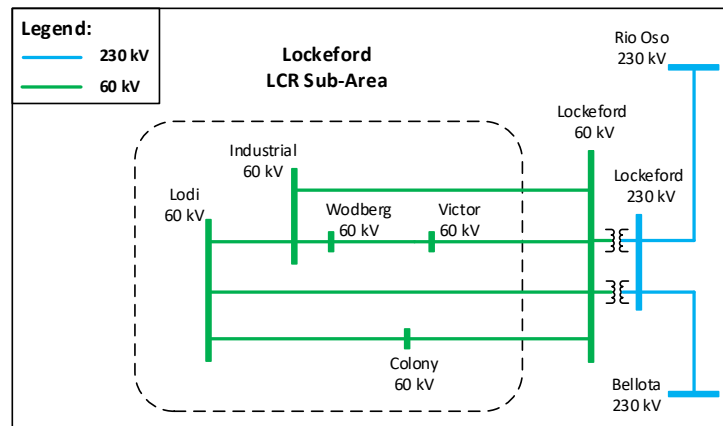
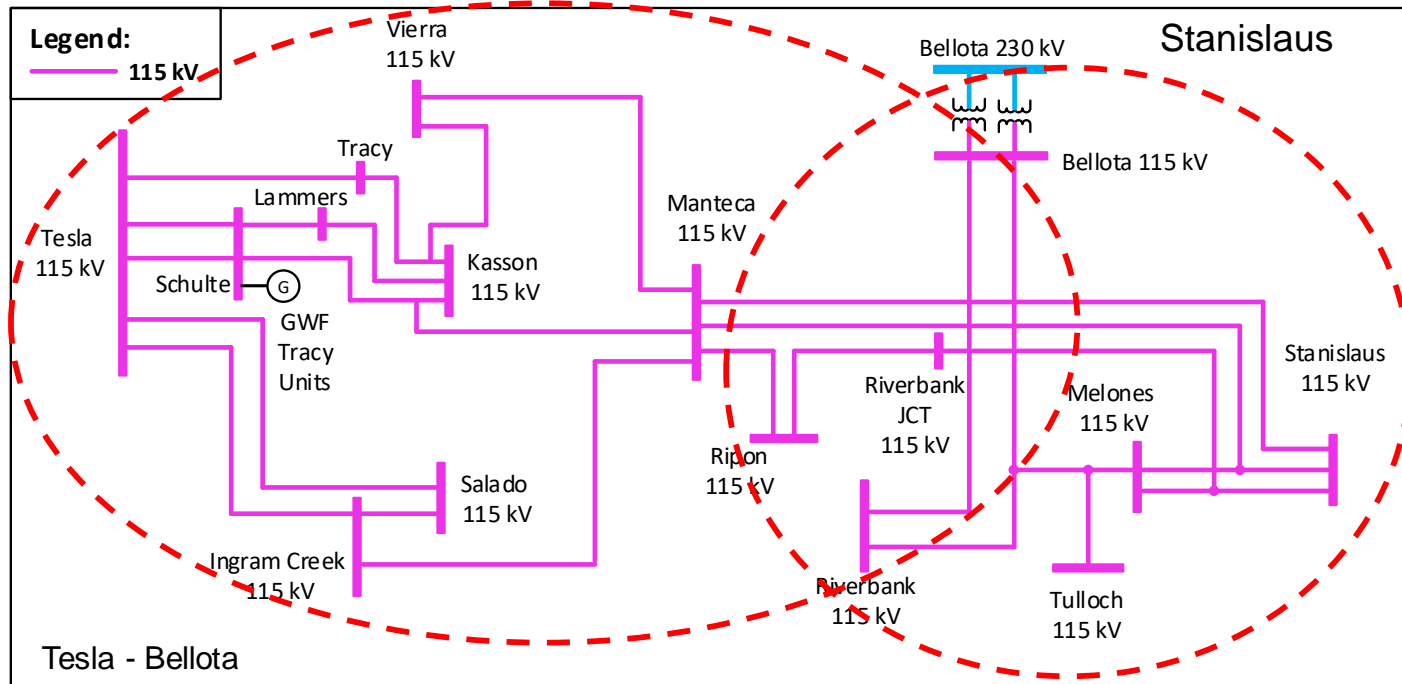

Power plant changes

- Addition
 - About 12 MW of Solar PV and BESS at Salado
 - About 132 MW of BESS at Bellota

Stockton Area Overall: Load and Resources

Load (MW)	2024	2028	Generation (MW)	2024	2028
Gross Load	1063	937	Market/Net Seller	454	500
AAEE	-5	-6	Battery	153	153
Behind the meter DG	0	0	Muni	130	106
Net Load	1058	931	QF	0	0
Transmission Losses	22	18	Solar	7	7
Pumps	0	0	Mothballed	0	0
Load + Losses + Pumps	1080	949	Total Qualifying Capacity	744	766

Lockeford Sub-Area : Requirements

Year	Category	Limiting Facility	Contingency	LCR (MW) (Deficiency)
2024	P3	Lockeford – Lodi #2 60 kV	Lockeford-Industrial 60 kV line and Lodi CT	24
2028	No LCR due to implementation of the Lockeford – Lodi 230 kV Area 230 kV Project			No requirements

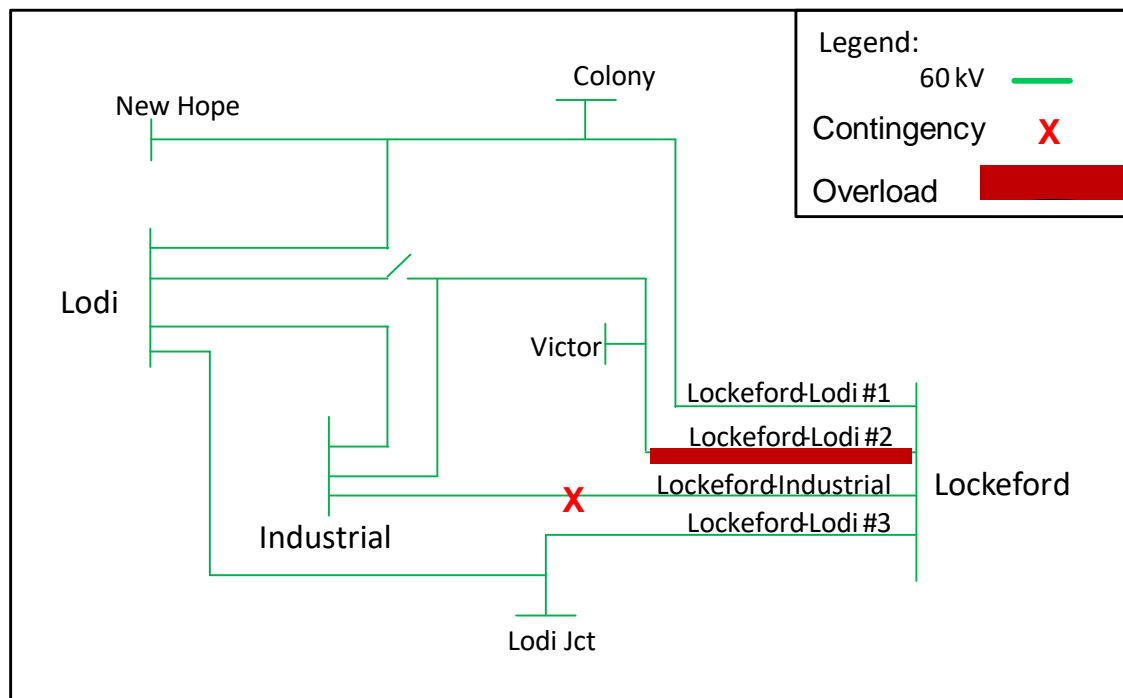

Lockeford Sub-area: Load Profiles

Stockton - Lockeford LCR Subarea:
 2024 projected pk day load profile & approx. LSC (trans + LCR Gen + ES)
 Approx storage size that can be added to this area from charging restriction
 perspective =
 24 MW and 120 MWh. Max 4-hr storage = 24 MW

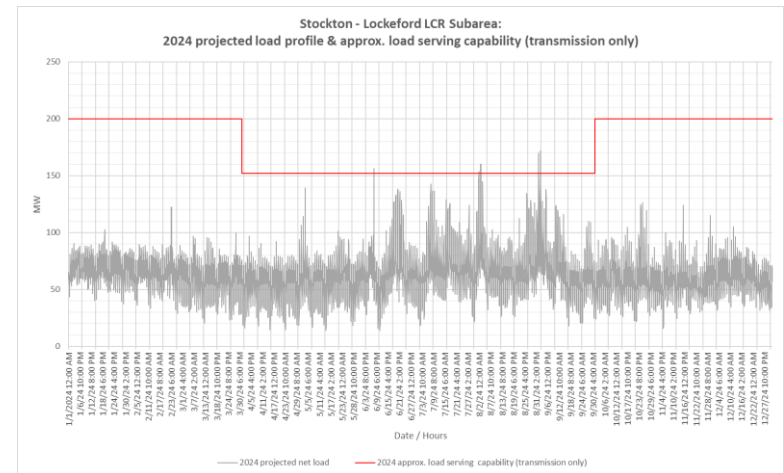
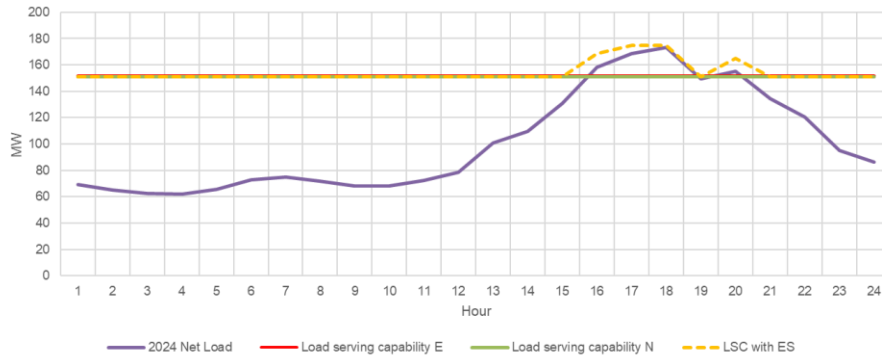

Stanislaus Sub-Area Requirements

Year	Category	Limiting Facility	Contingency	LCR (MW) (Deficiency)
2024	P3	VIERRA 115 kV – MANTECA 115 kV	Bellota-Riverbank-Melones 115 kV line and Stanislaus PH unit	177
2028	P3	VIERRA 115 kV – MANTECA 115 kV	Bellota-Riverbank-Melones 115 kV line and Stanislaus PH unit	186

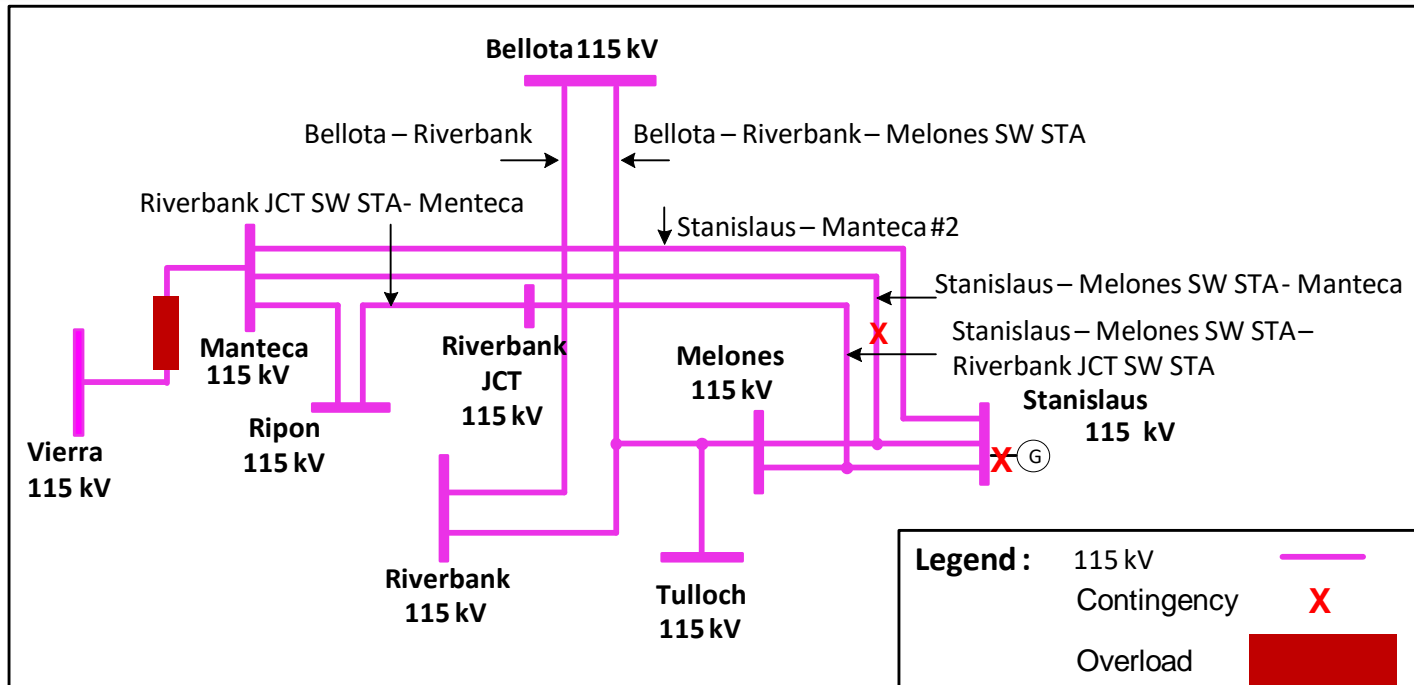

Tesla - Bellota Sub-Area Requirements

Year	Category	Limiting Facility	Contingency	LCR (MW) (Deficiency)
2024	P2-4	Melones–Riverbank-Bellota 115 kV	P2-4:A11:10:_TESLA 115KV - SECTION 2D & 1D	706 (118)
2024	P6	Tesla – Tracy 115 kV	Schulte - Lammers 115 kV Line and Schulte - Kasson - Manteca 115 kV Line	938 (554)
Total LCR Need in 2024				1274 (554)

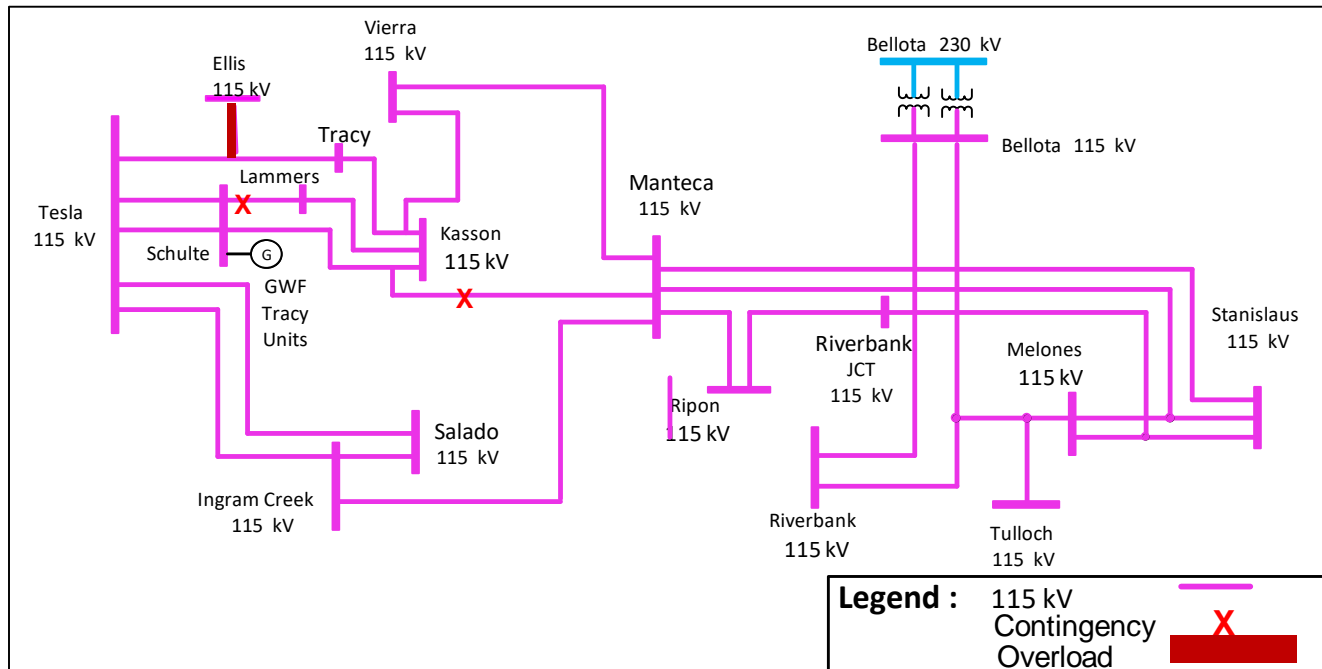

Tesla - Bellota Sub-area: Load Profiles

Stockton - Tesla-Bellota LCR Subarea:
 2024 projected pk day load profile & approx. LSC (trans + LCR Gen + ES)
 Approx storage size that can be added to this area from charging restriction
 perspective =
 385 MW and 1945 MWh. Max 4-hr storage = 330 MW

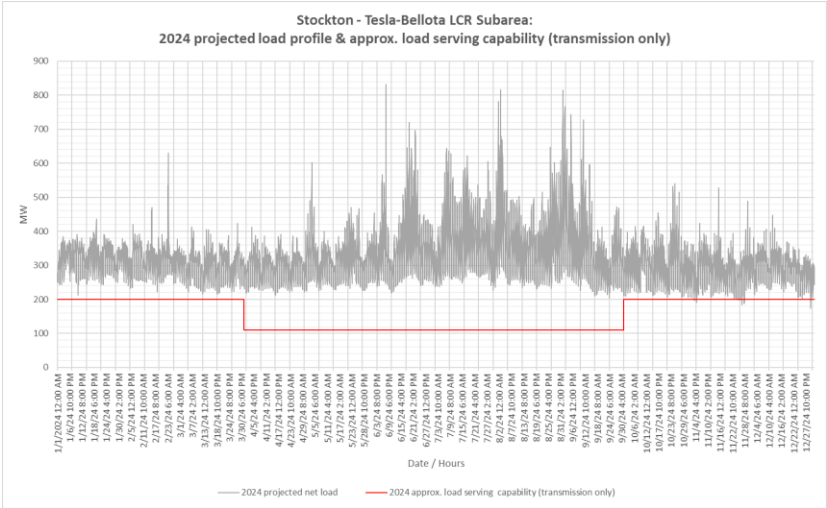
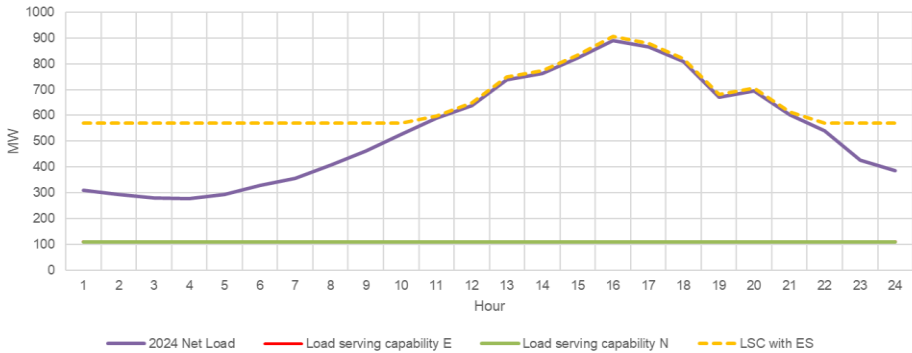

Tesla - Bellota Sub-Area Requirements

Year	Category	Limiting Facility	Contingency	LCR (MW) (Deficiency)
2028	P2-4	Melones–Riverbank-Bellota 115 kV	P2-4:A11:10:_TESLA 115KV - SECTION 2D & 1D	735 (101)
2028	P6	Tesla – Tracy 115 kV	Schulte - Lammers 115 kV Line and Schulte - Kasson - Manteca 115 kV Line	718 (288)
Total LCR Need in 2028				1054 (288)

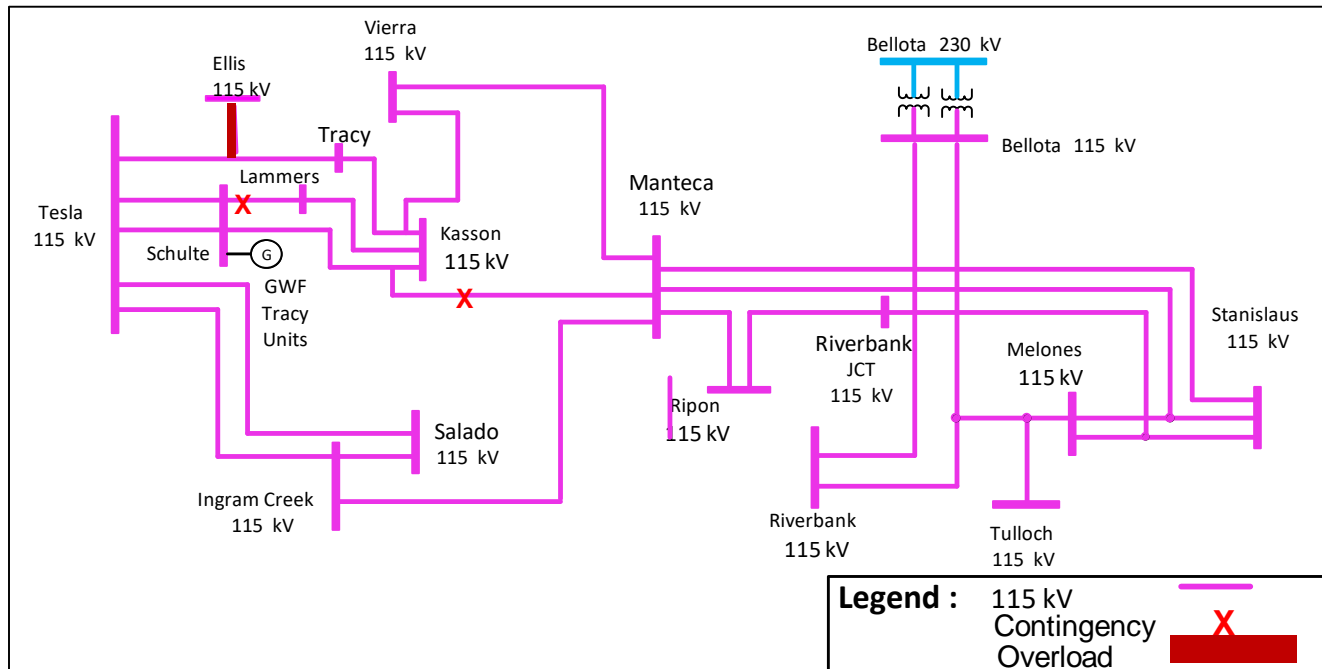

Tesla - Bellota Sub-area: Load Profiles

Stockton - Tesla-Bellota LCR Subarea:
 2028 projected pk day load profile & approx. LSC (trans + LCR Gen + ES)
 Approx storage size that can be added to this area from charging restriction
 perspective =
 330 MW and 2066 MWh. Max 4-hr storage = 190 MW

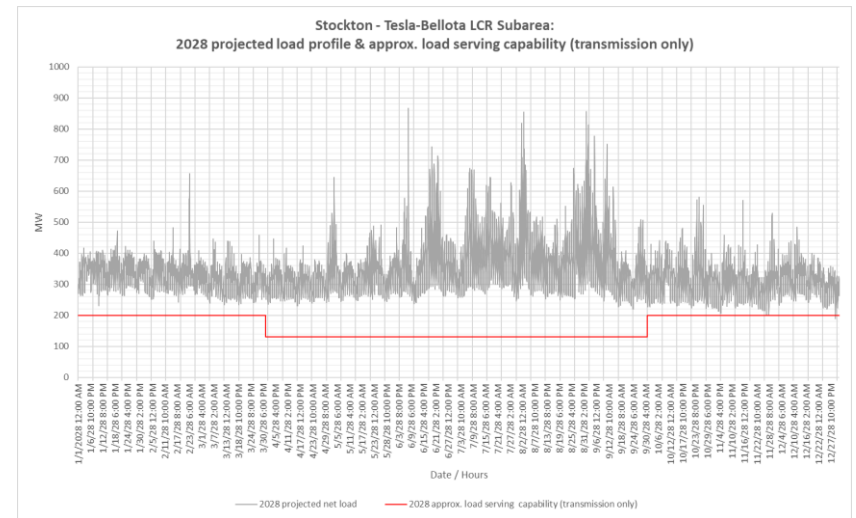
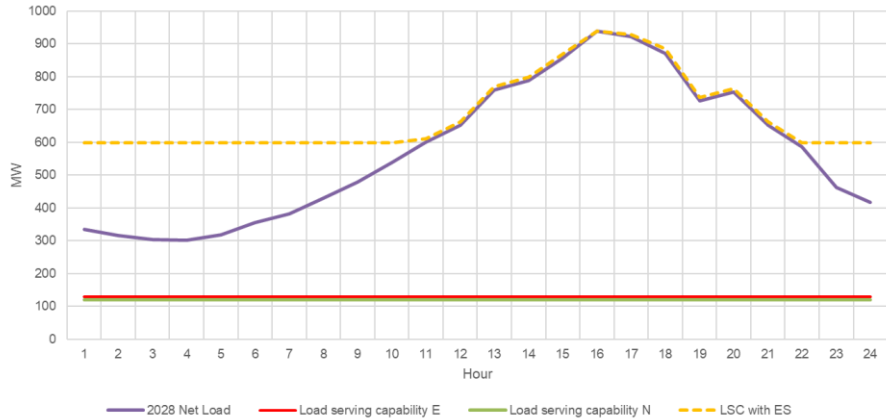

Changes from 2023 to 2024

Sub-area	2023		2024	
	Load	LCR	Load	LCR
Lockeford	181	27 (3)	175	24
Stanislaus	N/A	155	N/A	177
Tesla - Bellota	909	965 (410)	888	1274 (554)
Total	1090	992 (413)	1063	1298 (554)

- The load forecast has slightly decreased and the LCR need has increased mainly due to new resources available in the area.
- N/A=Flow-through area. No defined load pocket or not an LCR sub-area anymore

Changes from 2027 to 2028

Sub-area	2027		2028	
	Load	LCR	Load	LCR
Lockeford	196	0	N/A	N/A
Stanislaus	N/A	177	N/A	185
Tesla - Bellota	951	953 (404)	931	1054 (288)
Total	1147	953 (404)	931	1054 (288)

- There is no a LCR requirement in Lockeford sub-area for 2028 after the implementation of the Lockeford – Lodi 230 kV Area 230 kV Project
- The Vierra Loop-in project and Tesla 115 kV Bus upgrade will address some of the LCR requirements in Tesla- Bellota Area
- The load forecast has slightly decreased and the LCR need has increased mainly due to new resources available in the area.
- N/A=Flow-through area. No defined load pocket or not an LCR sub-area anymore

Stockton Area Total LCR Need

Study Year	Existing Generation Capacity Needed (MW)	NQC Deficiency (MW)	Total MW Need
2024	744	554	1298
2028	766	288	1054

* = Deficiency numbers – subject to change after finalization of NQC totals