



2022 and 2026 Draft LCR Study Results Greater Fresno Area

Vera Hart

Senior Regional Transmission Engineer

Emily Hughes

Regional Transmission Engineer

Stakeholder Call

March 11, 2021

Greater Fresno Area

Electrical Boundaries and LCR Sub-Areas

Electrical Boundaries:

- Gates – Mustang #1 230 kV line
- Gates – Mustang #2 230 kV line
- Panoche – Tranquility #1 230 kV line
- Panoche – Tranquility #2 230 kV line
- Warnerville – Wilson 230 kV line
- Melones – Wilson 230 kV line
- Panoche 230/115 kV transformer #1
- Panoche 230/115 kV transformer #2
- Smyrna – Alpaugh – Corcoran 115 kV line
- Los Banos #3 230/70 kV transformer
- Los Banos #4 230/70 kV transformer
- San Miguel – Coalinga #1 70 kV line
- Gates 230/70 kV transformer #5

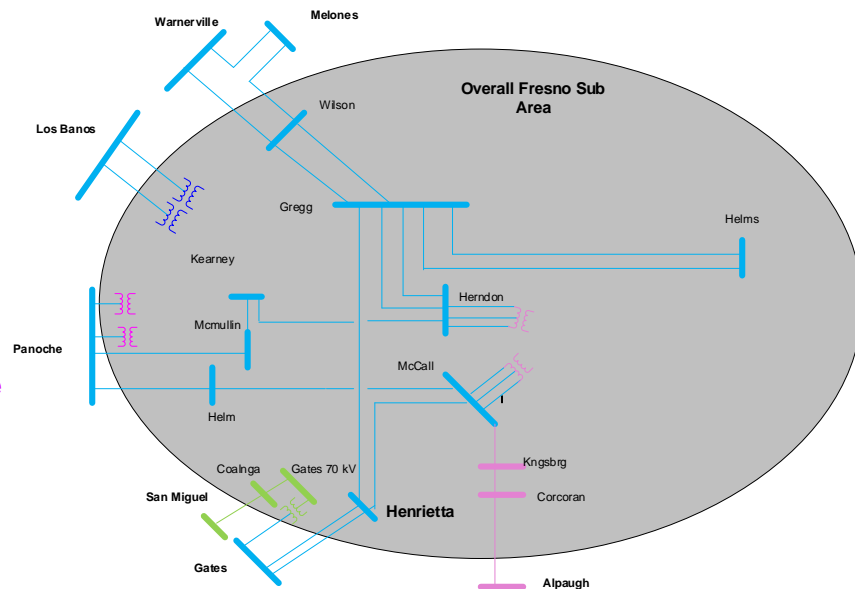

New major transmission projects

Project Name	Expected ISD
Oro Loma 70 kV Area Reinforcement	25-Apr
Reedley 70 kV Reinforcement (Renamed to Reedley 70 kV Area Reinforcement Projects Include Battery at Dinuba)	21-May
Wilson 115 kV Area Reinforcement	28-May
Wilson-Le Grand 115 kV line Reconductoring	21-Apr
Panoche – Oro Loma 115 kV Line Reconductoring	2023
Northern Fresno 115 kV Area Reinforcement	20-May
Bellota-Warnerville 230kV line Reconductoring	24-Mar
Herndon-Bullard 230kV Reconductoring Project	21-Jan
Gregg-Herndon #2 230 kV Line Circuit Breaker Upgrade	20-Jan
Wilson-Oro Loma 115 kV Line Reconductoring	2026

Power plant changes

Resource Additions:

- None

Resource Retirements:

- None

Hanford Sub-area: Load and Resources

Load (MW)	2022	2026	Generation (MW)	2022	2026
Gross Load	203	210	Market	125	125
AAEE	-1	-3	Solar	25	25
Behind the meter DG	0	0	MUNI	0	0
Net Load	202	207	QF	0	0
Transmission Losses	7	7			
Pumps	0	0	Total Qualifying Capacity	150	150
Load + Losses + Pumps	209	214			

Hanford Sub-Area Requirements

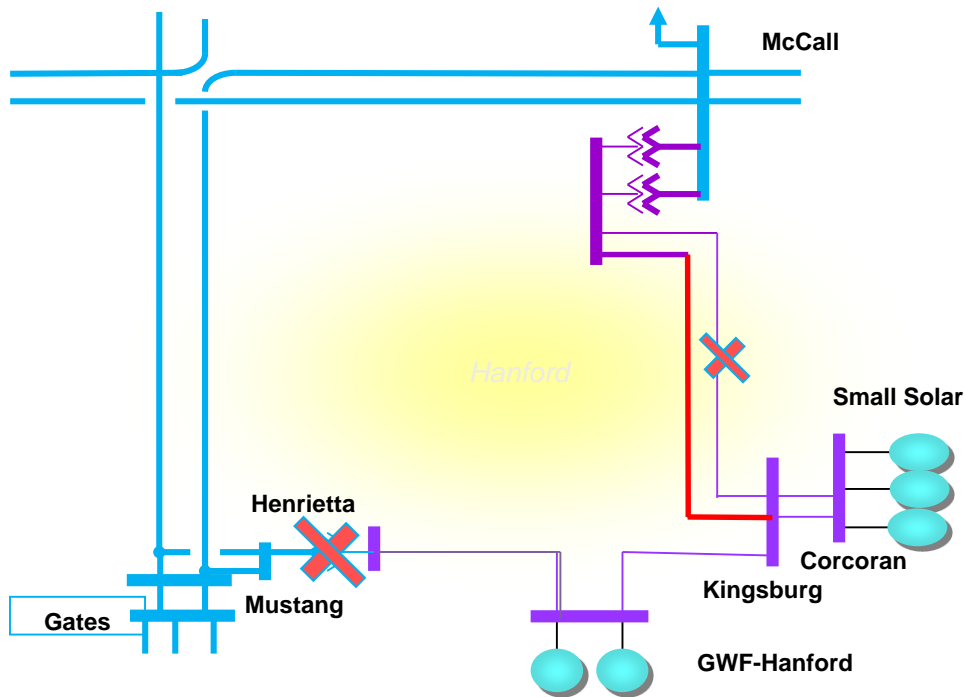

Limit	Category	Limiting Facility	Contingency	2022 LCR (MW)	2026 LCR (MW)
First Limit	P6	McCall-Kingsburg #2 115kV Line	McCall-Kingsburg #1 115kV line and Henrietta 230/115kV TB#3	70	76

Hanford Sub-area: Load Profiles

GFA - Hanford LCR Subarea:

2022 projected pk day load profile & approx. LSC (trans + LCR Gen + ES)

Approx storage size that can be added to this area from charging restriction perspective = 70 MWh and 382 MWh. Max 4-hr storage = 65 MW

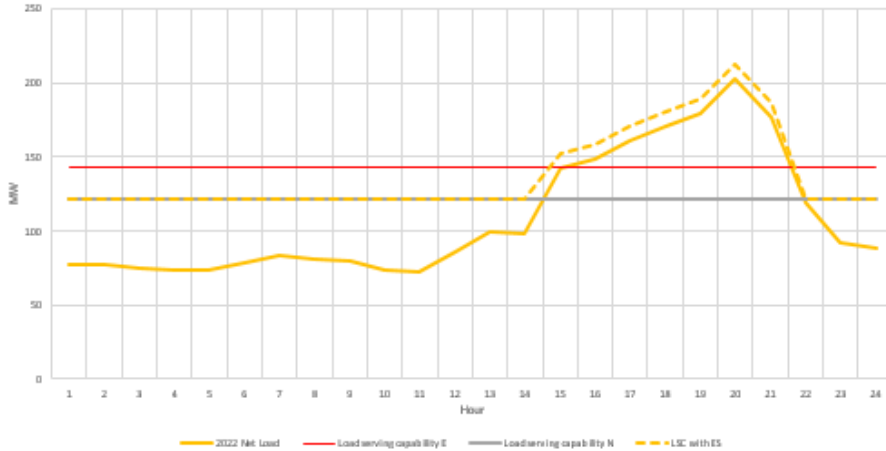

GFA - Hanford LCR Subarea:

2022 projected load profile & approx. load serving capability (transmission only)

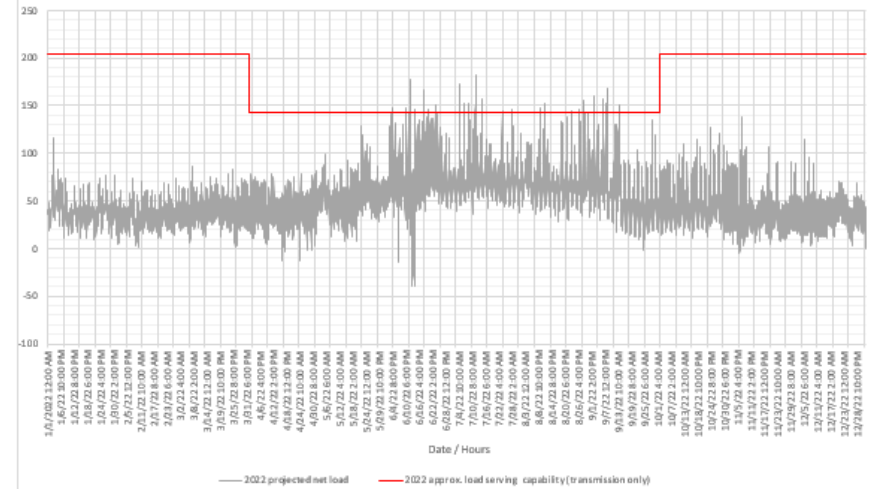

GFA - Hanford LCR Subarea:

2026 projected pk day load profile & approx. LSC (trans + LCR Gen + ES)

Approx storage size that can be added to this area from charging restriction perspective = 76 MWh and 404 MWh. Max 4-hr storage = 65 MW

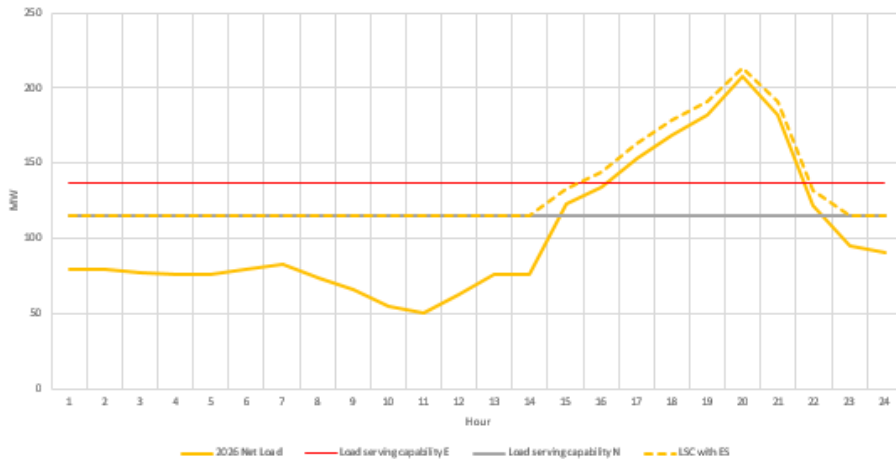

GFA - Hanford LCR Subarea:

2026 projected load profile & approx. load serving capability (transmission only)

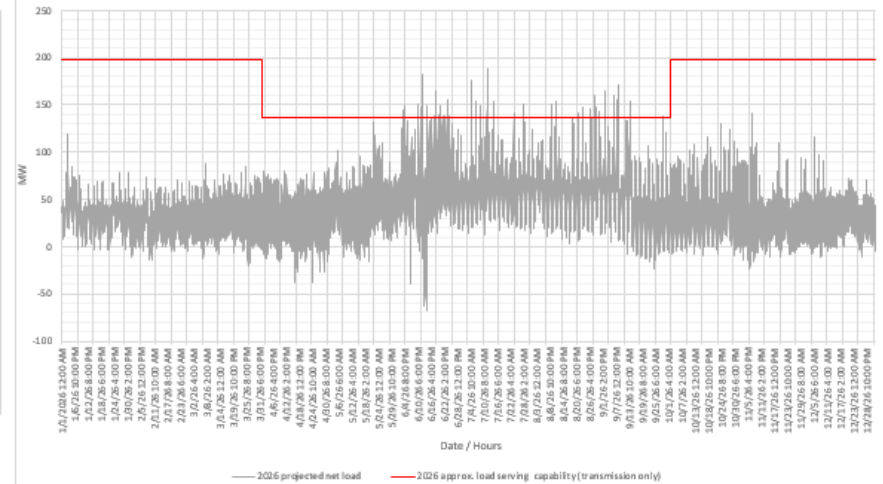

Coalinga Sub-area: Load and Resources

Load (MW)	2022	2026	Generation (MW)	2022	2026
Gross Load	117	120	Market	0	0
AAEE	-1	-1	Solar	13	13
Behind the meter DG	0	0	MUNI	0	0
Net Load	116	119	QF	3	3
Transmission Losses	2	2	Mothballed	0	0
Pumps	0	0	Total Qualifying Capacity	16	16
Load + Losses + Pumps	118	121			

Coalinga Sub-Area Requirements

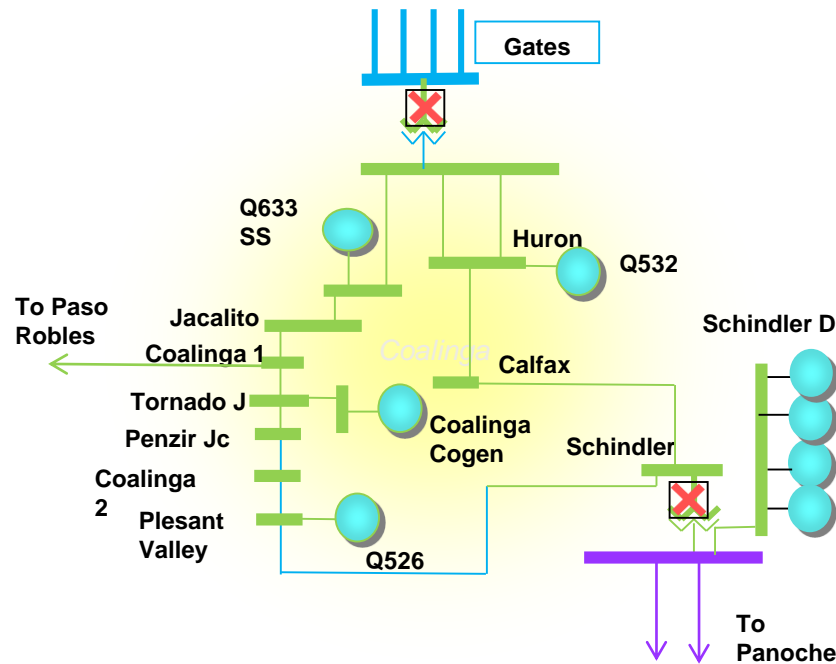

Limit	Category	Limiting Facility	Contingency	2022 LCR (MW)	2026 LCR (MW)
First Limit	P6	Overload on San-Miguel-Coalinga 70kV Line and Voltage Instability	T-1/T-1: Gates 230/70kV TB #5 and Schindler 115/70 kV TB#1	95 (92 Peak; 79 NQC)	96 (93 Peak, 80 NQC)

Coalinga Sub-area: Load Profiles

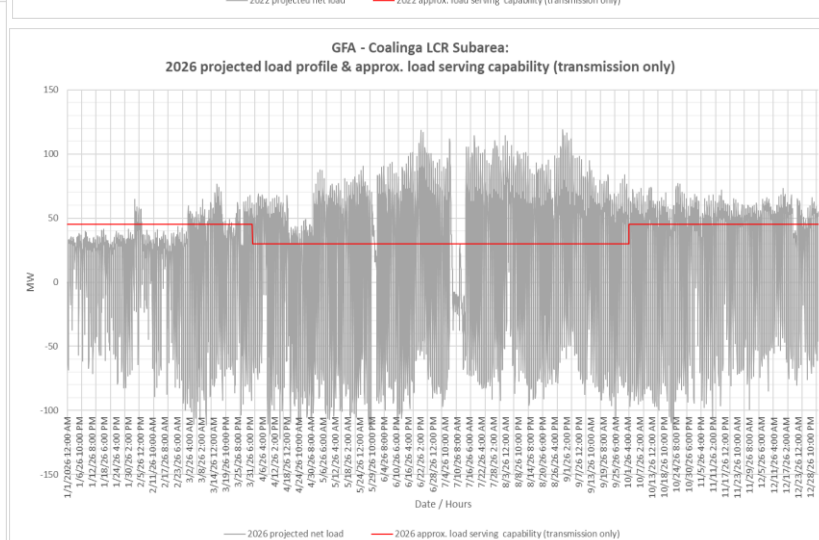
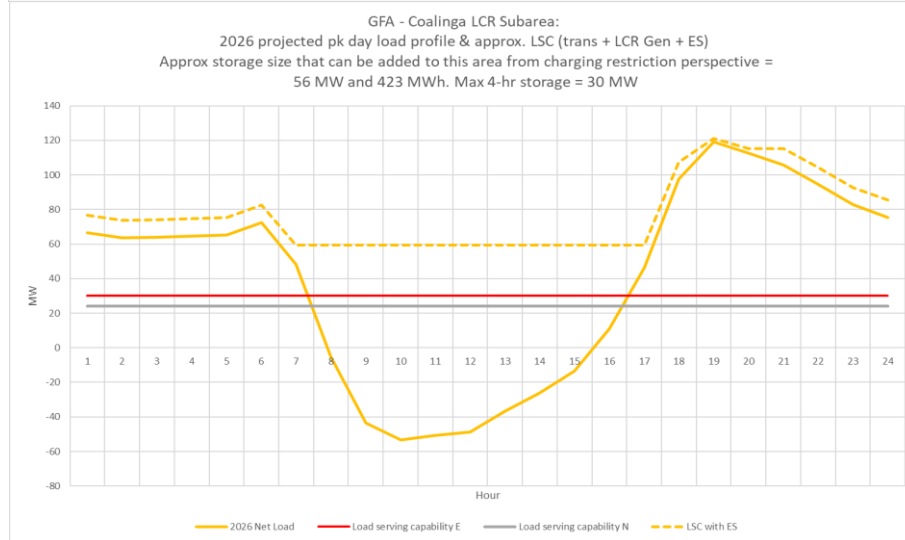
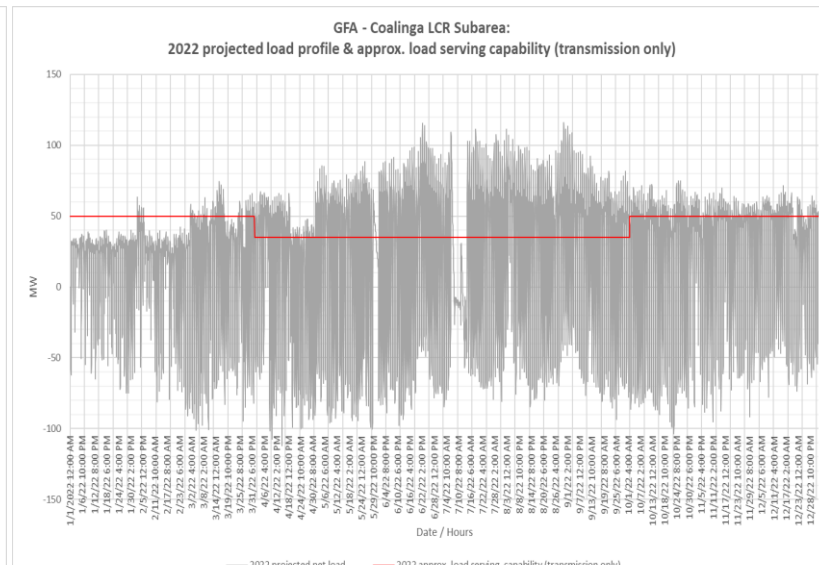
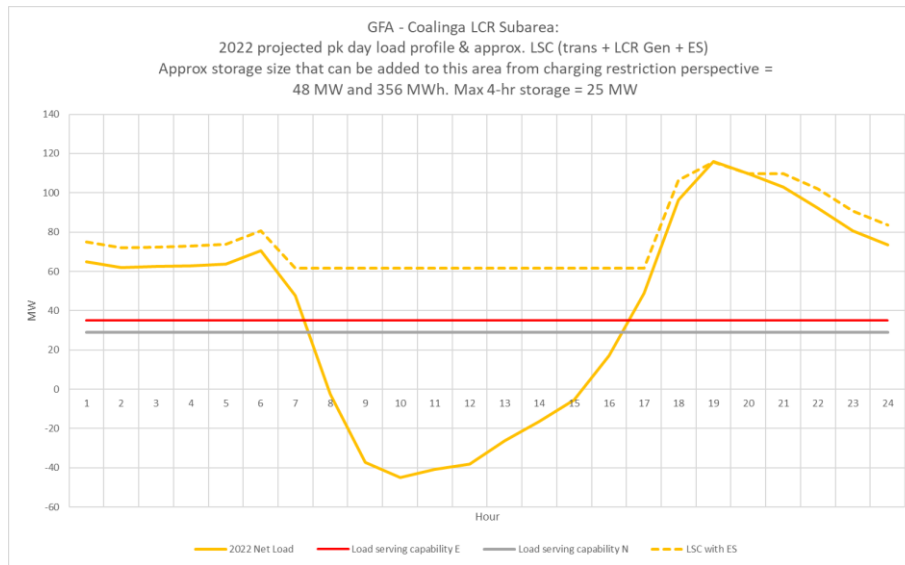

Borden Sub-area: Load and Resources

Load (MW)	2022	2026	Generation (MW)	2022	2026
Gross Load	146	152	Market, Net Seller	33	33
AAEE	-1	-2	Solar	13	13
Behind the meter DG	0	0	MUNI	0	0
Net Load	145	150	QF	0	0
Transmission Losses	4	4	Mothballed	0	0
Pumps	0	0	Total Qualifying Capacity	46	46
Load + Losses + Pumps	149	154			

Borden Sub-Area Requirements

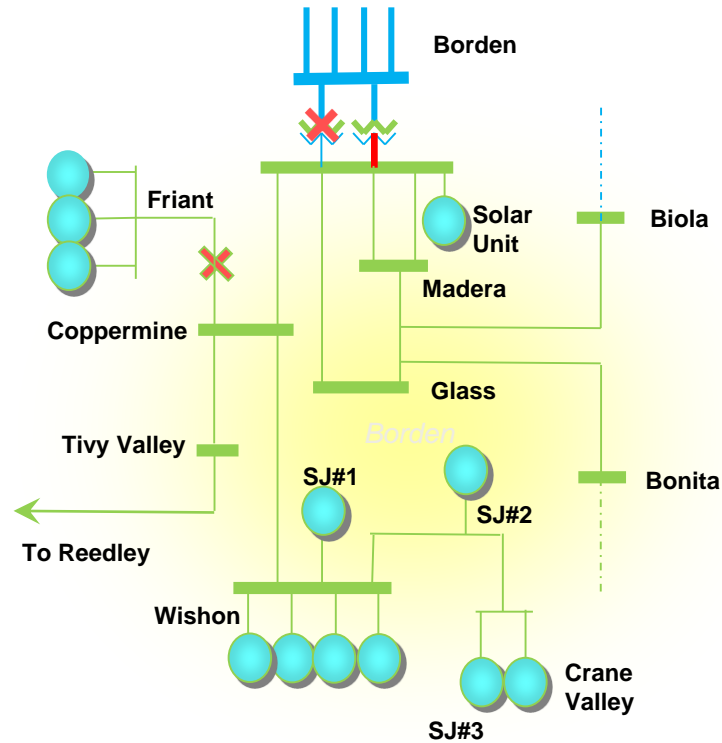

Limit	Category	Limiting Facility	Contingency	2022 LCR (MW)	2026 LCR (MW)
First Limit	P6	Borden 230/70 kV TB # 1	Friant - Coppermine 70 kV Line and Borden 230/70 kV TB # 4	35 (2 Peak)	38 (5 Peak)

Borden Sub-area: Load Profiles

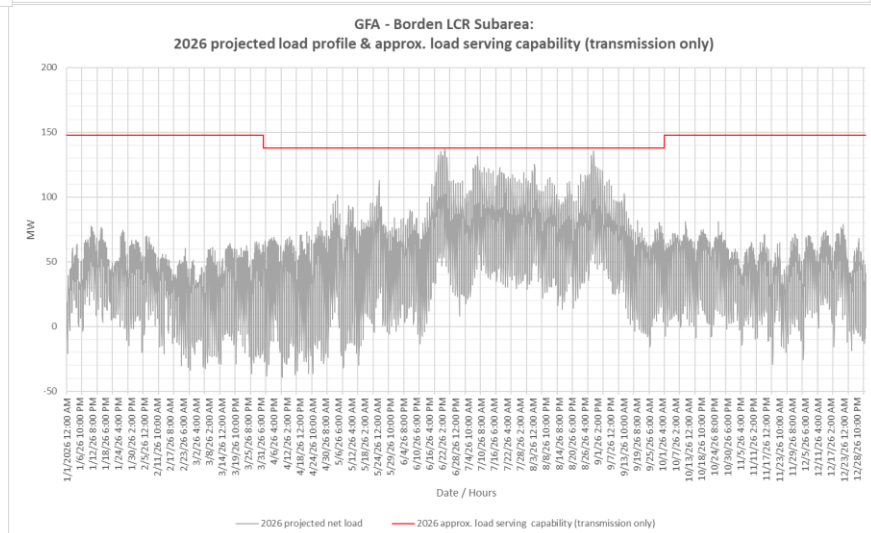
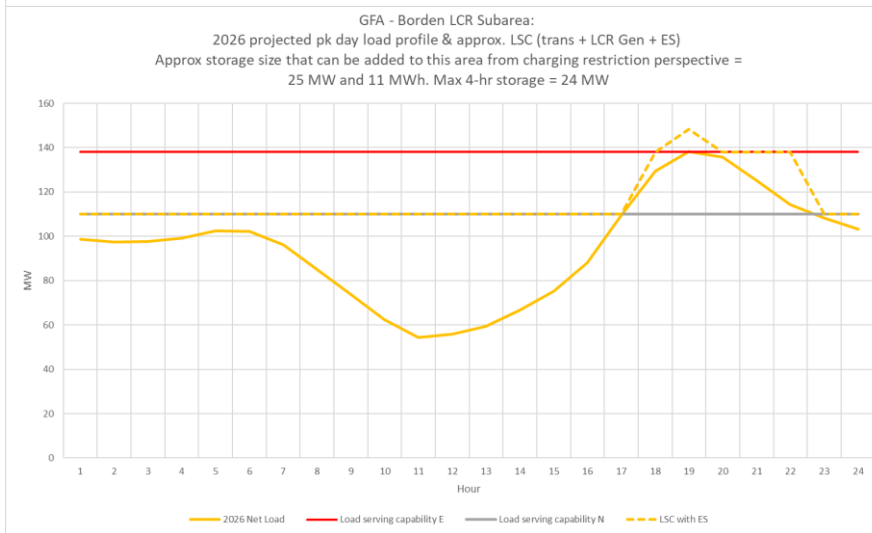
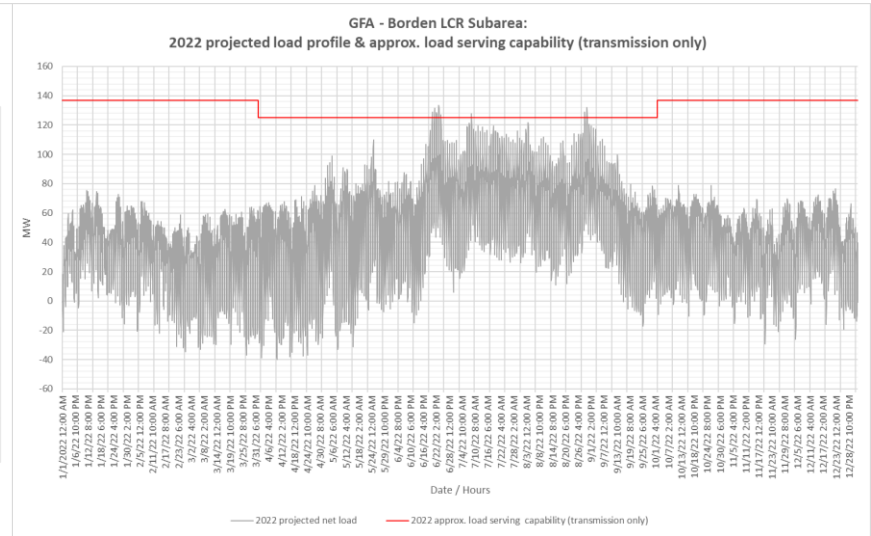
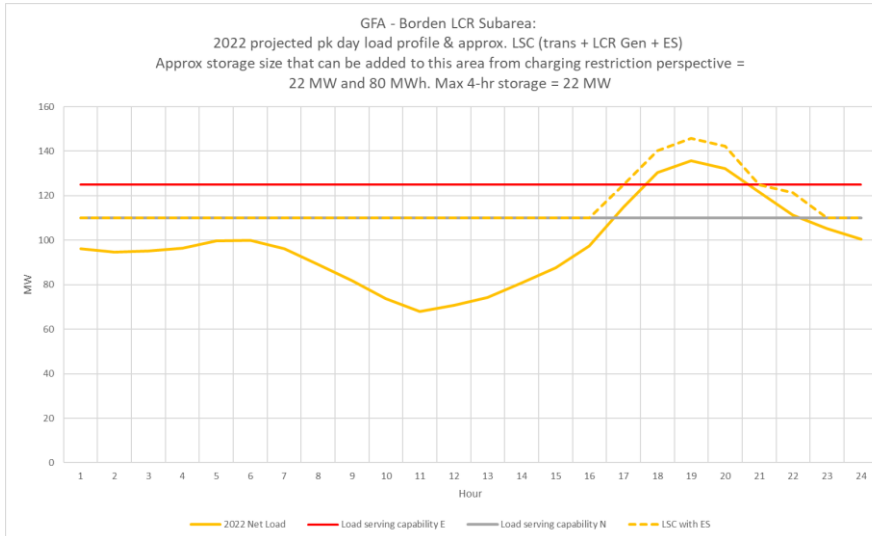

Reedley Sub-area: Load and Resources

Load (MW)	2022	2026	Generation (MW)	2022	2026
Gross Load	228	236	Market	51	51
AAEE	-2	-3	Solar	0	0
Behind the meter DG	0	0	MUNI	0	0
Net Load	226	233	QF	0	0
Transmission Losses	7	19			
Pumps	0	0	Total Qualifying Capacity	51	51
Load + Losses + Pumps	233	252			

Reedley Sub-Area Requirements

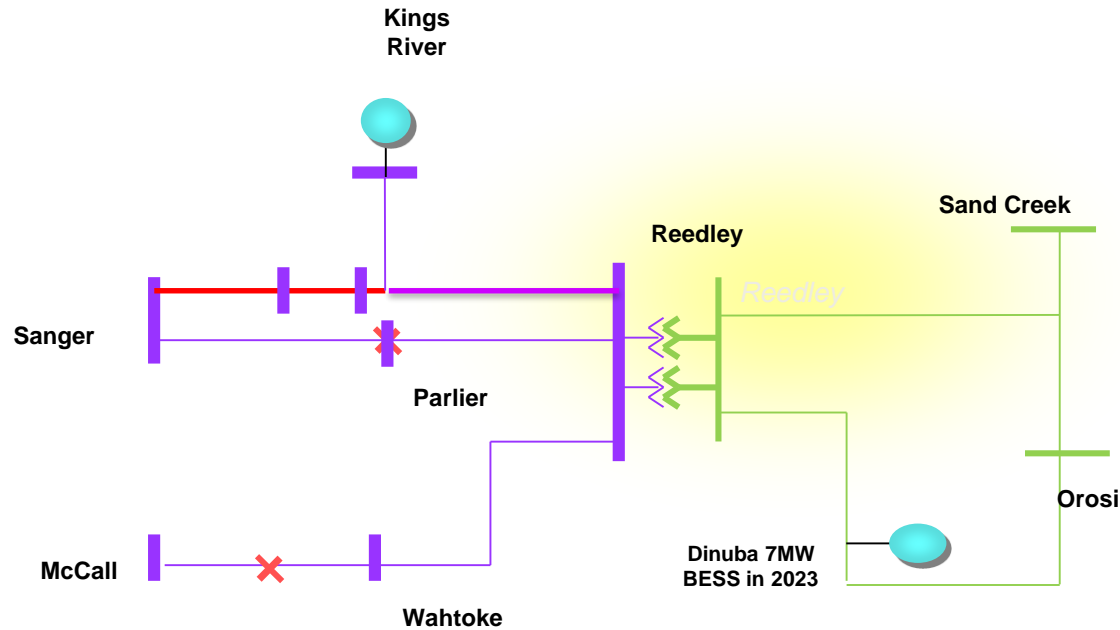

Limit	Category	Limiting Facility	Contingency	2022 LCR (MW)	2026 LCR (MW)
First Limit	P6	Kings River-Sanger-Reedley 115kV line with Wahtoke load online	McCall-Reedley 115kV Line & Sanger-Reedley 115kV line	144 (93)	154 (103)

Reedley Sub-area: Load Profiles

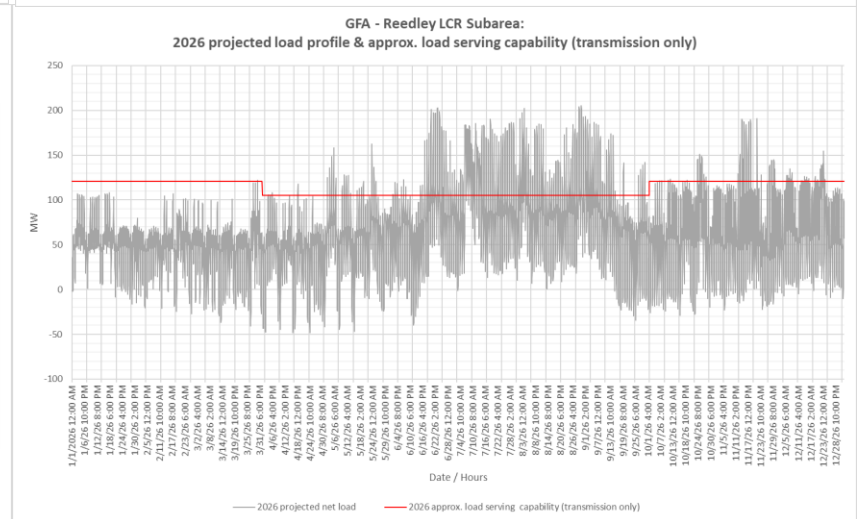
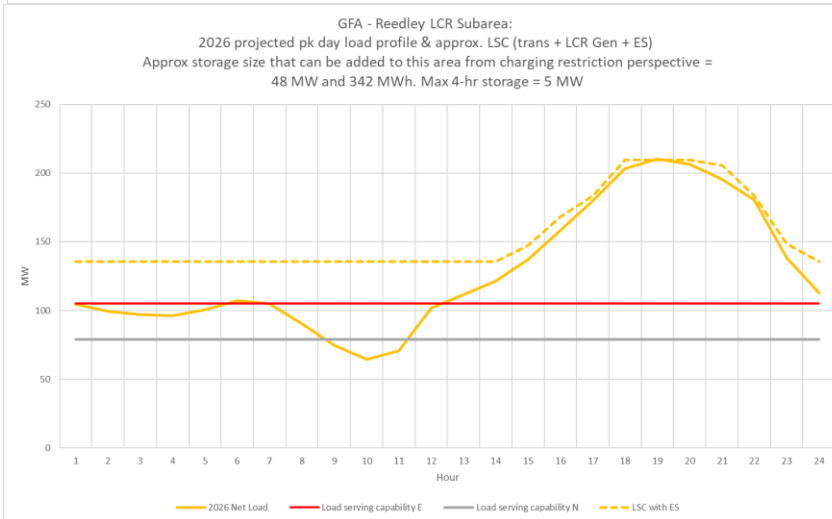
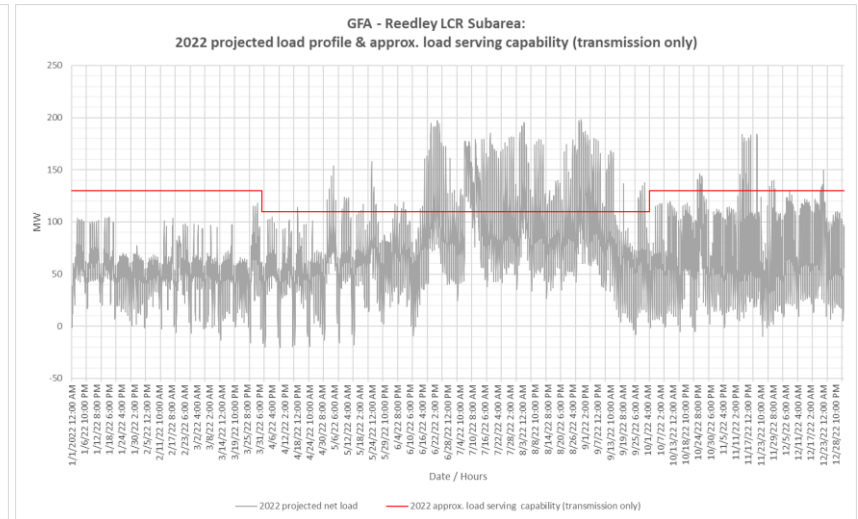
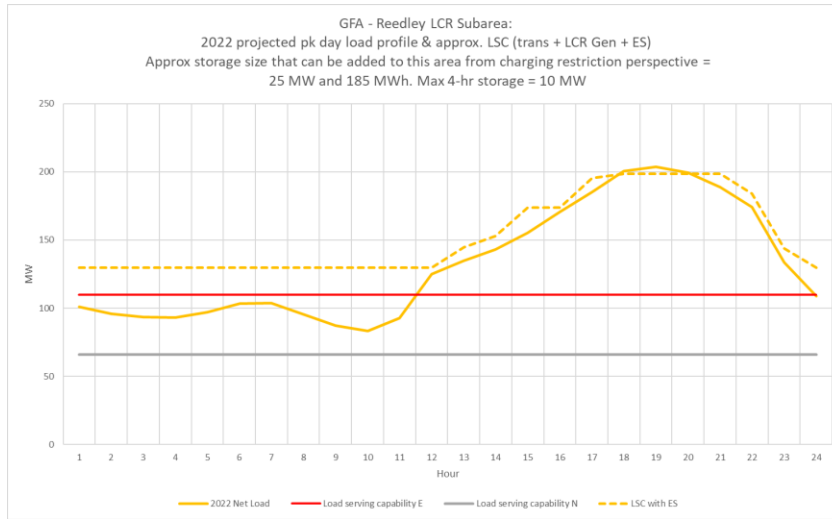

Panoche 115-70 kV Sub-area: Load and Resources

Load (MW)	2022	2026	Generation (MW)	2022	2026
Gross Load	463	481	Market/Net Seller	282	282
AAEE	-3	-5	Solar	89	89
Behind the meter DG	-1	-1	MUNI	100	100
Net Load	459	475	QF	3	3
Transmission Losses	16	16			
Pumps	0	0	Total Qualifying Capacity	474	474
Load + Losses + Pumps	475	491			

Panoche 115-70 kV Sub-Area Requirements

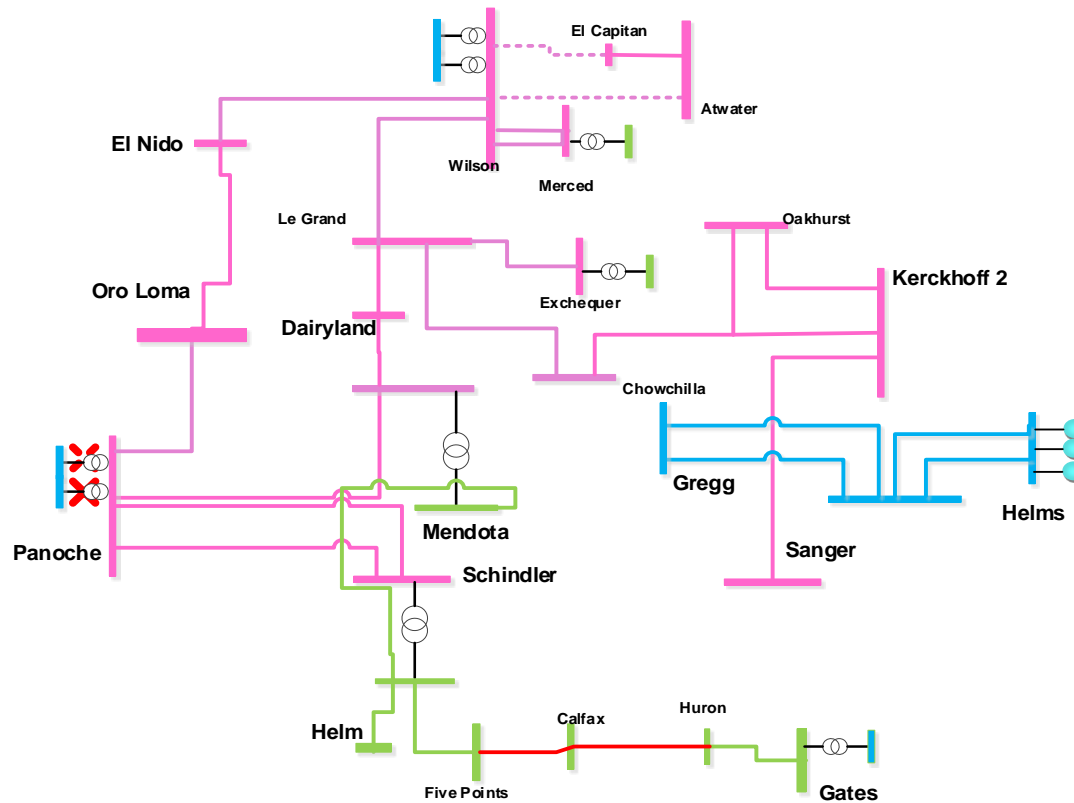

Limit	Category	Limiting Facility	Contingency	2022 LCR (MW)	2026 LCR (MW)
First Limit	P6	Five Points-Huron-Gates 70kV line	Panoche 230/115kV TB #2 and Panoche 230/115kV TB #4	320	378



Panoche Sub-area: Load Profiles

GFA - Panoche LCR Subarea:
 2022 projected pk day load profile & approx. LSC (trans + LCR Gen + ES)
 Approx storage size that can be added to this area from charging restriction perspective =
 85 MW and 422 MWh. Max 4-hr storage = 85 MW

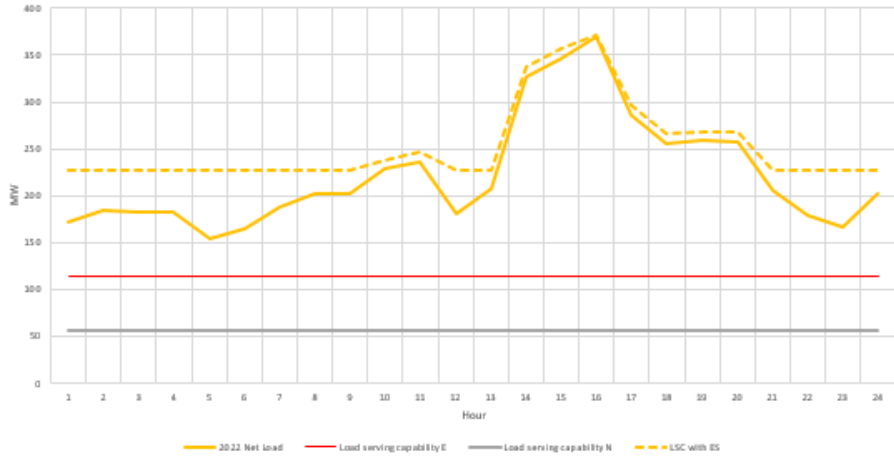

GFA - Panoche LCR Subarea:
 2022 projected load profile & approx. load serving capability (transmission only)

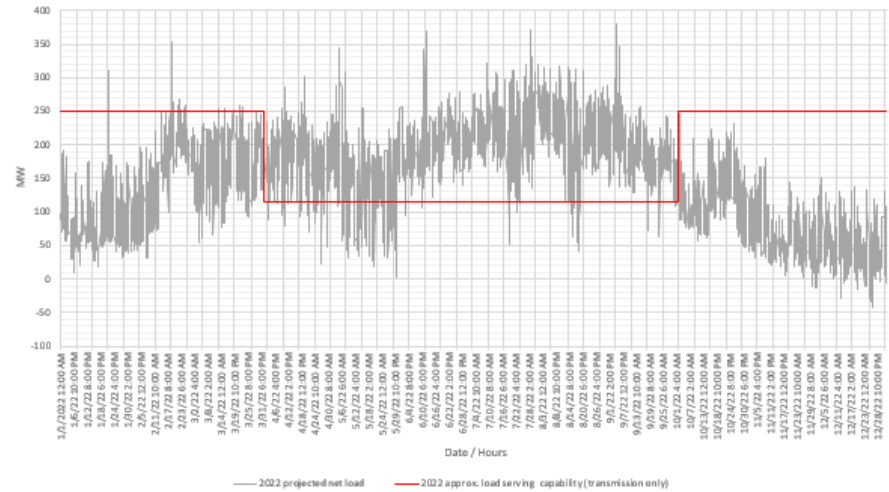

GFA - Panoche LCR Subarea:
 2026 projected pk day load profile & approx. LSC (trans + LCR Gen + ES)
 Approx storage size that can be added to this area from charging restriction perspective =
 188 MW and 491 MWh. Max 4-hr storage = 241 MW

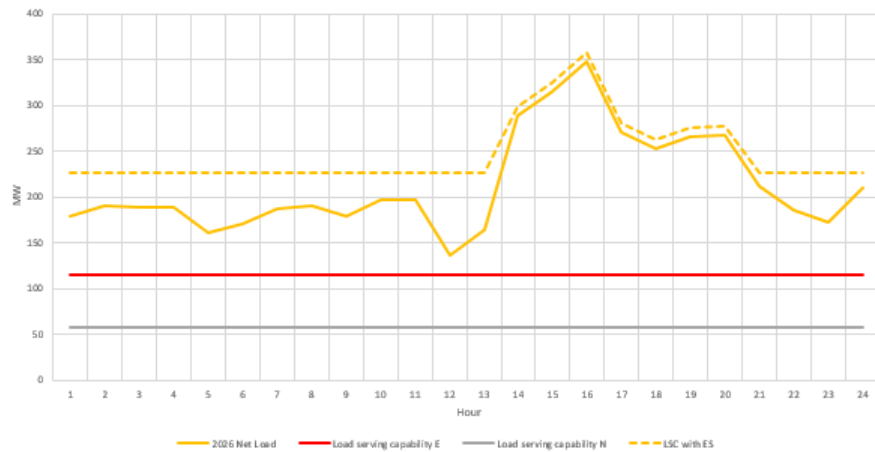

GFA - Panoche LCR Subarea:
 2026 projected load profile & approx. load serving capability (transmission only)

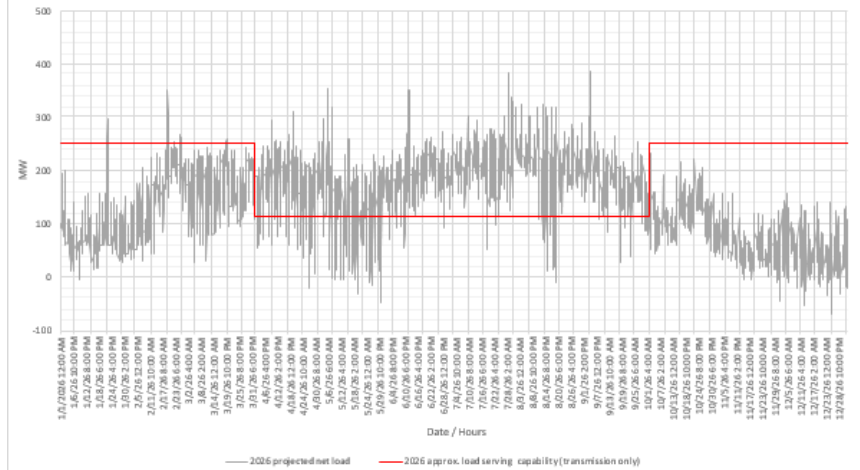

Wilson 115 kV Sub-area: Load and Resources

Load (MW)	2022	2026	Generation (MW)	2022	2026
Gross Load	NA – Flow through area.		Market/ Net Seller / Battery	260	260
AAEE			Solar	100	100
Behind the meter DG			Wind	0	0
Net Load			Muni	54	54
Transmission Losses			QF	0	0
Pumps			Future preferred resource and energy storage	0	0
Load + Losses + Pumps			Total Qualifying Capacity	414	414

Wilson 115 KV Sub-Area Requirements

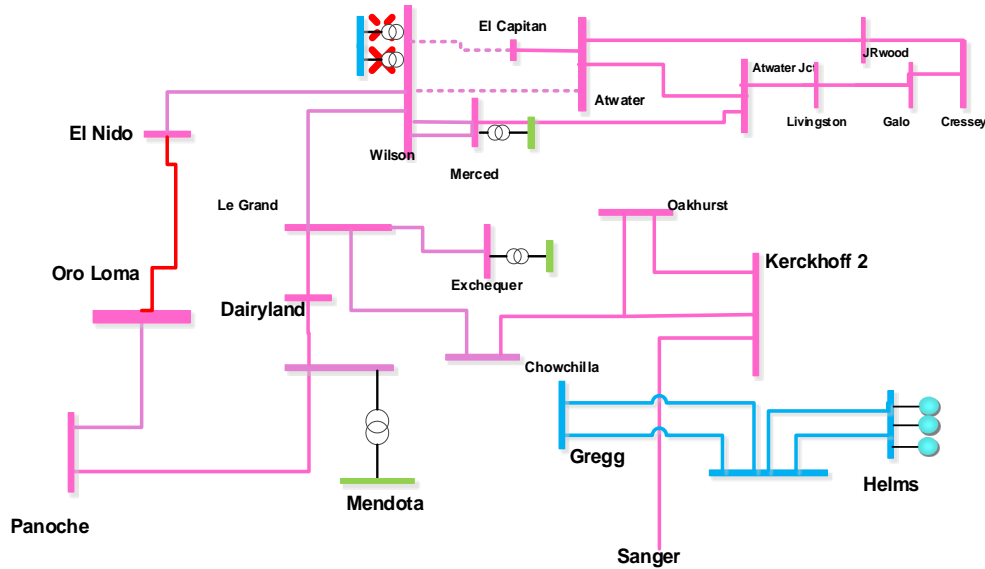

Limit	Category	2022 Limiting Facility	2026 Limiting Facility	Contingency	2022 LCR (MW)	2026 LCR (MW)
First Limit	P6	Panoche - Oro Loma 115 kV Line (Panoche - Hammonds 115 kV)	El Nido – Oro Loma 115 kV Line	Wilson 230/115kV TB #1 and Wilson 230/115kV TB #2	620 (306 Peak, 206 NQC)	403 (89 Peak)

Herndon Sub-area: Load and Resources

Load (MW)	2022	2026	Generation (MW)	2022	2026
Gross Load	1576	1653	Market	997	997
AAEE	-11	-21	Solar	63	63
Behind the meter DG	0	0	MUNI	98	98
Net Load	1565	1631	QF	1	1
Transmission Losses	35	37			
Pumps	0	0	Total Qualifying Capacity	1159	1159
Load + Losses + Pumps	1600	1669			

Herndon Sub-Area Requirements

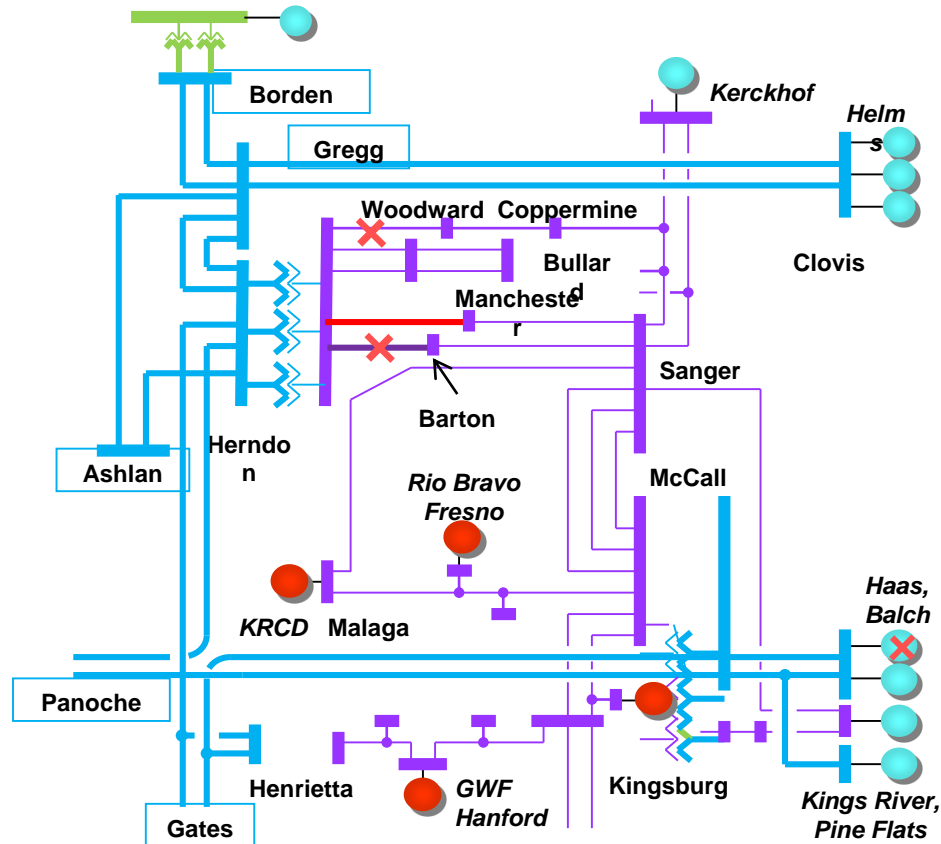

Limit	Category	Limiting Facility	Contingency	2022 LCR (MW)	2026 LCR (MW)
First limit	P6	Herndon-Manchester 115 kV line	Herndon-Woodward 115 kV line and Herndon-Barton 115 kV line	522	526

Herndon Sub-area: Load Profiles

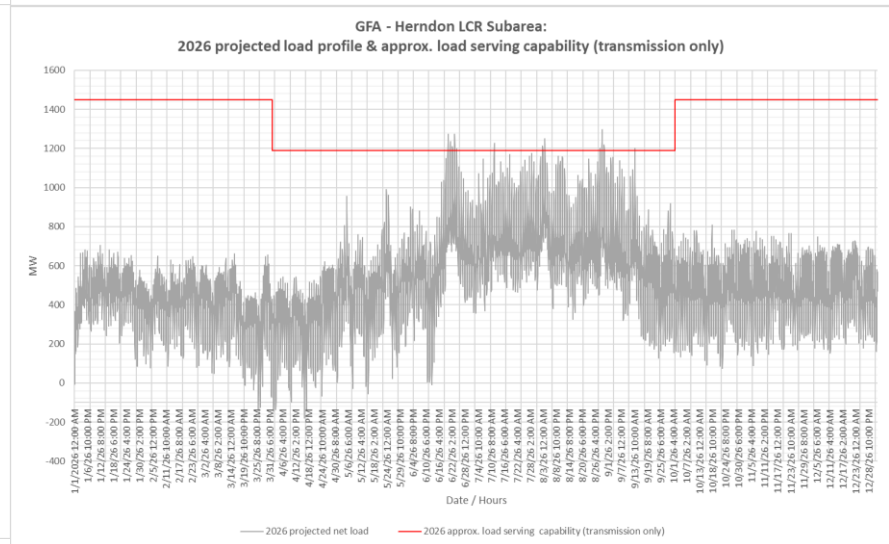
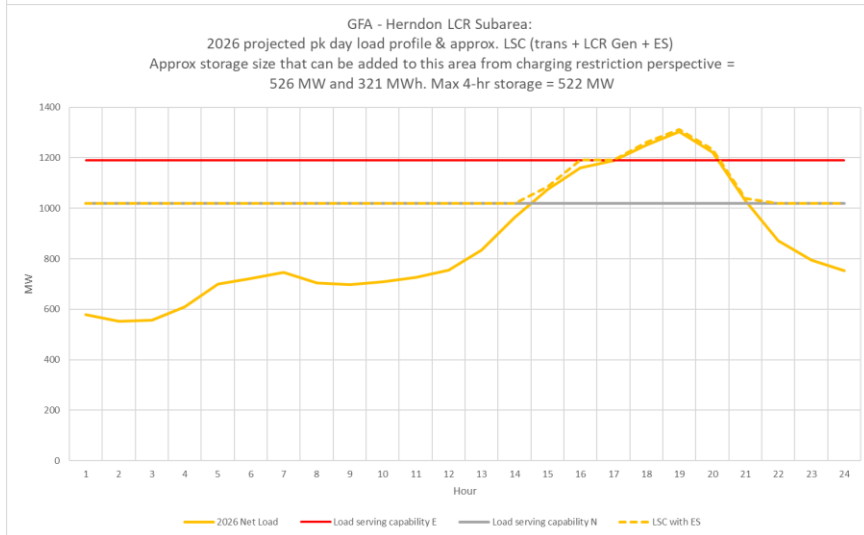
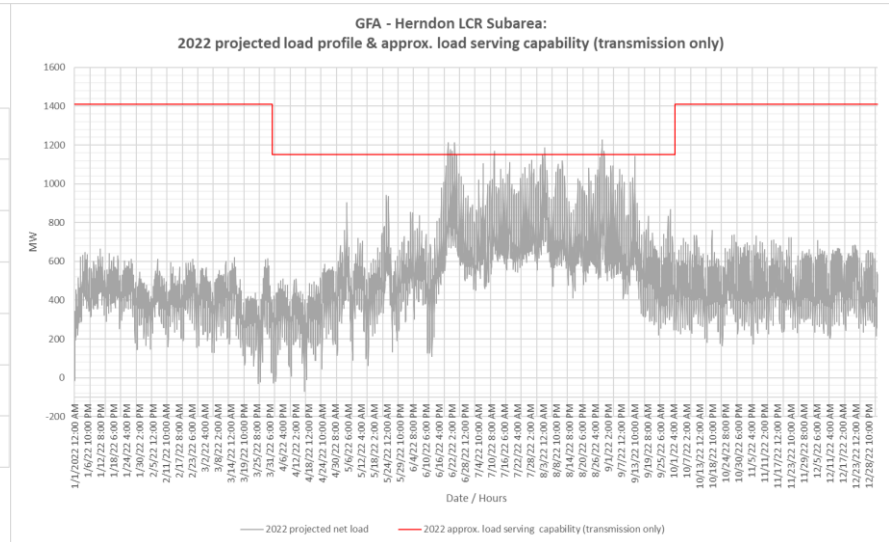
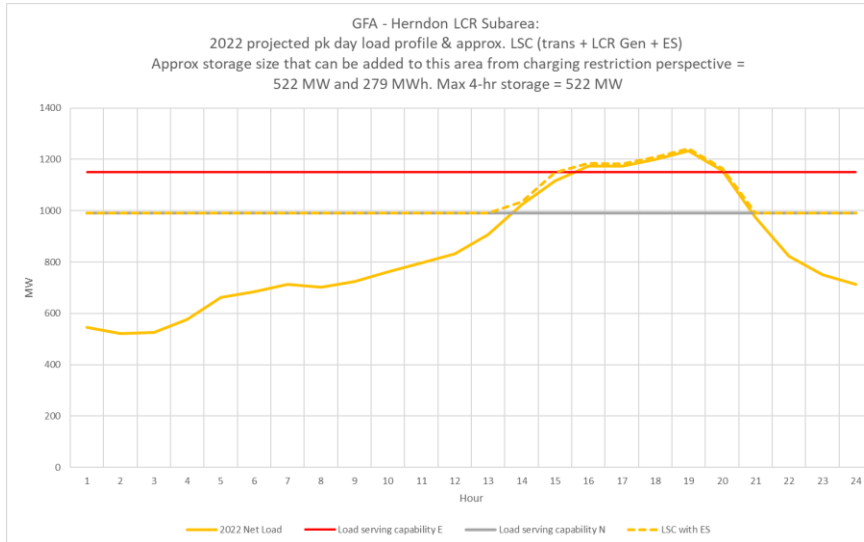

Overall Load and Resources

Load (MW)	2022	2026	Generation (MW)	2022	2026
Gross Load	3339	3472	Market/Net Seller	2515	2515
AAEE	-23	-47	Solar	361	361
Behind the meter DG	0	0	MUNI	212	212
Net Load	3315	3425	QF	4	4
Transmission Losses	120	146	Battery	300	300
Pumps	0	0			
Load + Losses + Pumps	3435	3571	Total Qualifying Capacity	3392	3392

Overall Sub-Area Requirements

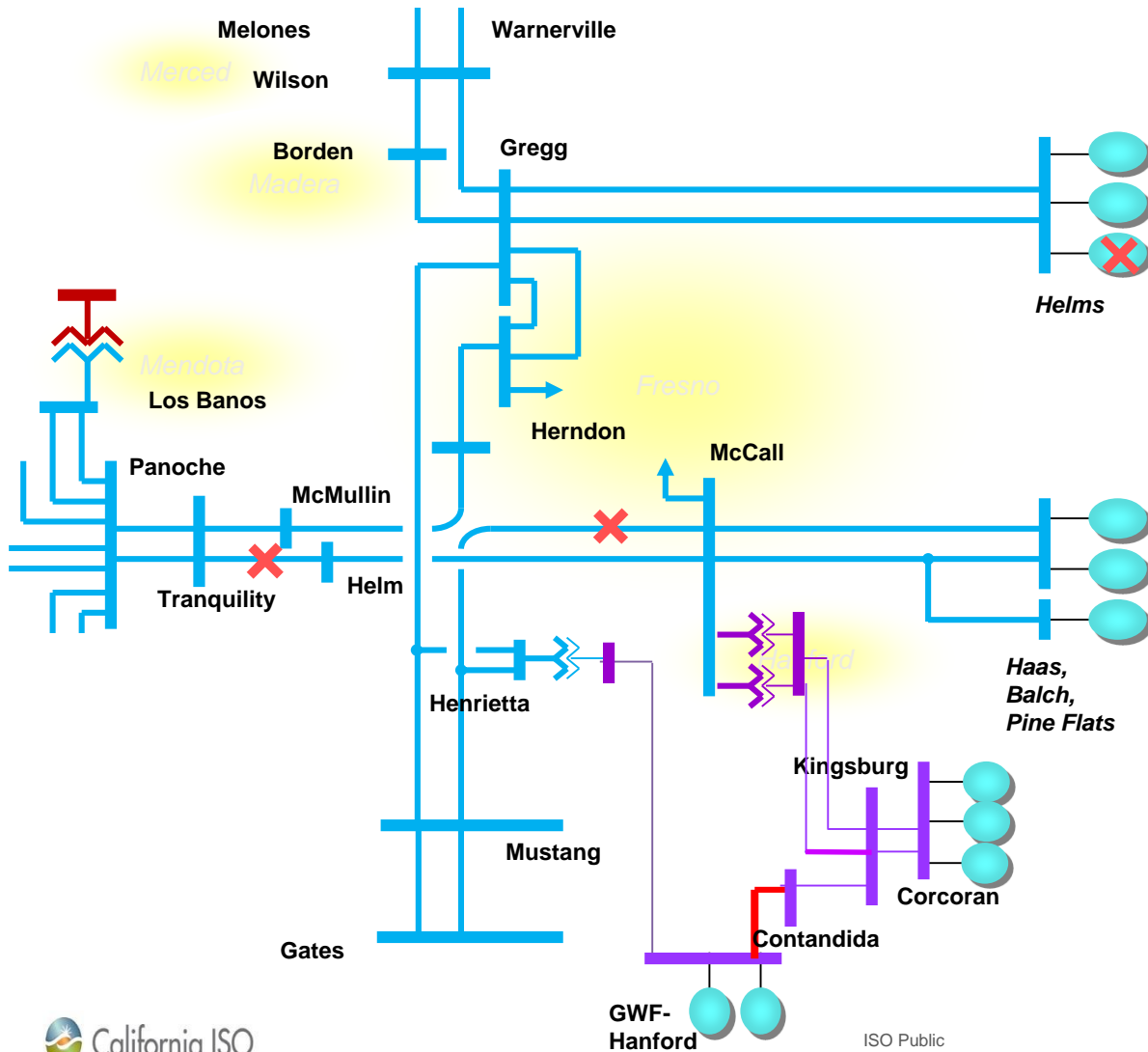

Overall Fresno Area : Requirements

Limit	Category	Limiting Facility	Contingency	2022 LCR (MW)	2026 LCR (MW)
First limit	P6	GWF-Contandida 115kV Line	Panoche-Helm 230kV Line and Gates-McCall 230kV line	1987	2314

Study Year	Existing Generation Capacity Needed (MW)	Deficiency (MW)	Total MW Need
2022	1987	378	2365
2026	2314	182	2496

Overall Sub-area: Load Profiles

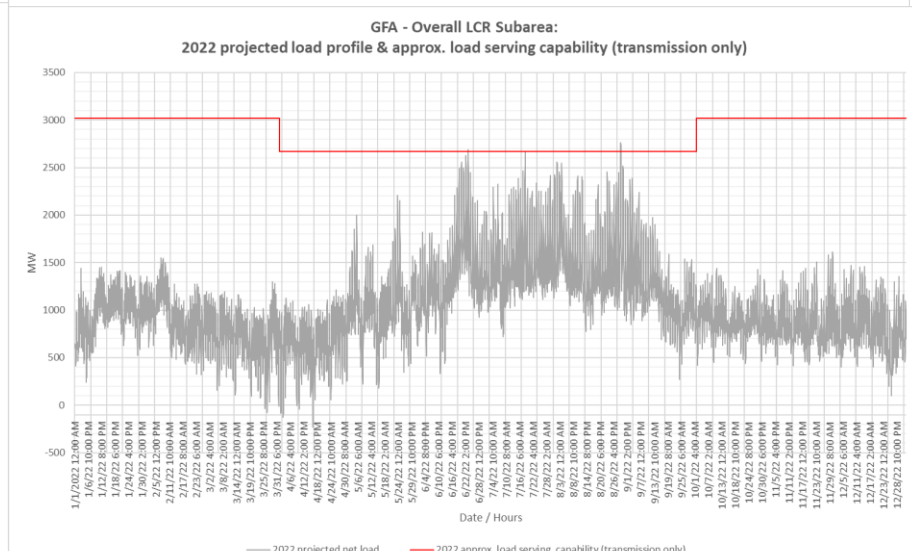
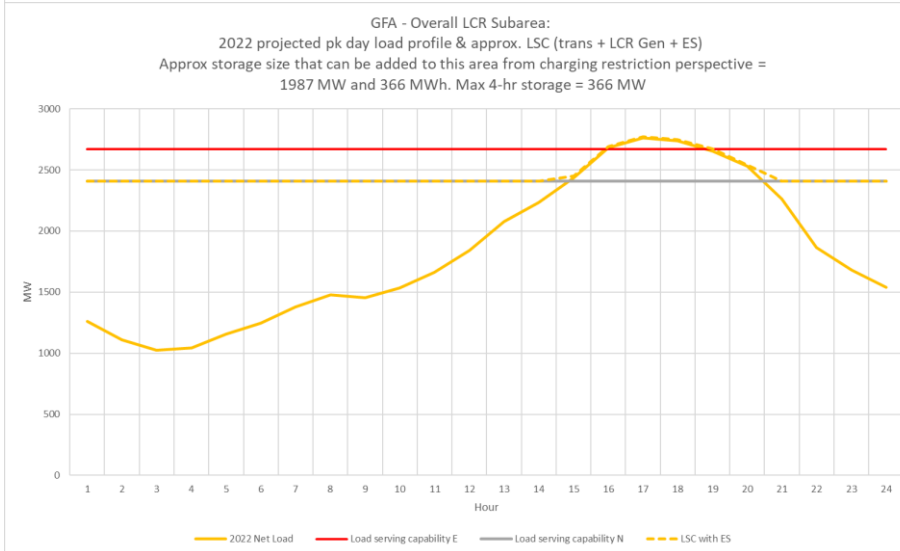
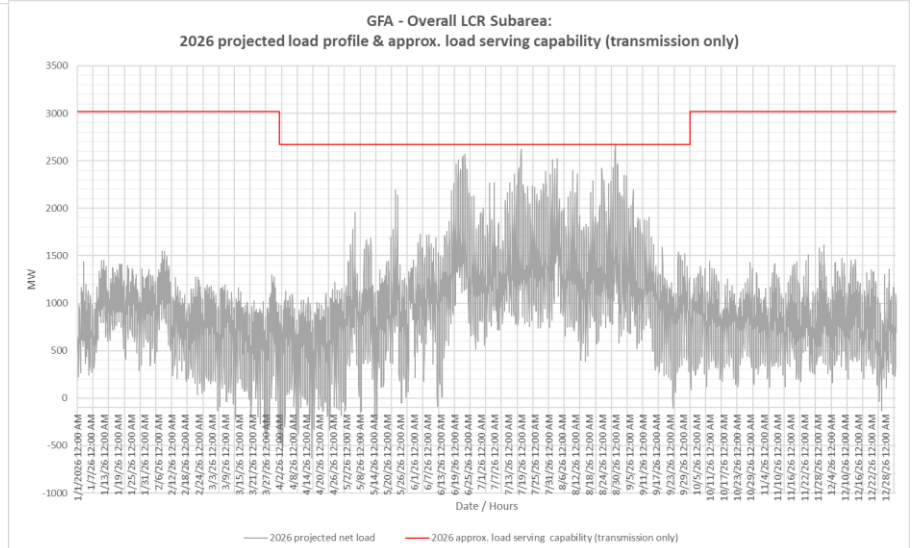
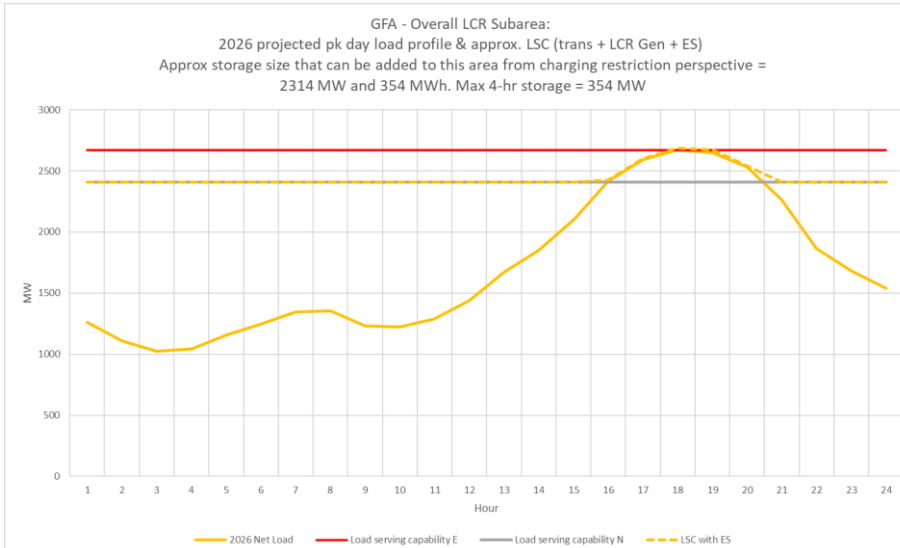

Changes Compared to Previous LCR Requirements

Sub-area	2021		2022		2025		2026	
	Load	LCR	Load	LCR	Load	LCR	Load	LCR
Hanford	209	58	209	70	210	58	214	76
Coalinga	93	57 (41)	119	95 (92 Peak; 79 NQC)	89	52 (36)	121	96 (93 Peak; 79 NQC)
Borden	133	0	149	35 (2 Peak)	137	4	154	35 (5 Peak)
Reedley	195	83 (32)	233	144 (93)	219	91 (40)	252	154 (103)
Panoche 115 kV	424	198	475	320	430	164	491	378
Wilson 115/70 kV	Flow-Through	416 (2)	Flow-Through	620 (306 Peak; 206 NQC)	N/A	Eliminated due to Project	Flow-Through	403 (89 Peak)
Herndon	1486	334	1600	522	1532	441	1669	526
Overall	3189	1694	3435	1987	3279	1971	3571	2314

LCR increase mostly due to increase in load forecast.