



2025 & 2029 Draft LCR Study Results Greater Bay Area

Uriel Rangel Diaz

Senior Regional Transmission Engineer

Stakeholder Call

March 6, 2024

Greater Bay Area Transmission System & LCR Subareas

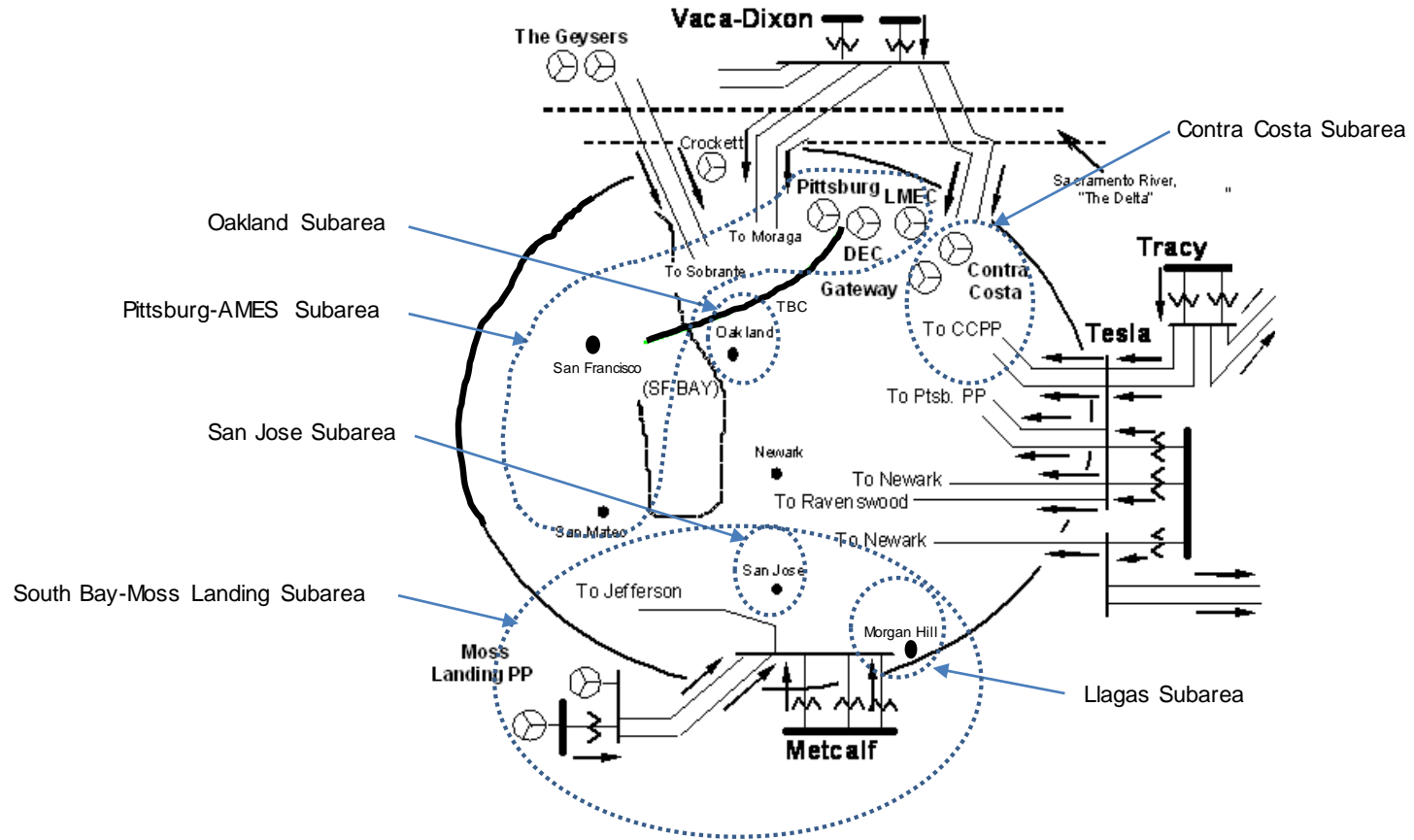

New major transmission projects

Project Name	Division	In Service Year
Moraga-Castro Valley 230 kV Line Capacity Increase Project	Diablo	2024
Pittsburg 230/115 kV Transformer Capacity Increase	Diablo	2026
Lone Tree – Cayetano – Newark corridor Series Compensation	Diablo	2027
New Collinsville 500 kV substation	Diablo	2027
Oakland Clean Energy Initiative (The Oakland X 115 kV Bus Upgrade in-service as for 2022)	East Bay	2025
Christie-Sobrante 115 kV Line Reconductor	East Bay	2028
Ravenswood 230/115 kV transformer #1 Limiting Facility Upgrade	Peninsula	2025
South of San Mateo Capacity Increase	Peninsula	2027
Redwood City Area 115 kV System Reinforcement	Peninsula	2030
Series Compensation on Los Esteros-Nortech 115 kV Line	San Jose	2024
Newark-Milpitas #1 115 kV Line Limiting Facility Upgrade	San Jose	2024
Vasona-Metcalf 230 kV Line Limiting Elements Removal Project	San Jose	2025
Metcalf-Piercy & Swift and Newark-Dixon Landing 115 kV Upgrade	San Jose	2027
Morgan Hill Area Reinforcement (formerly Spring 230/115 kV substation)	San Jose	2027
San Jose Area HVDC Line (Metcalf – San Jose)	San Jose	2028
San Jose Area HVDC Line (Newark - NRS)	San Jose	2027

Power Plant Changes

Additions modeled in 2025 & 2029:

- Plano BESS 1-4
- 16 new smaller resources – most energy only

Retirements:

- None

Llagas Sub-area: Load and Resources

Load (MW)	2025	2029	Generation (MW)	Aug NQC
Gross Load	233	253	Market/Net Seller	256
AAEE	-2	-3	Battery	0
Behind the meter DG	-3	-3	Muni/QF	0
Net Load	228	248	Solar	0
Transmission Losses	1	1	Existing 20-minute Demand Response	0
Pumps	0	0	Mothballed	0
Load + Losses + Pumps	229	249	Total	256

Llagas Sub-area: One-line diagram

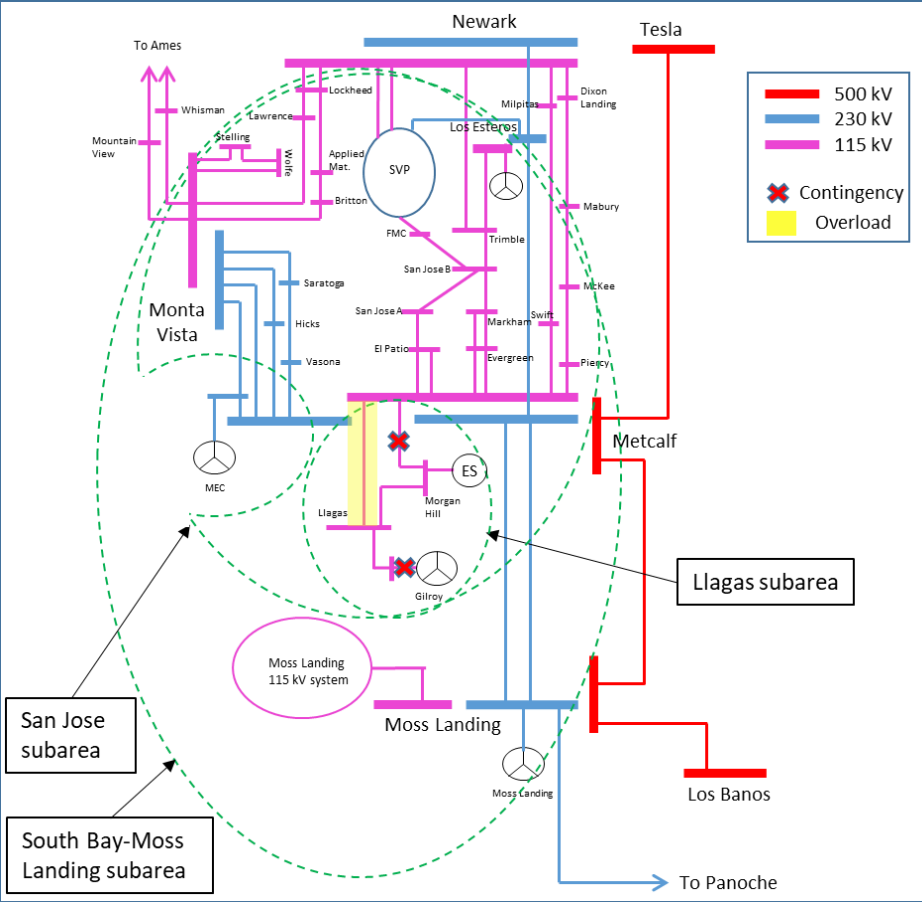

2025

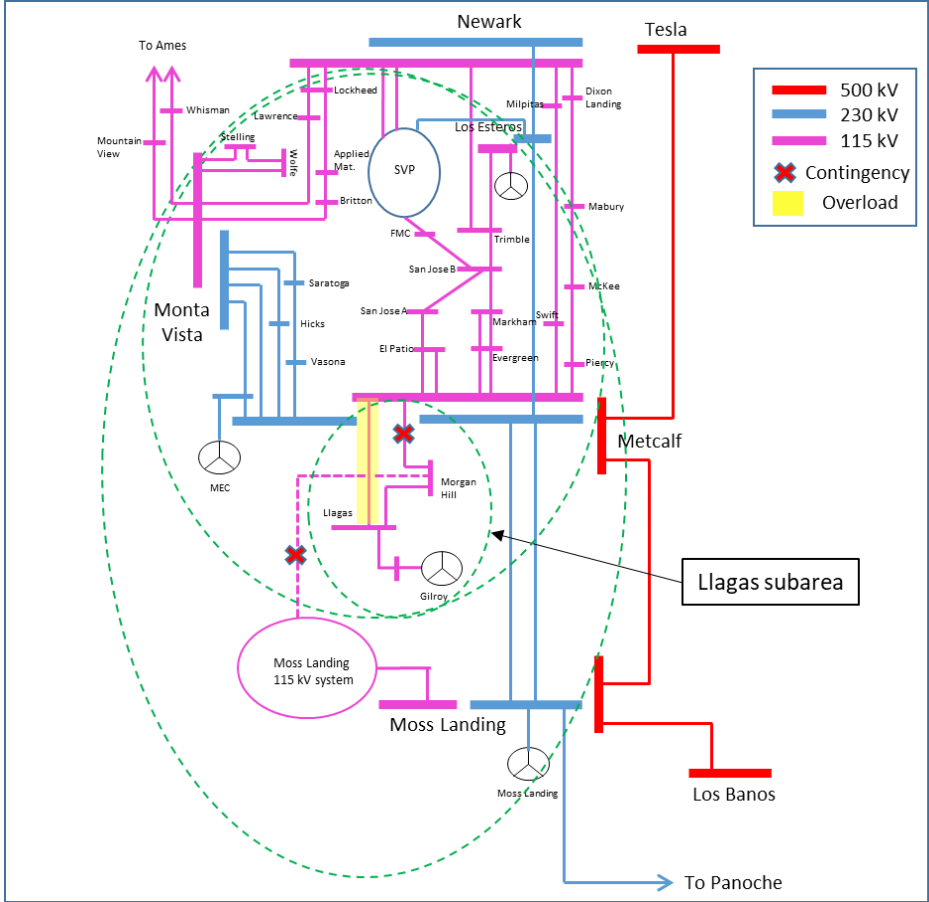

2029

Llagas Sub-area: Requirements

Year	Category	Limiting Facility	Contingency	LCR (MW)
2025	P3	Metcalf-Llagas 115 kV line	Metcalf-Morgan Hill + Gilroy Cogen Unit 1	60
2029	P6	Metcalf-Llagas 115 kV line	Metcalf-Morgan Hill & Morgan Hill-Green Valley 115 kV lines	80

*The worst contingency in the Llagas sub-area change in the 2029 scenario when the Morgan Hill Area Reinforcement (formerly Spring 230/115 kV substation) project becomes operational.

Llagas Sub-area: Load Profiles

GBA - Llagas LCR Subarea:
 2025 projected pk day load profile & approx. LSC (trans + LCR Gen + ES)
 Approx storage size that can be added to this area from charging restriction perspective =
 110 MWh and 231 MWh. Max 4-hr storage = 24 MW

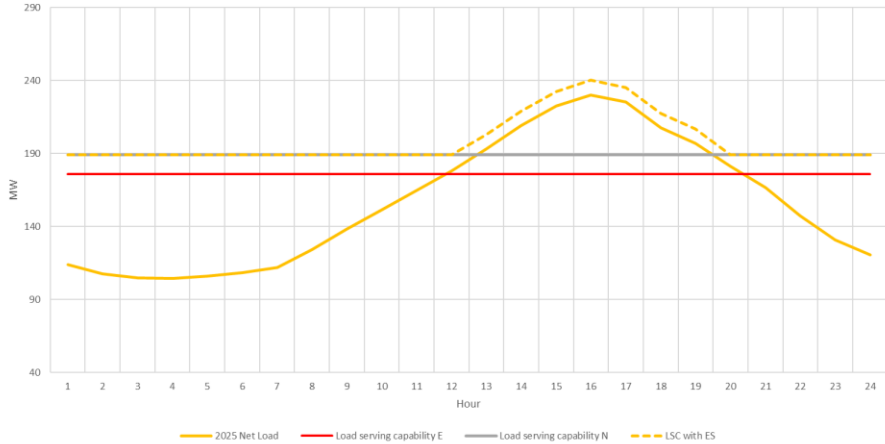

GBA - Llagas LCR Subarea:
 2025 projected load profile & approx. load serving capability (transmission only)

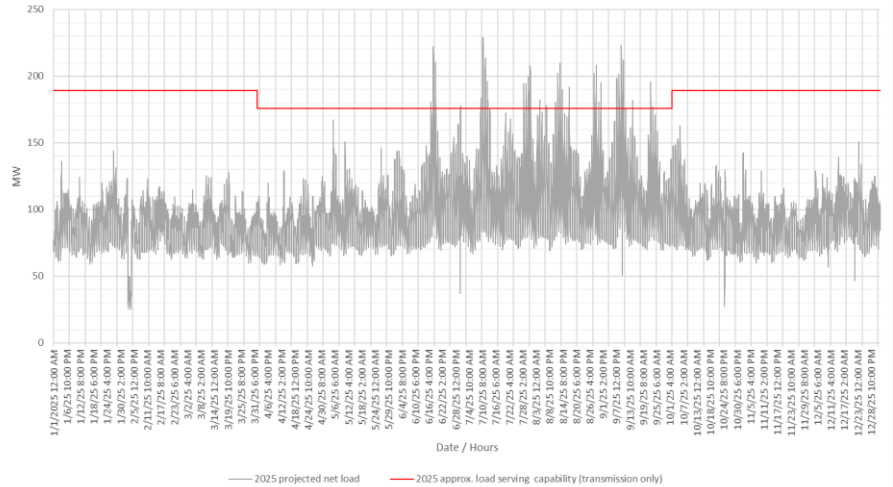

GBA - Llagas LCR Subarea:
 2029 projected pk day load profile & approx. LSC (trans + LCR Gen + ES)
 Approx storage size that can be added to this area from charging restriction perspective =
 100 MWh and 385 MWh. Max 4-hr storage = 24 MW

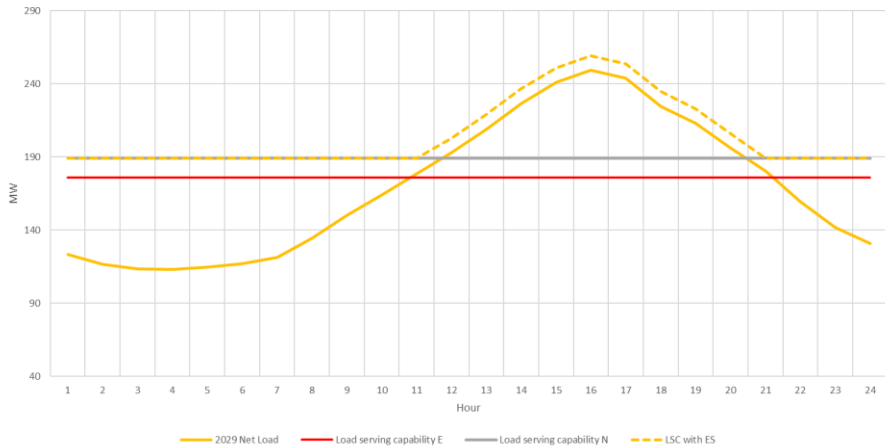

GBA - Llagas LCR Subarea:
 2029 projected load profile & approx. load serving capability (transmission only)

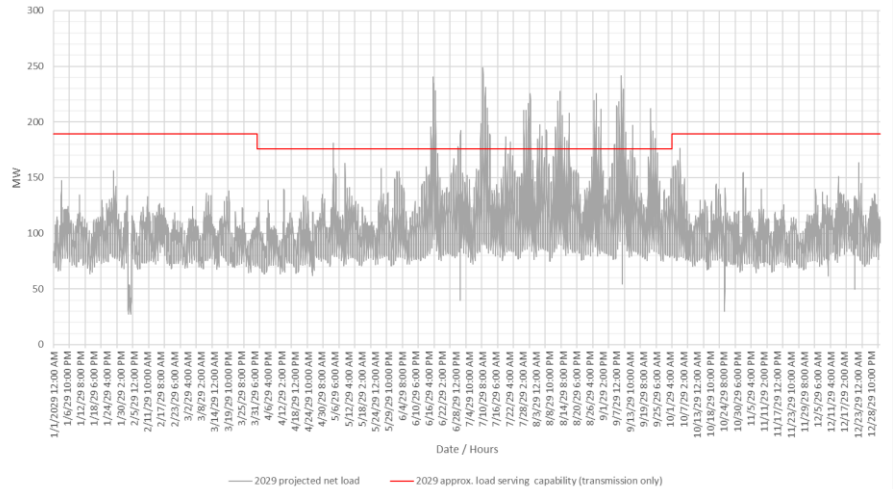

San Jose Sub-area: Load and Resources

Load (MW)	2025	2029	Generation (MW)	Aug NQC
Gross Load	2,909	3,259	Market/Net Seller	584
AEE	-21	-34	Battery	75
Behind the meter DG	-22	-22	Muni/QF	197
Net Load	2,867	3,204	Solar	0
Transmission Losses	130	84	Existing 20-minute Demand Response	0
Pumps	0	0	Mothballed	0
Load + Losses + Pumps	2,997	3,288	Total	856

San Jose Sub-area: One-line diagram

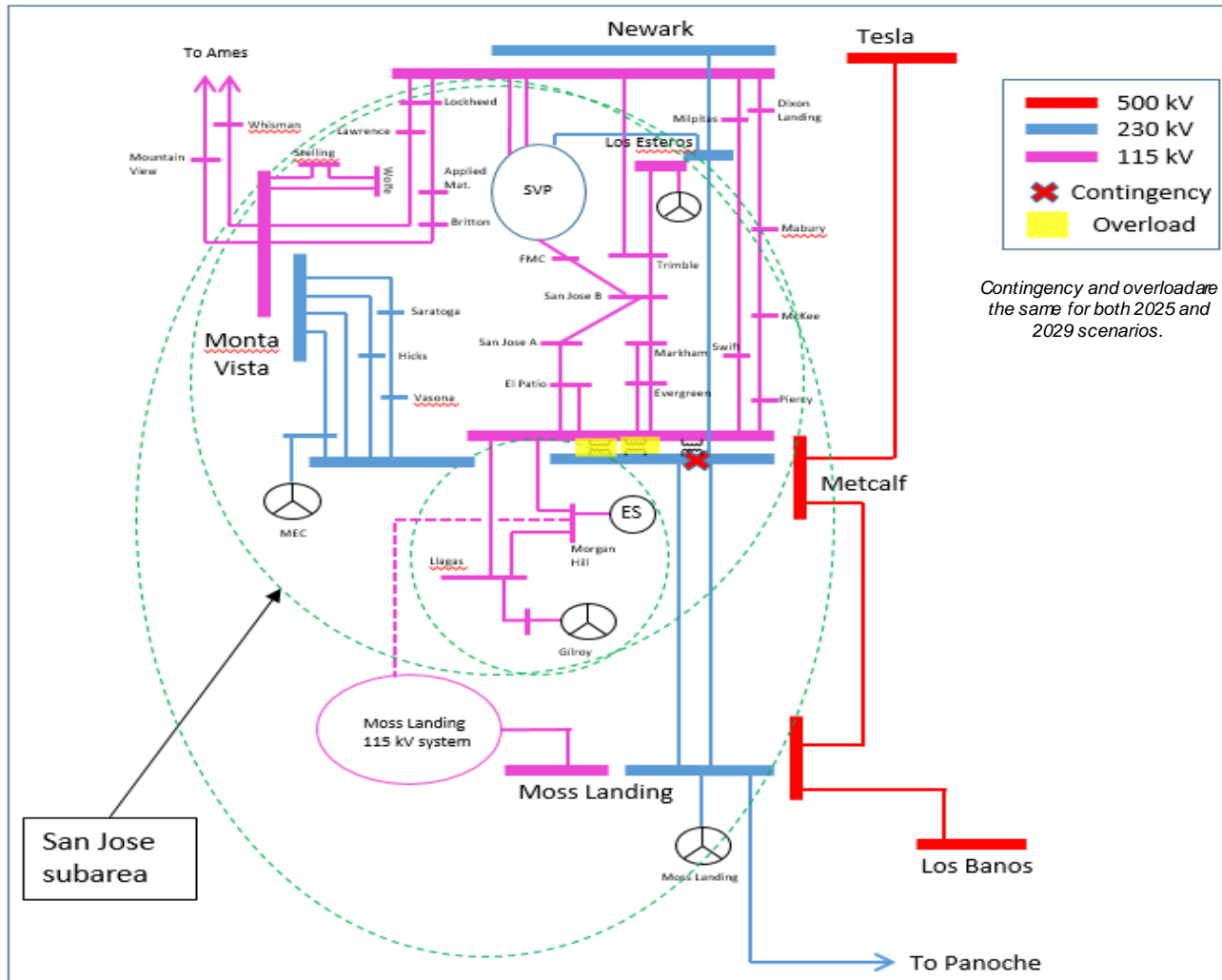

San Jose Sub-area: Requirements

Year	Category	Limiting Facility	Contingency	LCR (MW) (deficiency)
2025	P2	Metcalf 230/115 kV transformer # 1 or # 3	Metcalf 230 kV Bus Section 2D & 2E	1,418 (562)
2029	P2	Metcalf 230/115 kV transformer # 1 or # 3	Metcalf 230 kV Bus Section 2D & 2E	183

San Jose Sub-area: Load Profiles

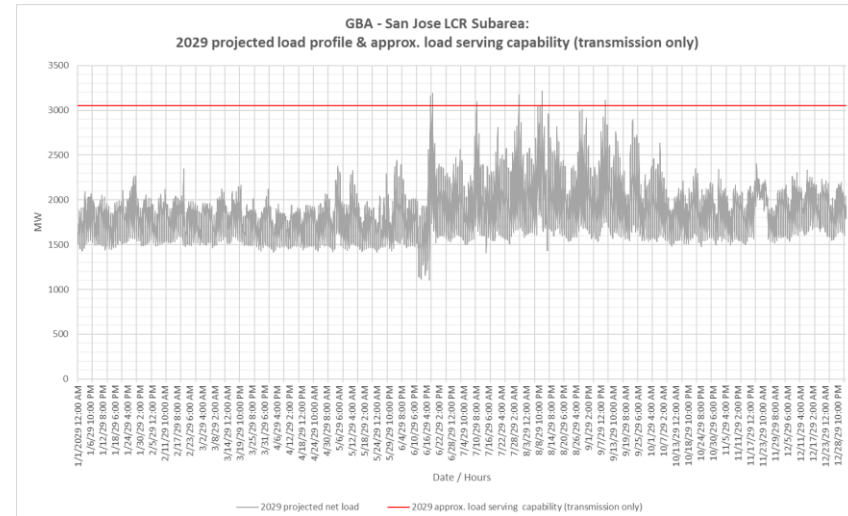
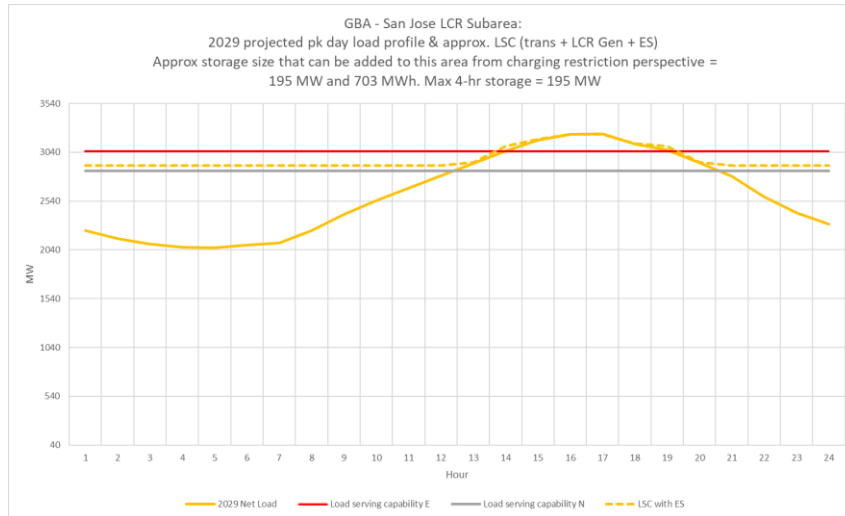
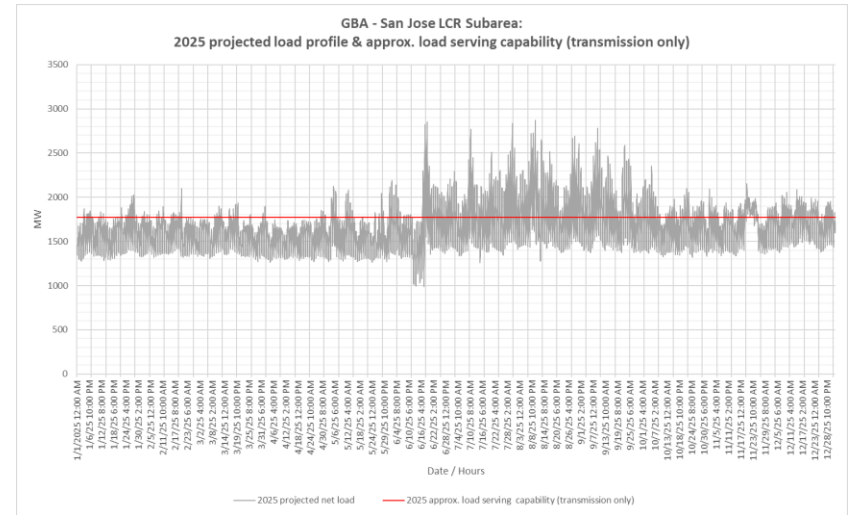
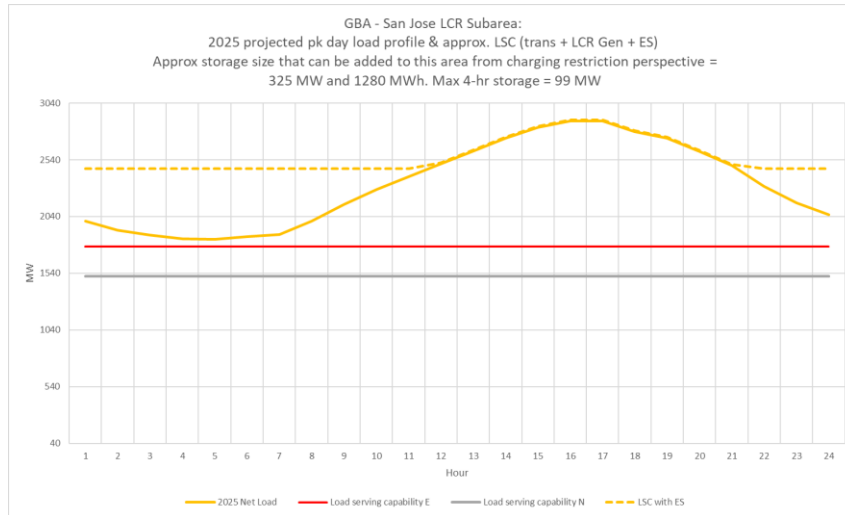

South Bay-Moss Landing Sub-area: Load and Resources

Load (MW)	2025	2029	Generation (MW)	Aug NQC
Gross Load	4,555	4,886	Market/Net Seller	2,201
AEE	-35	-58	Battery	1,008
Behind the meter DG	-47	-47	Muni/QF	197
Net Load	4,473	4,781	Solar	0
Transmission Losses	166	129	Existing 20-minute Demand Response	0
Pumps	0	0	Mothballed	0
Load + Losses + Pumps	4,639	4,910	Total	3,406

South Bay-Moss Landing Sub-area: One-line diagram

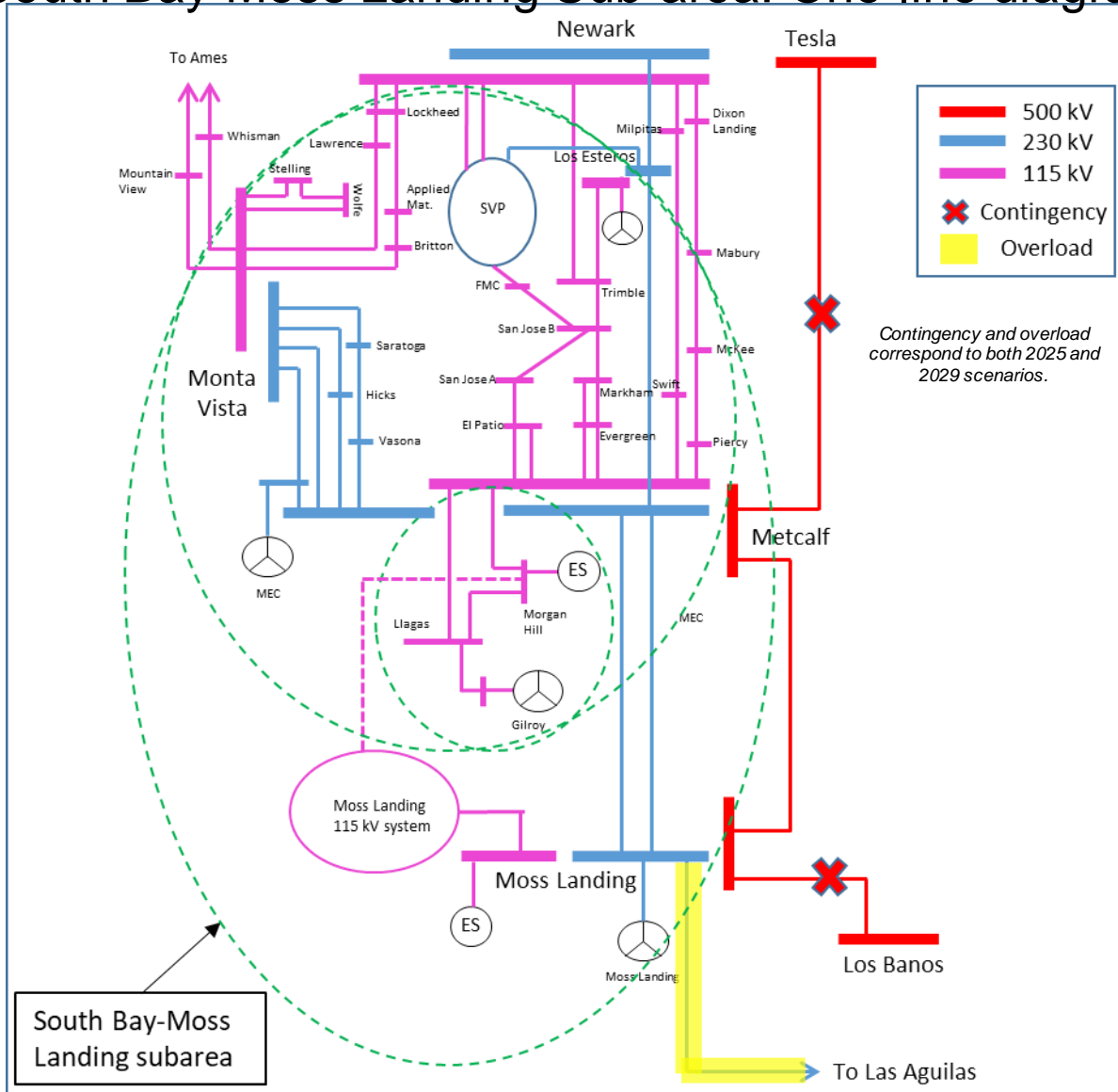

South Bay-Moss Landing Sub-area: Requirements

Year	Category	Limiting Facility	Contingency	LCR (MW)
2025	P6	Moss Landing-Las Aguilas 230 kV	Tesla-Metcalf 500 kV and Moss Landing-Los Banos 500 kV	2,399
2029	P6	Moss Landing-Las Aguilas 230 kV	Tesla-Metcalf 500 kV and Moss Landing-Los Banos 500 kV	2,325

South Bay-Moss Landing Sub-area: Load Profiles

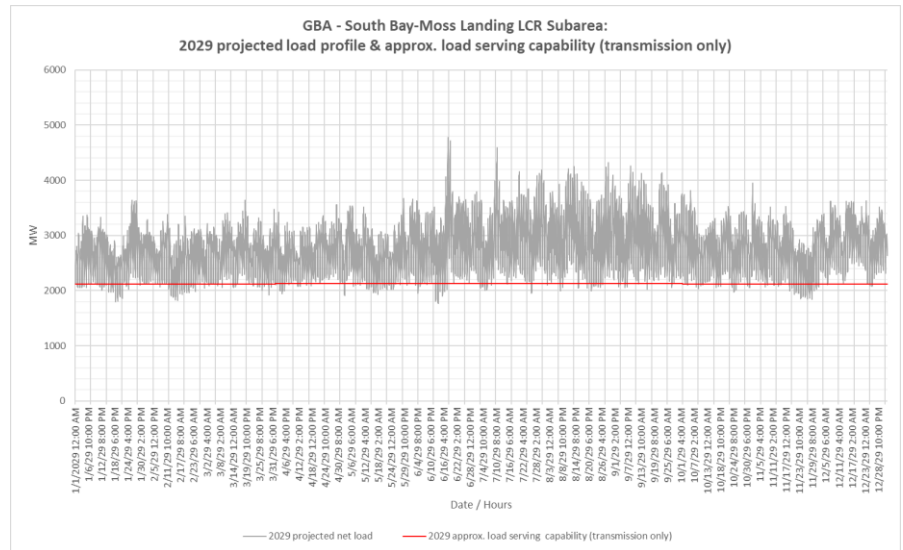
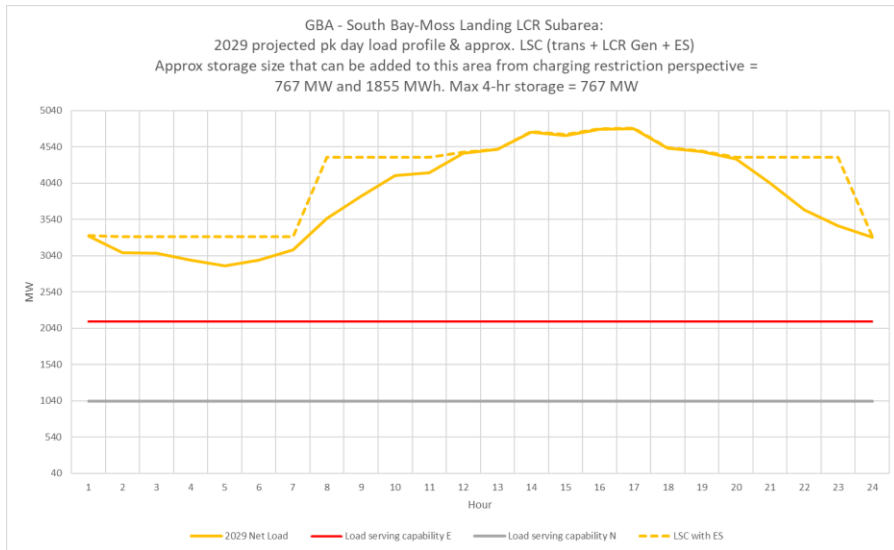
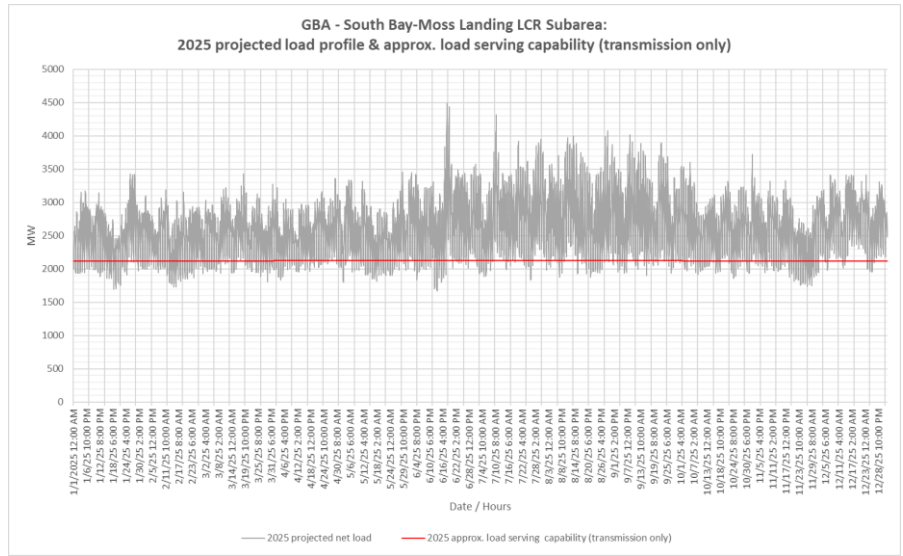
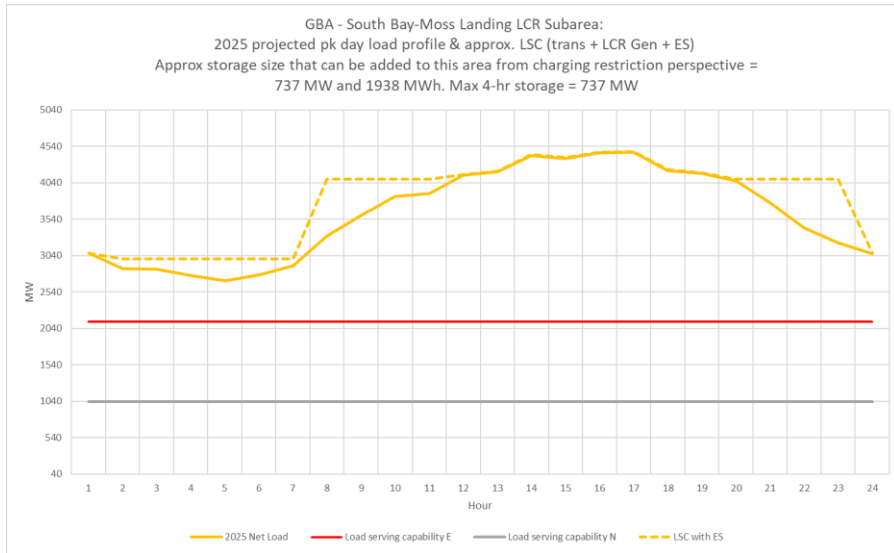

Oakland Sub-area: Load and Resources

Load (MW)	2025	2029	Generation (MW)	Aug NQC
Gross Load	439	441	Market/Net Seller	110
AAEE	-3	-5	Battery	0
Behind the meter DG	-3	-3	Muni/QF	49
Net Load	433	433	Solar	0
Transmission Losses	1	1	Existing 20-minute Demand Response	0
Pumps	0	0	Mothball	0
Load + Losses + Pumps	434	434	Total	159

Oakland Sub-area: One-line diagram

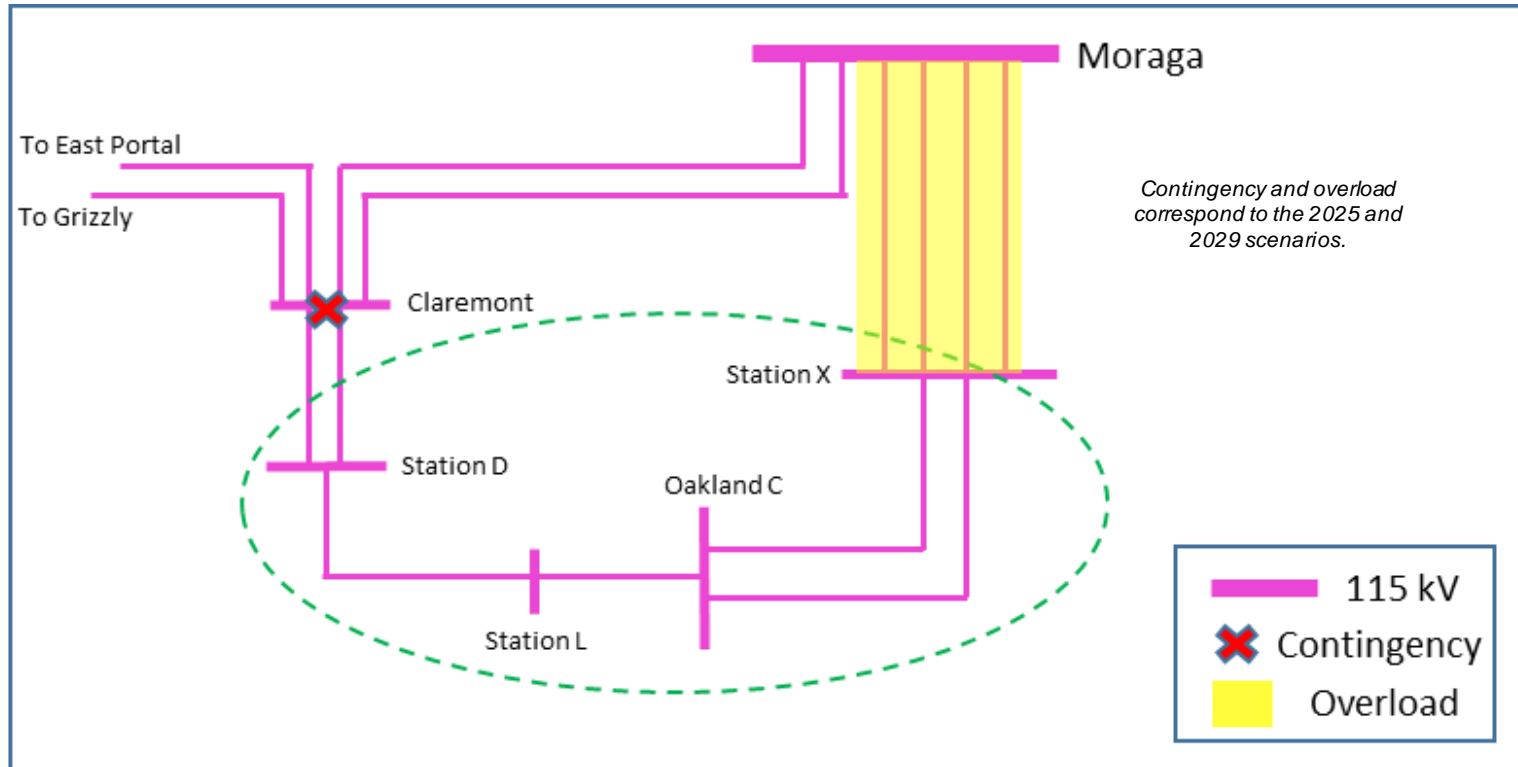

Oakland Sub-area: Requirements

Year	Category	Limiting Facility	Contingency	LCR (MW)
2025	P2	Moraga D – Oakland X #1-4	Claremont 115 kV Section 1D & 2D	101
2029	P2	Moraga D – Oakland X #1-4	Claremont 115 kV Section 1D & 2D	103

Note:

** Due to the load forecast increase in this TPP cycle, the pocket definition changed with respect the past LCR study. Loads in Stations X, D and L were included in the pocket. Additionally, the contingencies definition changed due to the projects in the area.*

Ames-Pittsburg-Oakland Sub-area: Load and Resources

Load (MW)	2025	2029	Generation (MW)	Aug NQC
Gross Load	NA – Flow through area.		Market/Net Seller	2,266
AAEE			Battery	270
Behind the meter DG			Muni/QF	274
Net Load			Solar	2
Transmission Losses			Existing 20-minute Demand Response	0
Pumps			Mothballed	0
Load + Losses + Pumps			Total Qualifying Capacity	2,812

Ames/Pittsburg/Oakland Sub-area: Requirements

Year	Category	Limiting Facility	Contingency	LCR (MW) (deficiency)
2025	P6	Ames-Ravenswood #1 & #2 115 kV lines	Newark-Ravenswood & Tesla-Ravenswood 230 kV lines	2,606
2029	P6	East Shore – San Mateo 230 kV line	Newark-Ravenswood & Tesla-Ravenswood 230 kV lines	1,327

Contra Costa Sub-area: Load and Resources

Load (MW)	2025	2029	Generation (MW)	Aug NQC
Gross Load	NA – Flow through area.		Market/Net Seller	1,662
AAEE			Wind	248
Behind the meter DG			Battery	0
Net Load			Muni/QF	127
Transmission Losses			Solar	0
Pumps			Existing 20-minute Demand Response	0
Load + Losses + Pumps			Total	2,037

Contra Costa Sub-area: One-line diagram

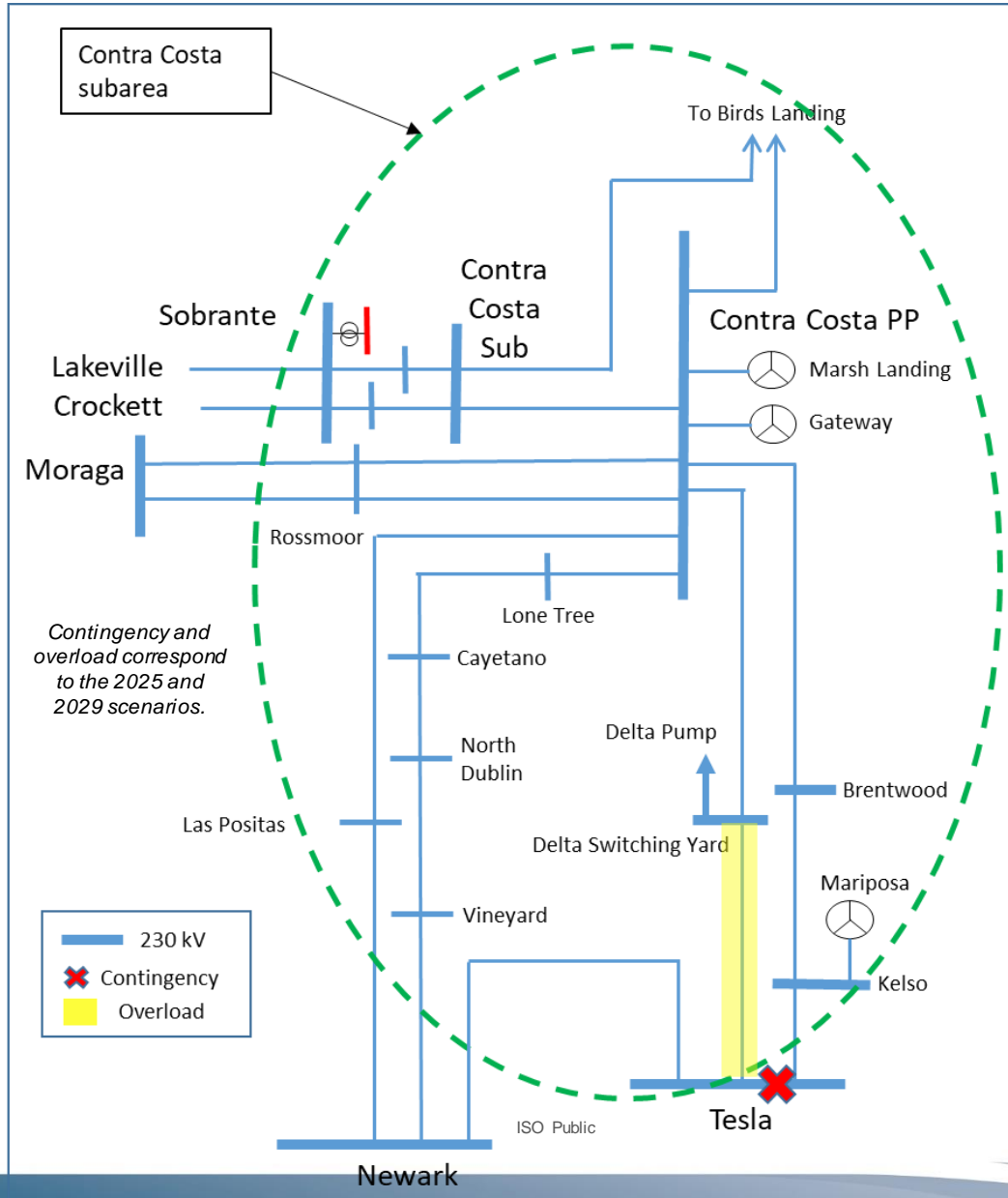

Contra Costa Sub-area: Requirements

Year	Category	Limiting Facility	Contingency	LCR (MW) (deficiency)
2025	P2	Tesla – Newark 230 kV line	Tesla 230 kV Section 2E & 1E	948
2029	P2	Tesla – Newark 230 kV line	Tesla 230 kV Section 2E & 1E	478

Greater Bay Area Overall: Load and Resources

Load (MW)	2025	2029	Generation (MW)	Aug NQC
Gross Load	11,570	12,020	Market/Net Seller	6,131
AAEE	-83	-144	Wind	248
Behind the meter DG	-119	-119	Battery	1,277
Net Load	11,368	11,757	Muni/QF	604
Transmission Losses	360	312	Solar	4
Pumps	264	264	Existing 20-minute Demand Response	65
Load + Losses + Pumps	11,992	12,333	Total	8,329

Greater Bay Area Overall: Requirements

Year	Category	Limiting Facility	Contingency	LCR (MW) (deficiency)
2025	P6	Metcalf 500/230 kV #13 transformer	Metcalf 500/230 kV #11 & #12 transformers	7,976 (595)
2029	P6	Metcalf 500/230 kV #13 transformer	Metcalf 500/230 kV #11 & #12 transformers	6,259

Greater Bay Area Sub-area: Load Profiles

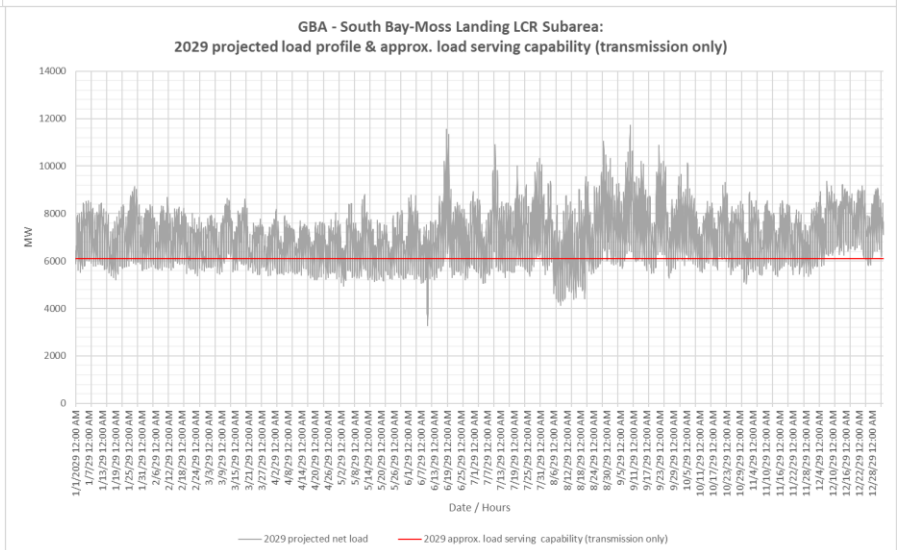
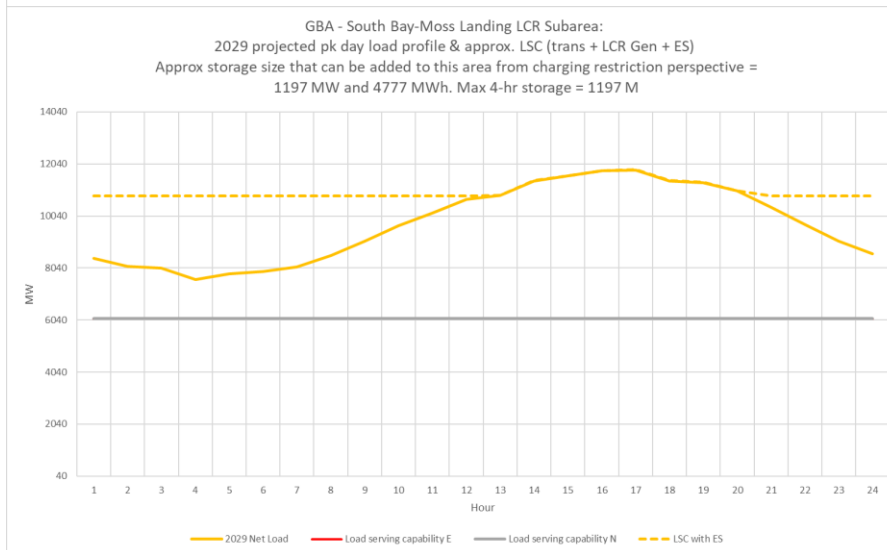
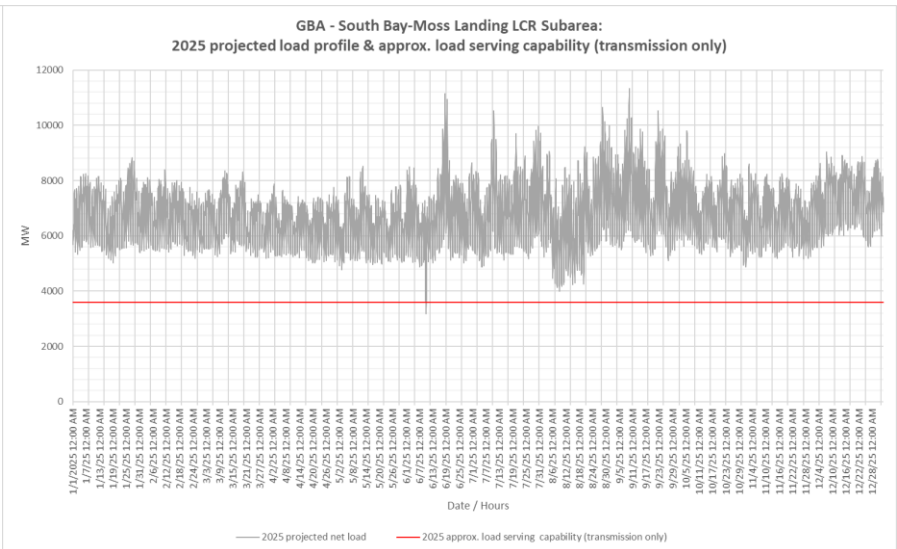
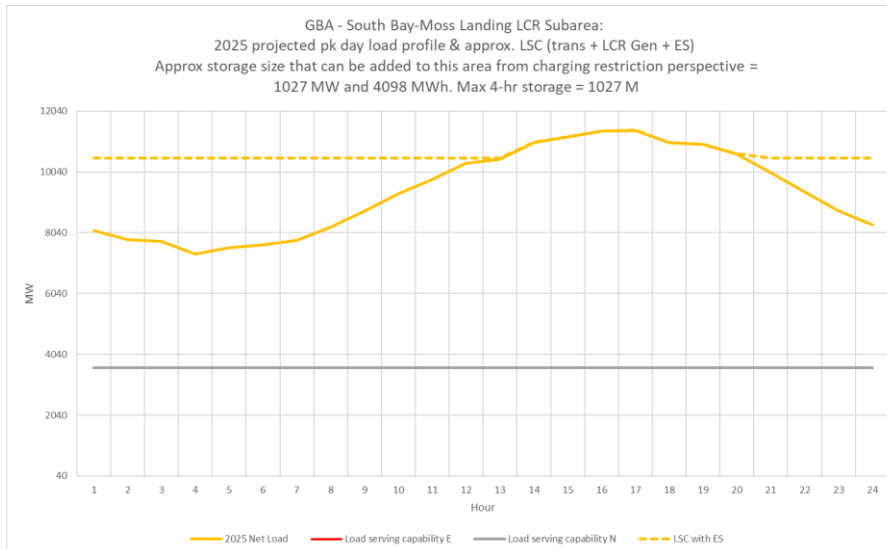

Greater Bay Area Total Generation & LCR Need

Generation	Market/Net Seller (MW)	Wind (MW)	Muni/QF (MW)	Solar (MW)	Existing 20-minute Demand Response (MW)	Battery (MW)	Total MW
Aug NQC	6,131	248	604	4	65	1277	8,329

Year	Existing Generation Capacity Needed (MW)	Deficiency (MW)	Total MW Need
2025	7,381	595	7,976
2029	6,259	0	6,259

The overall LCR requirement has increased in 2025 mostly due to load growth. The overall LCR requirement has decreased in 2029 mostly due to approved projects.

Changes Compared to Previous Year's LCR Requirements

Sub-area	2024		2025		2028		2029	
	Load	LCR	Load	LCR	Load	LCR	Load	LCR
Llagas	264	158	229	60	286	131	249	80
San Jose	2,845	1,170 (324)	2,997	1,418 (530)	3,141	200	3,288	183
South Bay – Moss Landing	4,447	2,124	4,639	2,399	4,848	2,385	4,910	2,325
Oakland*	175*	113	434	101	184	40	434	103
Pittsburg – Ames – Oakland	NA*	2,086	NA*	2,606 (18)	NA*	1,787	NA*	1,327
Contra Costa	NA*	960	NA*	948	NA*	737	NA*	478
Overall	11,081	7,329	11,992	7,976 (633)	11,757	6,261	12,333	6,259