

# APPENDIX F: Policy Assessment

Intentionally left blank

## F.1. Overview of the ISO Policy-Driven Need Assessment

### F.1.1. Background

The overarching public policy objective for the California ISO's Policy-Driven Need Assessment is the state's mandate for meeting renewable energy and greenhouse gas (GHG) reduction targets while maintaining reliability. For the purposes of the transmission planning process, this high-level objective is comprised of two sub-objectives: first, to support Resource Adequacy (RA) deliverability status for the renewable generation and energy storage resources identified in the portfolio as requiring that status, and second, to support the economic delivery of renewable energy over the course of all hours of the year.

The more coordinated and proactive approach taken in the ISO's current annual transmission planning process is part of a larger set of interrelated and coordinated planning and resource development activities being undertaken between the state energy agencies and the ISO. The ISO, for example, relies in particular on the CPUC for its lead role in developing resource forecasts for the long-term planning horizon, with both the ISO and CEC providing input to the CPUC for those resource forecasts. The ISO also relies on the CEC for its lead role in forecasting customer load requirements and the MOU signed by the three parties in December 2022 reaffirms our respective roles and commitment to ensure we are working in concert with one another. As such, the MOU also sets the overall strategic direction for tightening linkages among resource and transmission planning activities, interconnection processes and resource procurement so the three entities are synchronized in working for the timely integration of new resources.

The CPUC issued a Decision on February 8, 2018, which adopted the integrated resource planning (IRP) process designed to ensure that the electric sector is on track to help the State achieve its 2030 GHG reduction target, at least cost, while maintaining electric service reliability and meeting other state goals. In subsequent years, the CPUC has been developing integrated resource plans and transmitting them to the ISO for use in the annual transmission planning process.

The CPUC issued Decision 25-02-026 adopting a base case portfolio and a sensitivity portfolio for use in the 2025-2026 Transmission Planning Process (TPP). The base case portfolio is based on the 25 million metric ton (MMT) greenhouse gas (GHG) target for the electric sector in 2035 and the California Energy Commission's 2023 Integrated Energy Policy Report demand forecast. The baseline portfolio is used to identify reliability and policy-driven transmission needs for approval in the ISO 2025-2026 TPP. The sensitivity portfolio is designed to help study the transmission implications of a portfolio with a

greater volume of long lead-time (LLT) resources as called for in Decision 24-08-064. The Decision is accompanied by a document entitled Modeling Assumptions for the 2025-2026 Transmission Planning Process, which provides the methodology and results of the resources-to-busbar mapping process as well as other assumptions for use in the ISO TPP.

### F.1.2. Objectives of Policy Driven Assessment

Key objectives of the policy-driven assessment are to:

- Assess the transmission impacts of portfolio resources using:
  - Reliability assessment;
  - Peak and Off-peak deliverability assessment; and
  - Production cost simulation;
- Identify transmission upgrades or other solutions needed to ensure reliability deliverability or alleviate excessive curtailment;
- Gain further insights to inform future portfolio development; and
- Set out the zonal capacities that are being established through coordinated transmission planning and resource planning, to shape and guide interconnection and resource procurement.

### F.1.3. Study Methodology and Components

The policy-driven assessment is an iterative process comprised of three types of technical studies as illustrated in Figure F.1-1. These studies are geared towards capturing the impact of the resource build-out on transmission infrastructure, identifying any required upgrades and generating transmission-related input for use by the CPUC in the next cycle of portfolio development.

Figure F.1-1: Policy-Driven Assessment Technical Studies

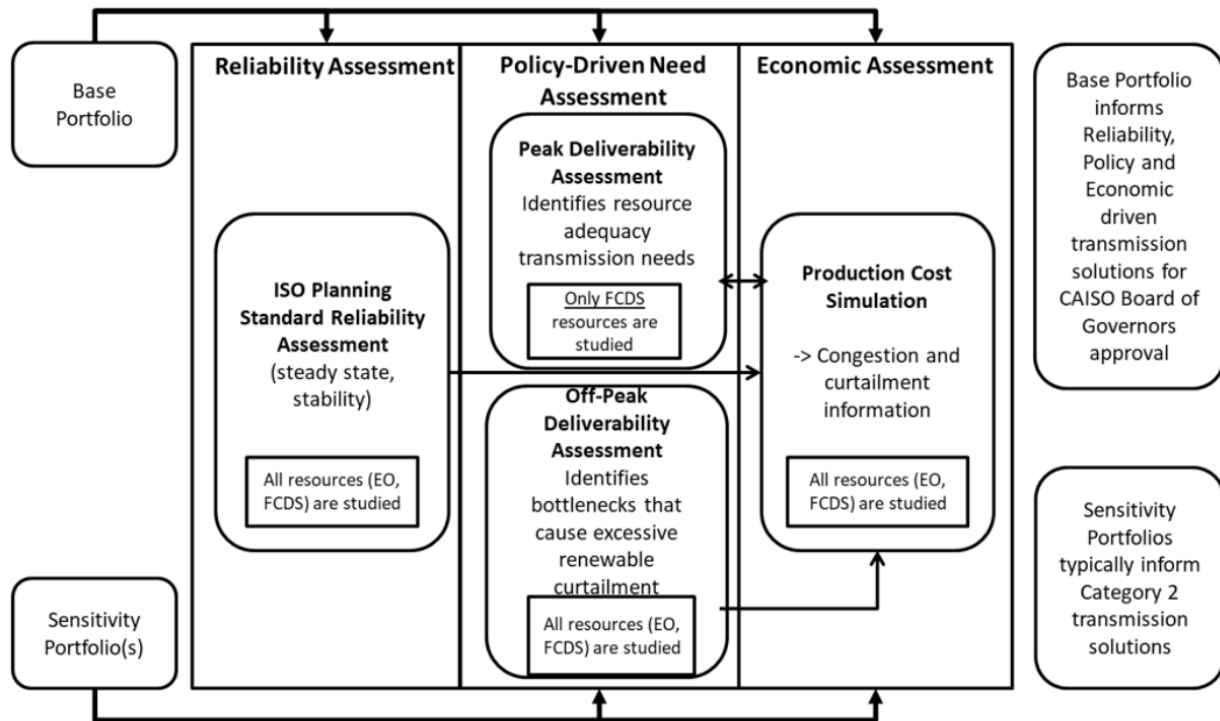

### Reliability assessment

The CPUC’s base resource portfolio is a key input in the ISO’s long term reliability assessment. The reliability assessment is used to assess transmission needs in accordance with NERC, WECC and ISO transmission planning standards and criteria. It is also used to identify constraints and potential solutions that may be modeled in production cost simulations to assess the impact of the constraints on congestion and renewable curtailment, which may lead to identification of economic transmission projects. The reliability assessment is presented in Chapter 2 and Appendix B.

### On-peak deliverability assessment

The on-peak deliverability assessment is designed to ensure portfolio resources selected with full capacity deliverability status (FCDS) are deliverable and can count towards meeting resource adequacy needs. The assessment examines whether sufficient transmission capability exists to transfer resource output from a given area to the aggregate of the ISO control-area load when the generation is needed most. The ISO performs the assessment in accordance with its On-peak Deliverability Assessment Methodology.

### Off-peak deliverability assessment

The off-peak deliverability assessment is performed to identify potential transmission system limitations that may cause excessive renewable energy curtailment. Like the reliability assessment, the off-peak assessment is also used to identify constraints and transmission solutions as candidates for detailed production cost simulation studies and economic assessment. The ISO performs the assessment in accordance with its Off-Peak Deliverability Assessment Methodology.

### Production cost model (PCM) simulation

Production cost models for the base and sensitivity portfolios are developed and simulated to identify renewable curtailment and transmission congestion in the ISO Balancing Authority Area. The PCM for the base and sensitivity portfolios are mainly used in the economic assessment covered in Chapter 4 and Appendix G. The PCM cases are developed based on study assumptions for the ISO-controlled grid outlined in the 2025-2026 transmission planning process study plan. Details of PCM modeling assumptions and approaches are provided in Appendix G.

## F.2. Resource Portfolios

As mentioned in Section F.1, the base portfolio and long lead-time resources sensitivity portfolio were transmitted by the CPUC for study in the ISO 2025-2026 transmission planning process. The portfolio documents are available on the CPUC website.

The following documents provide details regarding the base portfolio.

The final 2035 and 2040 busbar mapping results for the base portfolio:

[https://files.cpuc.ca.gov/energy/modeling/LTPP/Full-Dashboard\\_25-26TPP\\_BaseCaseD\\_2025-02-20.xlsx](https://files.cpuc.ca.gov/energy/modeling/LTPP/Full-Dashboard_25-26TPP_BaseCaseD_2025-02-20.xlsx)

The final 2035 and 2040 busbar mapping results for the high gas generation retirement sensitivity portfolio:

[https://files.cpuc.ca.gov/energy/modeling/LTPP/Full-Dashboard\\_25-26TPP\\_LLTSensD\\_2025-02-20.xlsx](https://files.cpuc.ca.gov/energy/modeling/LTPP/Full-Dashboard_25-26TPP_LLTSensD_2025-02-20.xlsx)

The baseline reconciliation and in-development resources:

[https://www.cpuc.ca.gov/-/media/cpuc-website/divisions/energy-division/documents/integrated-resource-plan-and-long-term-procurement-plan-irp-ltpp/2024-2026-irp-cycle-events-and-materials/assumptions-for-the-2025-2026-tpp/baselinereconcile\\_25-6tpp\\_pupdate.xlsx](https://www.cpuc.ca.gov/-/media/cpuc-website/divisions/energy-division/documents/integrated-resource-plan-and-long-term-procurement-plan-irp-ltpp/2024-2026-irp-cycle-events-and-materials/assumptions-for-the-2025-2026-tpp/baselinereconcile_25-6tpp_pupdate.xlsx)

The composition of each of the portfolios by resource type is provided in Table F.2-1. The table includes resources selected with Full Capacity Deliverability Status (FCDS) as well as those selected as Energy Only (EO). The numbers also include any portfolio adjustments based on CPUC guidance including unaccounted for TPD allocation modeled, additional in-development resources modeled by PTOs based on projects status and non-CPUC jurisdictional portfolios. The portfolios are comprised of solar, wind (in-state, out-of-state and offshore), battery storage, geothermal, long duration energy storage, biomass/biogas and distributed solar resources. All portfolio resources are modeled in policy-driven assessments except in the on-peak deliverability assessment in which only FCDS resources are modeled. The portfolios assume some of the existing gas-fired generation fleet will be retired.

Table F.2-1: Portfolio Composition – FCDS + EO Resources (MW)

Resource Type	2035 Base Portfolio			2040 Base Portfolio			2035 Sensitivity Portfolio		
	FCDS (MW)	EO (MW)	Total (MW)	FCDS (MW)	EO (MW)	Total (MW)	FCDS (MW)	EO (MW)	Total (MW)
Solar	6,611	13,266	19,876	14,728	29,890	44,619	6,379	11,435	17,814
Wind – In State	6,750	1,157	7,908	6,750	1,157	7,908	5,981	954	6,936
Wind – Out-of-State	9,000	0	9,000	10,707	0	10,707	7,000	0	7,000
Wind - Offshore	4,531	0	4,531	4,531	0	4,531	7,555	0	7,555
Li Battery – 4 hr	26,463	0	26,463	24,432	0	24,432	27,002	0	27,002
Li Battery – 8 hr	2,913	0	2,913	11,440	0	11,440	1,341	0	1,341
Long Duration Energy Storage (LDES)	1,197	0	1,197	1,197	0	1,197	2,582	0	2,582
Geothermal	1,649	0	1,649	1,659	0	1,659	2,150	0	2,150
Biomass/Biogas	166	0	166	166	0	166	166	0	166
Distributed Solar	0	304	304	0	304	304	0	290	290
Net Dependable Gas Capacity not Retained	0	0	0	0	0	0	0	0	0
<b>Totals</b>	59,280	14,727	74,007	75,610	31,351	106,963	60,156	12,679	72,836

The portfolios that RESOLVE generates are at the zonal level. As a result, the portfolios have to be mapped to the busbar level for use in the ISO transmission planning process. The resource-to-busbar mapping process is documented in the CPUC report entitled Methodology for Resource-to-Busbar Mapping & Assumptions for the Annual TPP dated September 2024 with updates for the 2025-2026 Transmission Planning Process. Figure F.2-1 shows a flowchart of the CPUC busbar mapping process.

Figure F.2-1: Flowchart of the Busbar Mapping Process

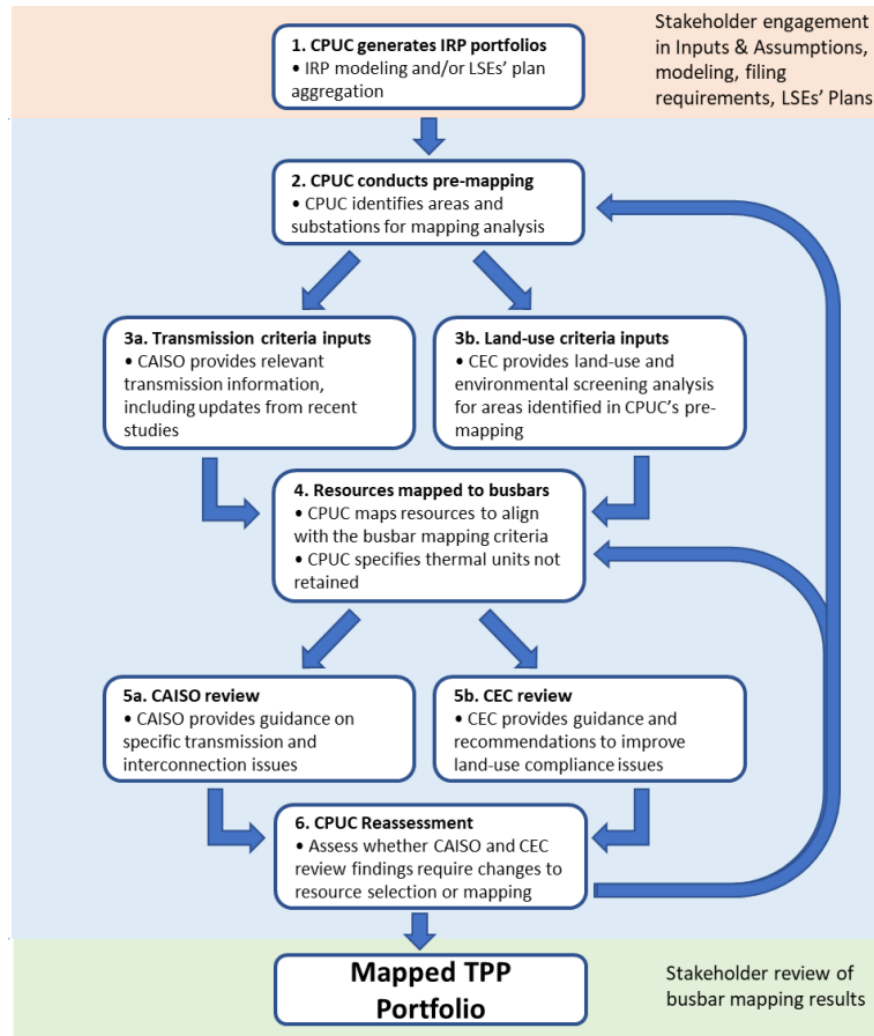

The portfolio resources were modeled in the ISO studies in accordance with the results of the mapping process. Figure F.2-2 below identifies the interconnection areas and the capacities of the resources in the CPUC’s base and sensitivity portfolios. The resource types within each interconnection area and the mapping of the resources are provided in the individual interconnection area sections below.

Figure F.2-2: Base and Sensitivity Portfolios Total MW in each Interconnection Area

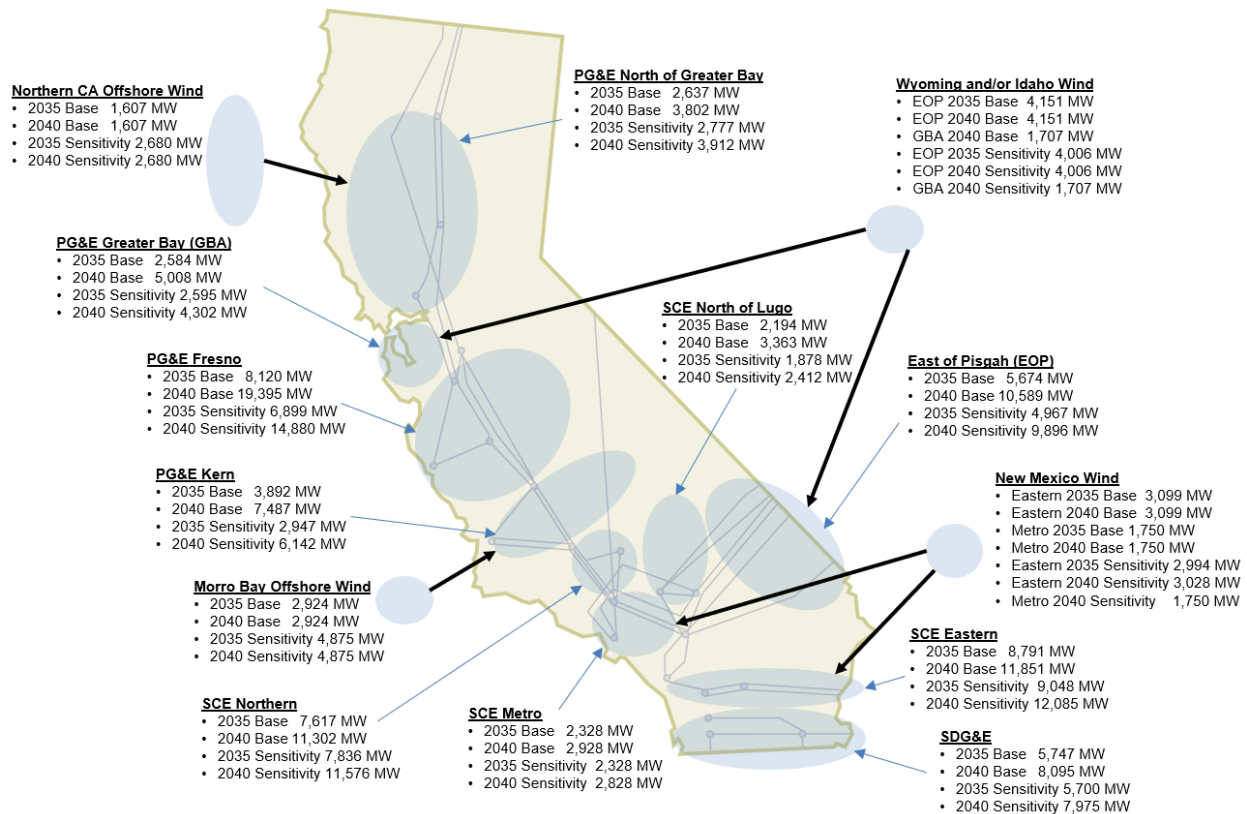

### F.2.1. Approved Non-CPUC Jurisdictional Integrated Resource Plans

As a continued effort to coordinate with the non-CPUC jurisdictional entities to incorporate their approved IRP into the ISO TPP, the ISO sent out a non-CPUC jurisdictional IRP resource mapping workbook to the entities to gather their integrated resource planning information on October 30, 2024. By January 15, 2025, the ISO received data submittals and approved IRP documents from the following Publicly Owned Utilities (POUs): Anaheim Public Utilities (APU), Riverside Public Utilities (RPU), Pasadena Water and Power (PWP), Vernon Public Utilities (VPU), Northern California Power Agency (NCPA), Silicon Valley Power (SVP), Colton Electric Utility (CEU) and Valley Electric Association (VEA).

All non-CPUC jurisdictional resource data provided that was in an approved IRP or a document approved by their senior leadership was included in the models for the TPP analysis. However, the resource portfolios provided by the CPUC based on the CPUC IRP, already include placeholder resources to meet the POU load. In many cases the exact same resources have already been modeled, so those resources were transferred from the CPUC portfolio to the non-CPUC jurisdictional portfolio. Some non-CPUC jurisdictions also identified certain amounts and types of generic resources the entities planned to procure, but no specific projects or substations were identified. For those generic

resources, the ISO transferred the same amounts and types of resources from CPUC generic portfolio to the non-CPUC jurisdictional portfolio. In cases where no CPUC portfolio was mapped to the same or nearby locations, the ISO transferred CPUC resources at locations that are behind the same constraints to the POU portfolio.

Table F.2-2: Additional non-CPUC jurisdictional portfolio resources modeled in the study

Substation	Resource Type	2035 Baseline Portfolio			2040 Baseline Portfolio			2035 Sensitivity Portfolio		
		FCDS (MW)	EO (MW)	Total (MW)	EO (MW)	EO (MW)	Total (MW)	FCDS (MW)	EO (MW)	Total (MW)
Mira Loma	Li_Battery (4-hour)	300	-	300	150	-	150	300	-	300
Coso	Geothermal	10	-	10	10	-	10	10	-	10
Goodrich	Li_Battery (4-hour)	25	-	25	25	-	25	25	-	25
Red Bluff	Solar	-	78	78	-	78	78	-	78	78
Rector	Li_Battery (4-hour)	40	-	40	40	-	40	80	-	80
Bellota	Li_Battery (4-hour)	133	-	133	133	-	133	133	-	133
Ken-OKJ	Li_Battery (4-hour)	50	-	50	50	-	50	50	-	50
Vista	Li_Battery (4-hour)	35	-	35	18	-	18	35	-	35

### F.2.2. Transmission Capability Estimates and Utilization by Portfolios

One of the key inputs in the portfolio development and busbar mapping process is the transmission capability estimates provided by ISO. The transmission capability estimates limit the amount of FCDS and EODS resources that can be selected, without likely requiring transmission upgrades, in the part of the system that is affected by the constraint. The transmission capability estimates ISO published in a white paper on August 28, 2024 were used in the development of the resource portfolios for the current TPP.

The utilization of estimated available FCDS and EODS transmission capability by resource portfolios is monitored by the CPUC in the portfolio development process using RESOLVE and in the busbar mapping process using spreadsheet calculations. The results of the evaluation for the 2025-2026 TPP base portfolio based on the 2024 white paper are posted on the CPUC website.

Exceedances of actual transmission capability limits indicate a high likelihood of the need for transmission upgrades or other mitigation solutions for the delivery of portfolio resources behind the constraints, which the CPUC takes into account in the development and mapping of the resource portfolios. However, the spreadsheet analysis should not be viewed as a substitute for the analysis the ISO performed as part of this policy-driven assessment using detailed power system models.

### F.2.3. Additional Guidance from CPUC regarding the Portfolios

In the Modeling Assumptions for the 2025-2026 Transmission Planning Process, CPUC staff provide the additional guidance below on the base and sensitivity portfolios. The ISO has considered this guidance when conducting the policy-driven assessment.

#### Alignment with ISO Queue Resources with Allocated TPD

As was done for previous TPP cycles, CPUC staff requested that the that ISO continue the necessary studies to inform and enable opportunities to provide Maximum Import Capability (MIC) expansion and the development of incremental transmission capacity to support the OOS and long-lead time (LLT) resources mapped in the base portfolio, while preserving the existing transmission capacity that has been allocated to other projects earlier in the interconnection queue. CPUC Working Group staff sought to align the mapping with resources in the ISO's interconnection queue that have been assigned transmission plan deliverability (TPD) while still aligning with the various other busbar mapping criteria. To that end, not all the assigned TPD in the transmission areas key to OOS and LLT resources were accounted for by mapped resources. CPUC staff compiled the MW amounts and locations of these TPD allocated resources as shown in Table F.2-3 and Table F.2-4 so that the ISO can include them in addition to the mapped portfolio resources when conducting TPP analysis. Minor adjustments were also made to account for additional in-development resources identified by PTOs as shown in Table F.2-5.

Table F.2-3: Unaccounted TPD in key MIC regions

				TPD in key MIC regions unaccounted for by mapped resources (MWs)		
ISO Study Area	Substation	Voltage	Resource Type	2035 Base	2040 Base	2035 Sensitivity
SCE Eastern	Alberhill	500	Li_Battery	500	500	500
SCE Eastern	Cielo Azul	500	Li_Battery	638	388	638
SCE Eastern	Colorado River	230	Li_Battery	300	150	300
SCE Eastern	Delaney	500	Li_Battery	450	350	450
SCE Eastern	Devers	230	Li_Battery	146	66	146
SCE Eastern	Etiwanda	230	Li_Battery	400	400	515
SCE Eastern	Red Bluff	230	Li_Battery	810	810	810
SCE Eastern	Red Bluff	500	Li_Battery	500	430	500
SCE Eastern	Valley (SCE)	500	Li_Battery	710	710	810
SDG&E	Hassayampa	500	Li_Battery	25	-	25
SDG&E	Imperial Valley	230	Li_Battery	100	-	100
SDG&E	Escondido	69	Li_Battery	33	-	33
SDG&E	El Cajon	69	Li_Battery	50	50	50
East of Pisgah	Gamebird	230	Li_Battery	137	-	150
East of Pisgah	Desert View	230	Li_Battery	350	100	350
East of Pisgah	Innovation	230	Li_Battery	100	-	150
East of Pisgah	Trout Canyon	230	Li_Battery	864	550	942
East of Pisgah	Valley (VEA)	230	Li_Battery	40	-	40
East of Pisgah	Eldorado	230	Li_Battery	250	-	250
East of Pisgah	Mohave	500	Li_Battery	920	780	1,015
Total				<b>7,323</b>	<b>5,283</b>	<b>7,773</b>

Table F.2-4: Unaccounted TPD impacting Offshore Wind deliverability

				TPD at key buses for North Coast OSW unaccounted for by mapped resources (MWs)		
ISO Study Area	Substation	Voltage	Resource Type	2035 Base	2040 Base	2035 Sensitivity
PG&E GBA	Birds Landing	230	Li_Battery	50	-	65
PG&E GBA	Cooley Landing	60	Li_Battery	65	50	65
PG&E NGBA	Cortina	115	Li_Battery	116	76	116
PG&E GBA	Kirker	115	Li_Battery	2	2	2
PG&E GBA	Martin	115	Li_Battery	312	162	312
PG&E GBA	Pittsburg	115	Li_Battery	675	500	325
PG&E GBA	Pittsburg	230	Li_Battery	325	250	575
PG&E NGBA	Tulucay	60	Li_Battery	2	2	2
Total				<b>1,547</b>	<b>1,042</b>	<b>1,462</b>

Table F.2-5: Adjustments to the portfolio to account additional in-development resources identified

ISO Study Area	Substation	Voltage	Resource Type	2035 Base (MW)	2040 Base (MW)	2035 Sensitivity (MW)
SCE Northern	Windhub	500	Li_Battery	657	577	657
SCE Northern	Whirlwind	230	Li_Battery	40	20	40
SCE Northern	Whirlwind	230	LDES	100	100	-
SCE Northern	Moorpark	230	Li_Battery	75	75	75
SCE NOL	Roadway	115	Li_Battery	40	40	50
SCE Eastern	Red Bluff	500	Li_Battery	50	60	50
SCE Metro	Walnut	220	Li_Battery	200	200	200
SCE Metro	Mira Loma	230	Li_Battery	58	29	58
SDG&E	Escondido	69	Li_Battery	-	16.5	-
SDG&E	Imperial Valley	230	Li_Battery	-	50	-
SDG&E	Talega	138	Li_Battery	100	50	100
PG&E NGBA	Lakeville	115	Li_Battery	250	250	250
PG&E GBA	Tesla	230	Li_Battery	175	175	175
PG&E Fresno	Gates	500	Li_Battery	40	40	40
Total				<b>1,785</b>	<b>1,673</b>	<b>1,695</b>

### Additional Analysis of Transmission Needs for Out-of-state and In-state Wind on New Out-of-ISO Transmission

The 2025-2026 TPP has a significant amount of OOS wind on new transmission in both the 2035 and 2040 model years (9,000 MW and 10,707 MW, respectively). This amount of OOS wind and the potential transmission solutions have not been studied at a detailed level. Only high-level approximate solutions have been identified in the ISO’s two 20-year Transmission Outlooks. The potential transmission solutions are likely to be large, complex and crossing difficult terrain and multiple BAAs. Additionally, the interconnection points for these resources assumed in the mapping are based only on high-level studies and more optimal and cost-effective alternatives may exist. Due to these uncertainties, CPUC staff recommend the ISO conduct additional analysis but defer approving any of the potential transmission lines needed for these resources in the 2025-2026 TPP. In specific, this request refers to the 1,500 MW Wyoming wind mapped to Eldorado 500 kV not utilizing the TransWest line in 2035 and 2040 portfolios, 1,750 MW New Mexico wind mapped to Lugo 500 kV in 2035 and 2040 portfolios, and 1,707 MW of Wyoming wind mapped to Tesla 500 kV in the 2040 portfolio.

In addition, the portfolio has 1,150 MW of in-state wind mapped to the area of Northern California serviced by NVE transmission system in both 2035 and 2040. Northern California Wind was evaluated as part of the 2024-2025 TPP. The amount of generation currently mapped will be able to be supported through existing transmission, however significant

increases to the generation may require additional transmission to deliver the generation to the ISO system.

To evaluate the impact and identify in-ISO transmission needs to accommodate the additional OOS wind resources in this TPP's policy study, the additional OOS wind resources listed above were not modeled in the 2035 and 2040 base portfolio analysis, instead, a 2040 OOS wind sensitivity study was conducted with all these resources modeled at the interconnection points assumed in the mapping.

### Out-of-ISO Resources and Maximum Import Capability (MIC)

The 2025-2026 TPP base case portfolio, in addition to the over 10,700 MW of OOS wind on new transmission by 2040, has a significant amount of geothermal mapped to IID and areas in Nevada and Utah beyond the ISO's Balancing Area. As was done for the 2024-2025 TPP portfolio, busbar Working Group staff specified in the Mapping Dashboard the out-of-ISO transmission and MIC assumptions for these resources including whether the resources should be treated by the ISO in TPP analysis as using existing MIC allocations or require MIC expansion. For all the OOS wind on new transmission and geothermal resources, Working Group staff identified the resources as requiring MIC expansion. The ISO staff consulted with CPUC staff when considering alternative locations for these imports if the identified locations were not feasible or the ISO identified better alternative intertie points.

### Battery Storage-Specific Transmission Upgrades and Battery Storage as Transmission Upgrade Alternatives

Battery mappings are relatively flexible and accordingly the CPUC asked the ISO to consult with CPUC staff before moving forward with any new policy-driven transmission upgrades associated specifically with storage mapping in this planning cycle.

## F.3. Review of Previously Approved Projects with substantial changes

### Eagle Rock-Fulton-Silverado 115 kV Line Reconductoring Project

The following reductions in scope are made to this project that was approved in the 2024-2025 TPP. These changes are based on the needs identified in the 2025-2026 on-peak deliverability assessment:

- Reconductor the North-South (N/S) section of line from Eagle-Rock to structure 004/023 with 954 ACSS conductor (~8 miles).

- Leave Eagle Rock substation terminal unchanged (rated 1,600 Amps).
- Leave as-is the Bundled 2300 AAC section from structure 004/023 to Structure 020/087A (rated 2,964 amps SE).
- Leave as-is the East-West (E/W) section between Fulton and Silverado as 477 ACSS (rated 1,144 amps SE).

The updated project cost is \$70M - \$140M and expected ISD is 2034.

### Tesla –Newark #2 230 kV Line Reconductoring Project

This project was approved in the 2023-2024 TPP cycle. The original scope included reconductoring the Tesla –Newark #2 230 kV line - From 024/148 to Newark (approximately 4.28 miles) with 954 ACSS conductor. The revised scope will now reconductor this section with 1113 ACSS conductor. This upgrade will not result in any increase in estimated cost.

### Lugo–Victor–Kramer 230 kV upgrades

These projects were approved in the 2022-2023 TPP to address the Lugo–Victor–Kramer deliverability constraints, which affect deliverability of capacity resources in the NOL area due to thermal overloading of the 500/230 kV and 230/115 kV transformers as well as 230 kV and 115 kV lines in the area under contingency conditions. Deliverability of resources located north of Victor is also limited by voltage instability and thermal overloading due to the category P7 contingency of Kramer–Victor 230 kV #1 & #2 lines.

The total cost of these projects is \$482 million and includes:

- A 3rd Lugo 500/230 kV transformer (\$70 million);
- Reconductoring Lugo–Victor 230 kV No. 1, 2, 3 & 4 lines (\$112 million); and
- Rebuilding Kramer–Victor 115 kV lines for 230 kV operation and looping the old segment of Kramer–Victor 115 kV line into Roadway (\$300 million).

SCE has informed the ISO that the total estimated cost of these projects is now \$945 million.

The ISO evaluated two other alternatives with updated cost estimates provided by SCE.

Alternative 1: New Kramer-Lugo 500 kV line (\$1,585 - \$2,247 million):

- Construct new of 500 kV single circuit (new ROW) between Kramer and Lugo; and
- Construct new 500 kV substation at Kramer with two 500/230 kV transformers.

Alternative 2: New Coolwater-Lugo 230 kV line (\$1,571 - \$2,155 million):

- Construct new 34 miles of 220 kV double circuit (new ROW) – follow previously identified route between Coolwater and Calcite;
- Rebuild Calcite-Lugo:
  - Remove 33 miles of double circuit 220 kV;
  - Install new 33 miles of double circuit 220 kV between Calcite and Lugo; and
- Lugo 3AA Bank.

No other alternatives were identified that would address the identified transmission constraints. Since the previously approved project is the lowest cost option to meet the need, the Lugo–Victor–Kramer 230 kV upgrades continue to be needed.

### San Bernardino-Etiwanda No.1, San Bernardino-Vista No.1, Vista-Etiwanda No.1, Colorado River-Red Bluff No.1 500 kV line upgrades and Mira Loma-Mesa 500kV Underground Cable Addition

These projects were approved in the 2022-2023 TPP to address deliverability constraints, which affect deliverability of capacity resources in the Eastern SCE area due to thermal overloading of these lines in the area with all facilities in-service and under contingency conditions.

The transmission upgrades considered to address these overloads is to increase the rating of the following lines. The estimated cost at the time of approval shown along with the updated cost estimate provided by SCE in parenthesis:

- San Bernardino-Etiwanda No.1 230 kV line - \$65 million (\$95 million);
- Vista-Etiwanda No.1 230 kV line - \$13 million (\$66 million);
- San Bernardino-Vista No.1 230 kV line - \$18 million (\$37 million); and
- Colorado River-Red Bluff No.1 500 kV line - \$50 million (\$65 million).

In addition, a third underground cable is considered to be installed on the most limiting section of the existing Mira Loma-Mesa 500 kV circuit, increasing the rating of the section. The cost of this upgrade at the time of approval was \$35 million, and the latest cost estimate is \$70 million.

The resource portfolios continue to show the need for all of these existing system upgrades, and the incremental deliverability created by these upgrades has been fully allocated to generation projects progressing through the generation interconnection process. There have been no more cost effective alternatives identified.

### Del Amo - Mesa - Serrano 500 kV Project

This project was approved in the 2022-2023 TPP to address south of Mesa corridor constraints affecting the deliverability of capacity resources due to thermal overloading of the Mesa–Lighthipe and Mesa–Laguna Bell 230 kV lines and the Mesa 500/230 kV transformers. The project also addressed Serrano–Barre corridor constraints affecting deliverability of capacity resources due to thermal overloading of the Serrano 500/230 kV transformer and the 230 kV transmission lines between Serrano and Barre substations.

At the time of approval this alternative had a total cost estimate of \$1,125 million and consists of the following developments:

- A new Mesa-Serrano 500 kV line created by extending one of the existing box-looped segments of the Mesa–Mira Loma 500 kV line to Serrano;
- Build 500 kV facilities at Del Amo Substation complete with three 500/230 banks; construct two 500 kV lines to loop the new Mesa–Serrano 500 kV line into Del Amo Substation; and
- Loop Alamitos–Barre No. 1 and No. 2 230 kV lines into Del Amo Substation.

SCE has informed the ISO that the estimated cost of this project is now \$5000 million.

The ISO removed this project from the study model in this planning cycle to reevaluate the need for the project and to identify potential alternatives. In the Policy studies with the latest resource portfolios it was determined that the project is not needed to ensure deliverability of resources. This is because the latest resource portfolios have approximately 2000 MW of additional battery storage downstream from the previously identified line overloads that were driving the policy-driven need for this project. However, because of updated load forecasts showing higher load growth, the removal of this project from the ISO transmission system models did cause reliability concerns. These reliability concerns are addressed in Appendix B and Chapter 2.

## F.4. On-Peak Deliverability Assessment

The primary objective of the policy-driven on-peak deliverability assessment is to support deliverability of the renewable generation and energy storage resources that are identified in the portfolios as requiring FCDS status so they can count towards meeting resource adequacy needs. The assessment evaluates whether the net resource output from a given area can be simultaneously transferred to the remainder of the ISO Control Area during periods of peak system load. The on-peak deliverability assessment of the base and sensitivity portfolios was performed in accordance with the on-peak deliverability assessment methodology.

### F.4.1. On-Peak Deliverability Assessment Assumptions

The deliverability assessment is performed under two distinct system conditions – the highest system need (HSN) scenario and the secondary system need (SSN) scenario. The HSN scenario represents the period when the capacity shortage is most likely to occur. In this scenario, the system reaches peak sale with low solar output. The highest system need hours represent the hours ending 19 to 22 in the summer months.

The secondary system need scenario represents the period when capacity shortage risk increases if variable resources are not deliverable during periods when the system depends on their high output for resource adequacy. In this scenario, the system load is modeled to represent the peak consumption level and solar output is modeled at a significantly higher output. The secondary system need hours are hours ending 15 to 18 in the summer months.

The ISO performed the on-peak deliverability assessment for both HSN and SSN scenarios. For each scenario and each portfolio, the ISO developed a master on-peak deliverability assessment base case from which area cases are derived. Key assumptions of the deliverability assessment are described below.

#### Transmission

The ISO modeled the same transmission system as in the 2035 and 2040 peak load base cases that are used in the reliability assessment performed as part of the current transmission planning process.

#### System load

The ISO modeled the coincident 1-in-5 year peak for the ISO balancing authority area load in the HSN base case. Pump load was dispatched within the expected range for summer

peak load hours. The load in the SSN base case was adjusted from HSN to represent the net customer load at the time of forecasted peak consumption.

Maximum resource output (Pmax) assumptions

Pmax in the on-peak deliverability assessment represents the resource-type specific maximum resource output assumed in the deliverability assessment. For existing non-intermittent generating units, the highest summer month NQC in the last three years is used as Pmax. For proposed FCDS non-intermittent generators that do not have NQC, the Pmax is set according to the interconnection request. For non-intermittent generic portfolio resources, the FCDS capacity provided in the portfolio is used as the Pmax. For FCDS energy storage resources, the Pmax in the HSN scenario is set to the 4-hour discharging capacity, limited by the requested maximum output from the generator. Pmax for energy storage in the SSN scenario is set at half of the HSN value. For hybrid projects, the study amount for each technology is first calculated separately. Then the total study amount among all technologies is based on the sum of each technology, but limited by the requested maximum output of the generation project.

FCDS intermittent resources are modeled in the HSN scenario based on the output profiles during the highest system need hours with low unloaded capacity levels. A 20% exceedance production level for wind and solar resources during these hours sets the Pmax tested in the HSN deliverability assessment. In the SSN scenario, intermittent resources are modeled based on the output profiles during the secondary system need hours with low unloaded capacity levels. 50% exceedance production level for wind and solar resources during those hours sets the Pmax tested in the SSN deliverability assessment.

The maximum resource output (Pmax) assumptions used in the HSN and SSN deliverability assessment for FCDS resources are shown in Table F.4-1. For resources with partial deliverability status (PCDS), the Pmax amounts in the table are derated by the deliverable percentage.

*Table F.4-1: Maximum FCDS resource output tested in the deliverability assessment*

	HSN				SSN			
	SDG&E	SCE	PG&E	VEA	SDG&E	SCE	PG&E	VEA
Solar	6%	13%	15%	8%	71%	80%	71%	66%
Wind	35%	48%	50%	48%	10%	17%	19%	17%
Out-of-State Wind	67%				35%			
Off-Shore Wind	83%				45%			

Energy Storage	100% or 4-hour equivalent if duration is < 4-hour	50% or 4-hour equivalent if duration is < 4-hour
Non-Intermittent resources	NQC or 100%	

Import Levels

For the HSN scenario, the net scheduled imports at all branch groups as determined in the latest annual Maximum Import Capability (MIC) assessment set the base import targets in the study. Approved MIC expansions will be added to the import levels. Historically unused Existing Transmission Contracts (ETC’s) crossing control area boundaries were modeled as zero MW injections at the tie point, but available to be turned on at remaining contract amounts for screening analysis. MIC expansions needed to accommodate portfolio resources outside the ISO BAA are added to the import targets. Valid MIC expansion requests are similarly modeled but are not allowed to trigger transmission upgrades.

For the SSN scenario, the hour with the highest total net imports among all secondary system need hours from the latest MIC assessment data is selected. Net scheduled imports for the hour set the import targets in the study. Approved and requested MIC expansions and MIC expansions needed to accommodate portfolio resources outside the ISO BAA are modeled similar to the HSN scenario.

**F.4.2. General On-Peak deliverability assessment procedure**

The main steps of the California ISO on-peak deliverability assessment procedure are described below.

Screening for Potential Deliverability Problems Using DC Power Flow Tool

A DC transfer capability/contingency analysis tool is used to identify potential deliverability problems. For each analyzed facility, an electrical circle is drawn which includes all generating units including unused Existing Transmission Contract (ETC) injections that have a 5% (or 10% for 500 kV lines) or greater:

- Distribution factor (DFAX) = ( $\Delta$  flow on the analyzed facility /  $\Delta$  output of the generating unit) \*100%; or
- Flow impact = (DFAX \* Full Study Amount / Applicable rating of the analyzed facility) \*100%.

Load flow simulations are performed, which study the worst-case combination of generator output within each 5%/10% Circle.

### Verifying and Refining the Analysis Using AC Power Flow Tool

The outputs of capacity units in the 5%/10% Circle are increased starting with units with the largest impact on the transmission facility. No more than 20 units are increased to their maximum output. In addition, no more than 1,500 MW of generation is increased. All remaining generation within the Control Area is proportionally displaced, to maintain a load and resource balance.

When the 20 units with the highest impact on the facility can be increased more than 1,500 MW, the impact of the remaining amount of generation to be increased is considered using a Facility Loading Adder. The Facility Loading Adder is calculated by taking the remaining MW amount available from the 20 units with the highest impact multiplied by the DFAX of each unit. An equivalent MW amount of generation with negative DFAX is also included in the Facility Loading Adder, up to 20 units. Negative Facility Loading Adders should be set to zero.

The ISO's on-peak deliverability assessment simulation procedure as implemented in PowerGem's Transmission Adequacy & Reliability Assessment (TARA) software was used to perform the policy-driven on-peak deliverability assessment.

On-peak deliverability assessment for the 2035 and 2040 base portfolios and 2035 LLT sensitivity portfolio were performed for both southern and northern California.

Potential mitigation options considered to address on-peak deliverability constraints include Remedial Action Schemes (RAS), reduction of energy storage behind the constraints, grid enhancing technology and transmission upgrades. Transmission upgrades identified for the base portfolio HSN scenario are recommended as policy driven upgrades. Transmission upgrades identified for the base portfolio SSN scenario will go through a comprehensive economic, policy and reliability benefit analysis to be considered for approval as a policy driven or economic upgrade.

## F.5. Off-Peak Deliverability Assessment

The ISO modified its on-peak deliverability assessment to reflect the changing contribution of solar to meeting resource adequacy needs. Additional solar resources provide a much lower incremental resource adequacy benefit to the system than the initial solar resources, because their output profile ceases to align with the peak hour of demand on the transmission system which has shifted to later in the day due to the proliferation of behind-the-meter solar. As a result, there is a reduced need for transmission upgrades to support deliverability of additional solar resources for resource adequacy purposes. Generation developers have been relying on transmission upgrades required under the previous on-peak deliverability assessment methodology to ensure that generation would not be exposed to excessive curtailment due to transmission limitations. Therefore, the off-peak deliverability assessment methodology was developed to address renewable energy delivery during hours outside of the summer peak load period to ensure some minimal level of protection from otherwise potentially unlimited curtailment.

Accordingly, the key objectives of the policy-driven off-peak deliverability assessment are to:

- Identify transmission constraints that would cause excessive renewable curtailment in accordance with the off-peak deliverability methodology;
- Identify potential transmission upgrades and other solutions needed to relieve excessive renewable curtailment; and
- Select the constraints and the identified transmission upgrades as candidates for a more thorough evaluation using production cost simulation.

### F.5.1. Off-peak deliverability assessment methodology

The general system study conditions are intended to capture a reasonable scenario for the load, generation, and imports that stress the transmission system, but not coinciding with an oversupply situation. By examining the renewable curtailment data from 2018, a load level of about 55% to 60% of the summer peak load and an import level of about 6000 MW was selected for the off-peak deliverability assessment.

The production of wind and solar resources under the selected load and import conditions varies widely. The production duration curves for solar and wind were examined. The production level under which 90% of the annual energy was selected to set the outputs to be tested in the off-peak deliverability assessment. The dispatch of the remaining generation fleet is set by examining historical production associated with the selected

renewable production levels. The hydro dispatch is about 30% of the installed capacity and the thermal dispatch is about 15%. All energy storage facilities are assumed offline.

The dispatch assumptions discussed above apply to both full capacity and energy-only resources. However, depending on the amount of generation in the portfolio, it may be impossible to balance load and resources under such conditions with all portfolio generation dispatched. The dispatch assumptions are applied to all existing, under-construction and contracted generators first, then some portfolio generators if needed to balance load and resources. This establishes a system-wide dispatch base case or master base case that is the starting case for developing each of the study area base cases to be used in the off-peak deliverability assessments. Table F.5-1 summarizes the generation dispatch assumptions in the master base case.

*Table F.5-1: ISO System-Wide Generator Dispatch Assumptions*

	<b>Dispatch Level</b>
Wind	44%
Solar	68%
Battery Storage	0%
Hydro	30%
Thermal	15%

The off-peak deliverability assessment is performed for each study area separately. The study areas in general are the same as the reliability assessment areas in the generation interconnection studies.

Study area base cases are created from the system-wide dispatch base case. All generators in the study area, existing or future, are dispatched to a consistent output level. In order to capture local curtailment, the renewable dispatch is increased to the 90% energy level for the study area, which is higher than the system-wide 90% energy level. The study area 90% energy level was determined from representing individual plants in different areas. For out-of-state and off-shore wind, the dispatch values are based on data obtained from NREL for the PCM model.

If the renewables inside the study area are predominantly wind resources (more than 70% of total study area capacity), wind resource dispatch is increased as shown in Table F.5-2. All the solar resources in the wind pocket are dispatched at the system-wide level of 68%. If the renewables inside the study area are not predominantly wind resources, then the dispatch assumptions in Table F.5-3 are used. The dispatch assumptions for out-of-state and off-shore wind used in the current study are provided in Table F.5-4.

Table F.5-2: Local Area Solar and Wind Dispatch Assumptions in Wind Area

	Wind Dispatch Level	Solar Dispatch Level
<b>SDG&amp;E</b>	69%	68%
<b>SCE</b>	64%	
<b>PG&amp;E</b>	63%	

Table F.5-3: Local Area Solar and Wind Dispatch Assumptions in Solar Area

	Wind Dispatch Level	Solar Dispatch Level
<b>SDG&amp;E</b>	79%	44%
<b>SCE</b>	77%	
<b>PG&amp;E</b>	79%	

Table F.5-4: Additional Local Area Dispatch Assumptions

Resource	Dispatch Level
Offshore Wind	100%
New Mexico Wind	67%
Wyoming Wind	67%

As the generation dispatch increases inside the study area, the following resource adjustment can be performed to balance the loads and resources:

- Reduce new generation outside the study area (staying within the Path 26, 4000 MW north to south, and 3000 MW south to north limits);
- Reduce thermal generation inside the study area;
- Reduce imports; and
- Reduce thermal generation outside the study area.

Once each study area case has been developed, a contingency analysis is performed for normal conditions and selected contingencies:

- Normal conditions (P0);
- Single contingency of transmission circuit (P1.2), transformer (P1.3), single pole of DC lines (P1.5) and two poles of PDCI if impacting the study area; and

- Multiple contingency of two adjacent circuits on common structures (P7.1) and loss of a bipolar DC line (P7.2).

For overloads identified under such dispatch, resources that can be re-dispatched to relieve the overloads are adjusted to determine if the overload can be mitigated:

- Existing energy storage resources are dispatched to their full four-hour charging capacity to relieve the overload;
- Thermal generators contributing to the overloads are turned off; and
- Imports contributing to the overloads are reduced to the level required to support out-of-state renewables in the RPS portfolios.

The remaining overloads after the re-dispatch will be mitigated by the identification of transmission upgrades or other solutions. Generators with 5% or higher distribution factor (DFAX) on the constraint are considered contributing generators. The distribution factor is the percentage of a particular generation unit's incremental increase in output that flows on a particular transmission line or transformer under the applicable contingency condition when the displaced generation is spread proportionally, across all dispatched resources available to scale down output proportionally. Generation units are scaled down in proportion to the dispatch level of the unit.

Off-peak deliverability assessment for the 2040 base portfolio was performed for both southern and northern California. The potential solutions considered to address off-peak deliverability constraints include Remedial Action Schemes (RAS), dispatching available battery storage behind the constraints, grid enhancing technology and transmission upgrades. Transmission upgrades identified to address off-peak deliverability constraints will be considered as candidates for a more thorough evaluation using production cost simulation.

## F.6. PG&E North of Greater Bay Interconnection Area

The total capacity of resources, by resource type, selected with Full Capacity Deliverability Status (FCDS) as well as those selected as Energy Only (EO) in the PG&E North of Greater Bay interconnection area are listed in Table F.6-1. The portfolios in the interconnection area are comprised of solar, wind (in-state and offshore), battery storage, geothermal, biomass/biogas and distributed solar resources. All portfolio resources are modeled in policy-driven assessments except in the on-peak deliverability assessment in which only FCDS resources are modeled.

Table F.6-1: PG&E North of Greater Bay Interconnection Area Base & Sensitivity Portfolios<sup>1</sup>

Resource Type	2035 Base Portfolio			2040 Base Portfolio			2035 Sensitivity Portfolio		
	FCDS (MW)	EO (MW)	Total (MW)	FCDS (MW)	EO (MW)	Total (MW)	FCDS (MW)	EO (MW)	Total (MW)
Solar	75	258	333	430	858	1,288	50	258	308
Wind – In State	1,705	98	1,803	1,705	98	1,803	1,298	42	1,340
Wind – Out-of-State	0	0	0	0	0	0	0	0	0
Wind - Offshore	1,607	0	1,607	1,607	0	1,607	2,680	0	2,680
Li Battery – 4 hr.	493	0	493	453	0	453	493	0	493
Li Battery – 8 hr.	95	0	95	305	0	305	95	0	95
Long Duration Energy Storage (LDES)	5	0	5	5	0	5	390	0	390
Geothermal	123	0	123	123	0	123	366	0	366
Biomass/Biogas	109	0	109	109	0	109	109	0	109
Distributed Solar	0	46	46	0	46	46	0	46	46
<b>Totals</b>	<b>4,212</b>	<b>402</b>	<b>4,614</b>	<b>4,737</b>	<b>1,002</b>	<b>5,739</b>	<b>5,481</b>	<b>346</b>	<b>5,827</b>

The resources as identified in the CPUC busbar mapping for the PG&E North of Greater Bay interconnection area are illustrated on the single-line diagrams in Figure F.6-1, Figure F.6-2 and Figure F.6-3.

<sup>1</sup> Numbers include the adjustments to the base portfolio made by CPUC staff in the North of Greater Bay Interconnection Area to account for allocated TPD, additional in-development resources identified and non-CPUC jurisdictional IRP plan resources.

Figure F.6-1: North of Greater Bay Interconnection Area – Mapped 2035 Base Portfolio

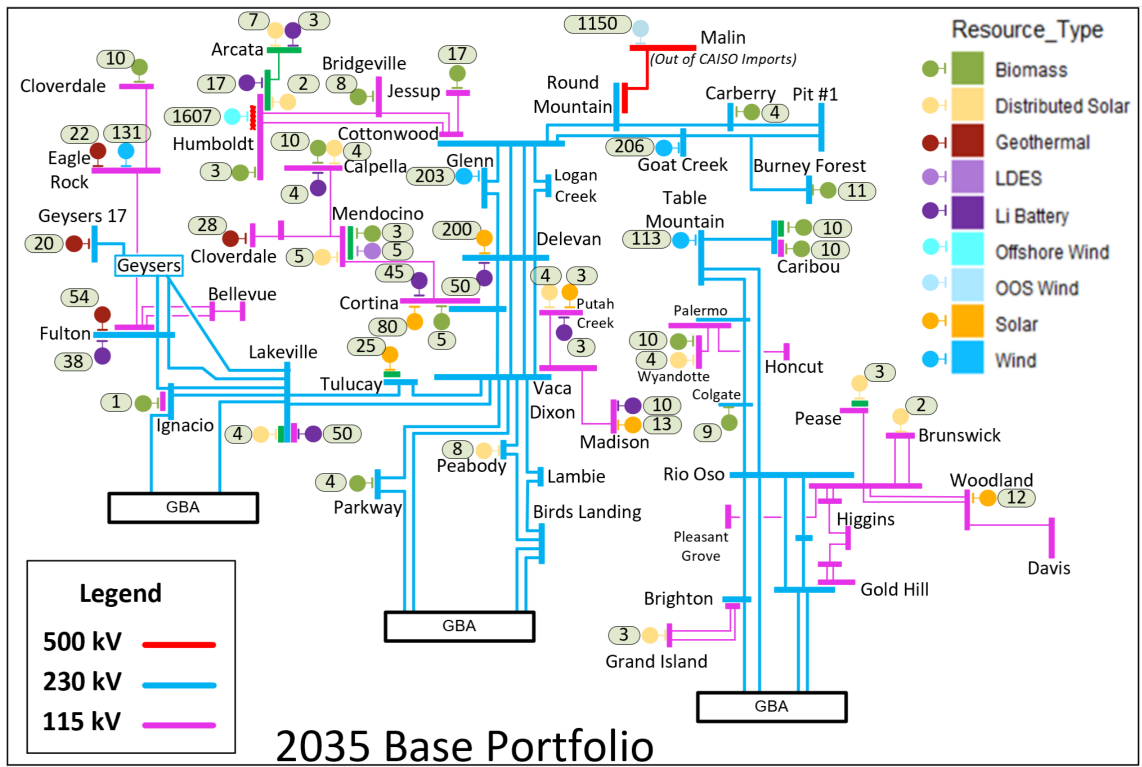

Figure F.6-2: North of Greater Bay Interconnection Area – Mapped 2040 Base Portfolio

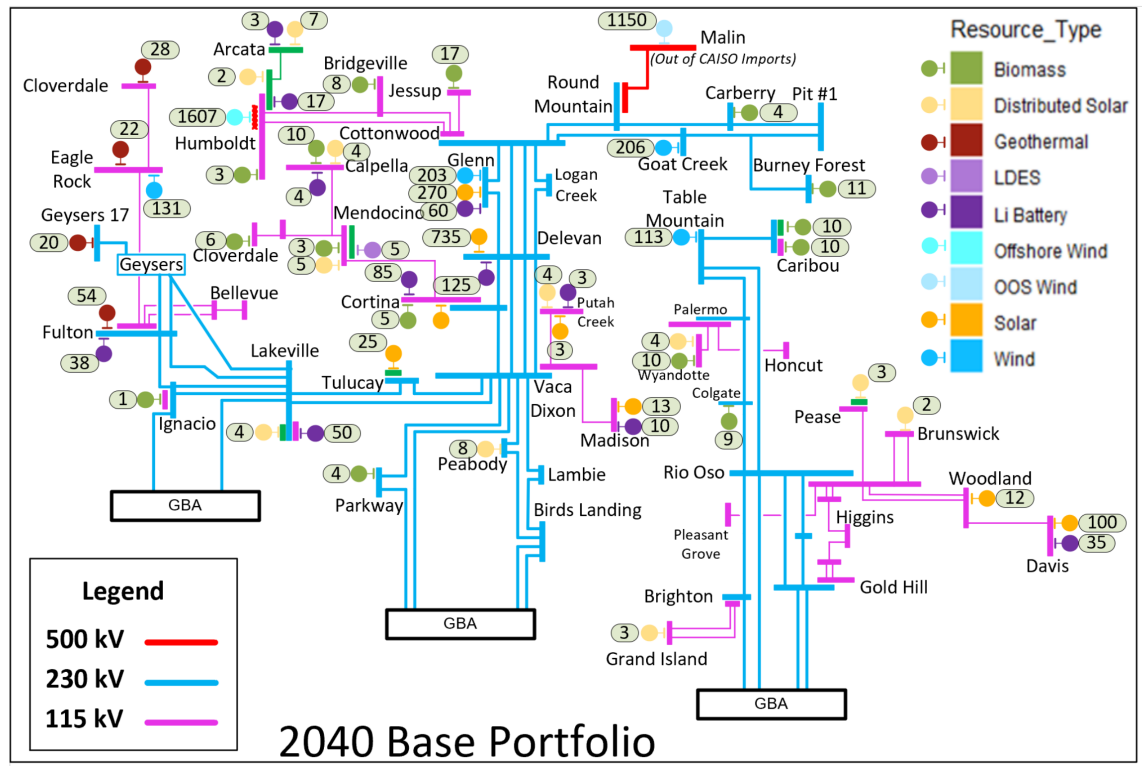
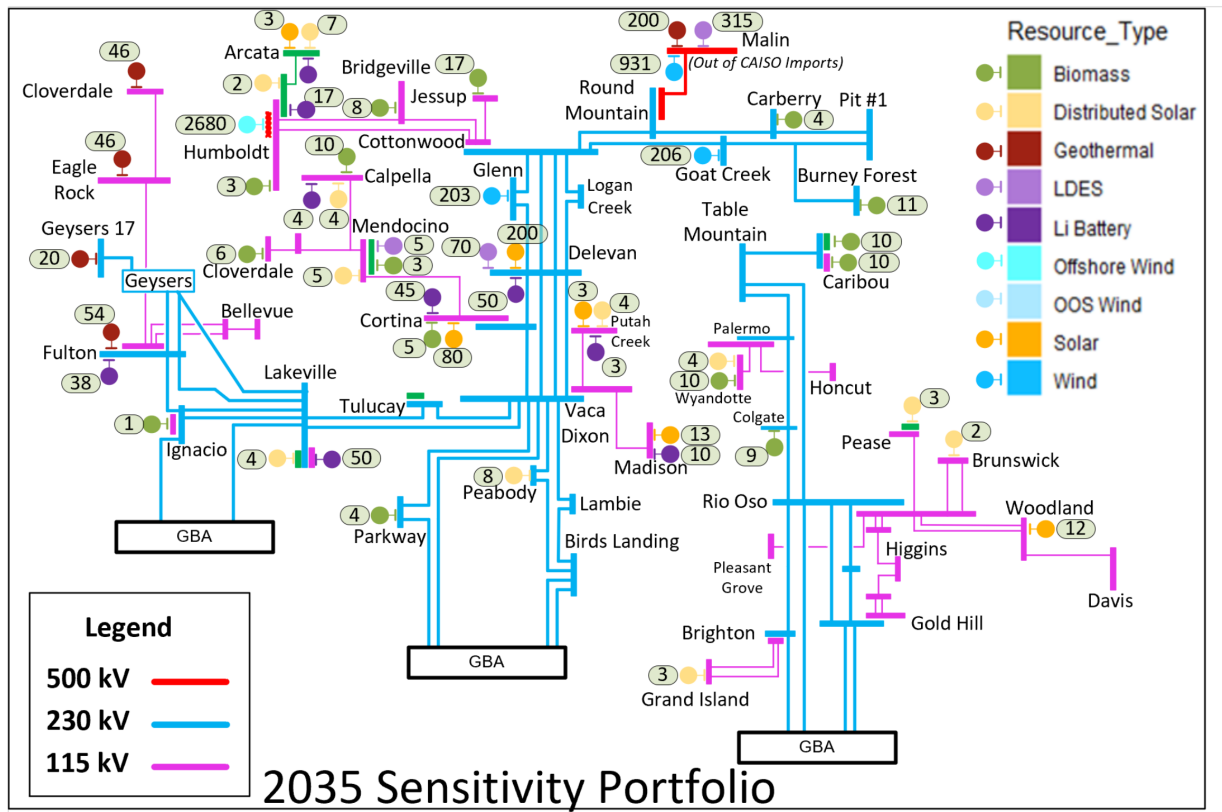

Figure F.6-3: North of Greater Bay Interconnection Area – Mapped 2035 Sensitivity Portfolio



### F.6.1. 2035 On-Peak Results

#### Hopland Bank 115/60 kV #2 on-peak deliverability constraint

The deliverability of renewable portfolio resources in the Northern California area is limited by thermal overloading of the Hopland Bank 115/60 kV #2 under NERC category P7 contingency as shown in Table F.6-2. This constraint was identified in baseline and sensitivity portfolios under HSN conditions. As shown in Table F.6-3, 1 MW of renewable and energy storage would be deliverable without any transmission upgrades. The constraint can be mitigated by a planned PG&E maintenance project.

Table F.6-2: Hopland Bank 115.60 kV #2 on-peak deliverability constraint

Overloaded Facility	Contingency	Scenario	Loading	
			Base	Sensitivity
Hopland Bank 115/60 NO.2	Geysers #9-Lakeville & Eagle Rock-Fulton-Silverado Lines	HSN	150.77%	158.27%

Table F.6-3: Hopland Bank 115/60 kV #2 on-peak deliverability constraint summary

Affected transmission zones		North of Greater Bay Area	
		Base	Sensitivity
Portfolio resources behind the constraint (Installed FCDS capacity)		205	154
Generic portfolio battery storage behind the constraint (Installed FCDS capacity)		0	0
Deliverable portfolio resources w/o mitigation (Installed FCDS capacity)		1	0
Total undeliverable baseline and portfolio resources (Installed FCDS capacity)		613	579
Mitigation Options	RAS	N/A	
	Reduce generic battery storage (MW)	N/A	
	Transmission upgrade including cost	N/A	
Recommended Mitigation		PG&E maintenance project	

### Humboldt - Bridgeville 115 kV on-peak deliverability constraint

The deliverability of renewable portfolio resources in the Northern California area is limited by thermal overloading of the Humboldt - Bridgeville 115 kV line under NERC category P1 contingency as shown in Table F.6-4. This constraint was identified in sensitivity portfolio under HSN conditions. As shown in Table F.6-5, 0 MW of renewable and energy storage would be deliverable without any transmission upgrades. The constraint is identified only in the sensitivity scenario and does not need mitigation.

Table F.6-4: Humboldt - Bridgeville 115 kV line on-peak deliverability constraint

Overloaded Facility	Contingency	Scenario	Loading	
			Base	Sensitivity
Humboldt - Bridgeville 115 kV Line	Humboldt OSW-Collinsville 500kV	HSN	<100%	102.32%

Table F.6-5: Humboldt - Bridgeville 115 kV line on-peak deliverability constraint summary

Affected transmission zones		North of Greater Bay Area	
		Base	Sensitivity
Portfolio resources behind the constraint (Installed FCDS capacity)		N/A	2.5
Generic portfolio battery storage behind the constraint (Installed FCDS capacity)		N/A	0
Deliverable portfolio resources w/o mitigation (Installed FCDS capacity)		N/A	0
Total undeliverable baseline and portfolio resources (Installed FCDS capacity)		N/A	15
Mitigation Options	RAS	N/A	N/A

	Reduce generic battery storage (MW)	N/A	N/A
	Transmission upgrade including cost	N/A	N/A
Recommended Mitigation		N/A	Sensitivity Only

Ukiah-Hopland-Cloverdale 115 kV (Ukiah sub 115kv to Hopland Jct 115kv) on-peak deliverability constraint

The deliverability of renewable portfolio resources in the Northern California area is limited by thermal overloading of the Ukiah-Hopland-Cloverdale 115 kV (Ukiah sub 115kv to Hopland Jct 115kv) line under NERC category P7 contingencies as shown in Table F.6-6. This constraint was identified in baseline and sensitivity portfolio under HSN conditions. As shown in Table F.6-7, 0 MW of renewable and energy storage would be deliverable without any transmission upgrades. This constraint is currently an identified LDNU and will be addressed through the generator interconnection process.

*Table F.6-6: Ukiah-Hopland-Cloverdale 115 kV (Ukiah sub 115kV to Hopland Jct 115kV) line on-peak deliverability constraint*

Overloaded Facility	Contingency	Scenario	Loading	
			Base	Sensitivity
Ukiah-Hopland-Cloverdale 115 kV (Ukiah sub 115kV to Hopland Jct 115kV)	Eagle Rock -Redbud & Cortina-Mendocino #1 Lines	HSN	118.85%	<100%
	Geysers #3-Eagle Rock & Geysers #7-Eagle Rock Lines		<100%	128.81%

*Table F.6-7: Ukiah-Hopland-Cloverdale 115 kV (Ukiah sub 115kv to Hopland Jct 115kv) line on-peak deliverability constraint summary*

Affected transmission zones		North of Greater Bay Area	
		Base	Sensitivity
Portfolio resources behind the constraint (Installed FCDS capacity)		195	105
Generic portfolio battery storage behind the constraint (Installed FCDS capacity)		0	0
Deliverable portfolio resources w/o mitigation (Installed FCDS capacity)		0	61
Total undeliverable baseline and portfolio resources (Installed FCDS capacity)		443	121
Mitigation Options	RAS	N/A	
	Reduce generic battery storage (MW)	N/A	
	Transmission upgrade including cost	N/A	
Recommended Mitigation		This constraint is a currently identified LDNU and will be addressed through the generator interconnection process	

Geyser # 3 - Cloverdale 115 kV (Cloverdale 115kV To MPE Tap115 kV) on-peak deliverability constraint

The deliverability of renewable portfolio resources in the Northern California area is limited by thermal overloading of the Geyser # 3 - Cloverdale 115 kV (Cloverdale 115kV To MPE Tap115 kV) line under NERC category P7 contingencies as shown in Table F.6-8. This constraint was identified in baseline and sensitivity portfolio under HSN conditions. As shown in Table F.6-9, 0 MW of renewable and energy storage would be deliverable without any transmission upgrades. This constraint is currently an identified LDNU and will be addressed through the generator interconnection process.

*Table F.6-8: Geyser # 3 - Cloverdale 115 kV (Cloverdale 115kV To MPE Tap115 kV) line on-peak deliverability constraint*

Overloaded Facility	Contingency	Scenario	Loading	
			Base	Sensitivity
Geyser # 3 - Cloverdale 115 kV (Cloverdale 115kV To MPE Tap115 kV)	Eagle Rock -Redbud & Cortina-Mendocino #1 Lines	HSN	114.57%	<100%
	Geysers #3-Eagle Rock & Geysers #7-Eagle Rock Lines		<100%	105.89%

*Table F.6-9: Geyser # 3 - Cloverdale 115 kV (Cloverdale 115kV To MPE Tap115 kV) line on-peak deliverability constraint summary*

Affected transmission zones		North of Greater Bay Area	
		Base	Sensitivity
Portfolio resources behind the constraint (Installed FCDS capacity)		166	53
Generic portfolio battery storage behind the constraint (Installed FCDS capacity)		0	0
Deliverable portfolio resources w/o mitigation (Installed FCDS capacity)		0	44
Total undeliverable baseline and portfolio resources (Installed FCDS capacity)		312	87
Mitigation Options	RAS	N/A	
	Reduce generic battery storage (MW)	N/A	
	Transmission upgrade including cost	N/A	
Recommended Mitigation		This constraint is a currently identified LDNU and will be addressed through the generator interconnection process	

Geyser #3 - Eagle Rock 115 kV line on-peak deliverability constraint

The deliverability of renewable portfolio resources in the Northern California area is limited by thermal overloading of the Geyser #3 - Eagle Rock 115 kV line under NERC category P7

contingency as shown in Table F.6-10. This constraint was identified in baseline and sensitivity portfolio under HSN conditions. As shown in Table F.6-11, 62 MW of renewable and energy storage would be deliverable without any transmission upgrades. This constraint is currently an identified LDNU and will be addressed through the generator interconnection process.

Table F.6-10: Geysers #3 - Eagle Rock 115 kV line on-peak deliverability constraint

Overloaded Facility	Contingency	Scenario	Loading	
			Base	Sensitivity
Geysers #3 - Eagle Rock 115 kV	Mendocino-Ukiah & Ukiah-Hopland-Cloverdale Lines	HSN	112.52%	127.48%

Table F.6-11: Geysers #3 - Eagle Rock 115 kV line on-peak deliverability constraint summary

Affected transmission zones		North of Greater Bay Area	
		Base	Sensitivity
Portfolio resources behind the constraint (Installed FCDS capacity)		92	115
Generic portfolio battery storage behind the constraint (Installed FCDS capacity)		0	0
Deliverable portfolio resources w/o mitigation (Installed FCDS capacity)		62	62
Total undeliverable baseline and portfolio resources (Installed FCDS capacity)		33	56
Mitigation Options	RAS	N/A	
	Reduce generic battery storage (MW)	N/A	
	Transmission upgrade including cost	N/A	
Recommended Mitigation		This constraint is a currently identified LDNU and will be addressed through the generator interconnection process	

Clear Lake - Eagle Rock 60 kV (Clear Lake 60 kV sub to Konocti Sub 60 kV) line on-peak deliverability constraint

The deliverability of renewable portfolio resources in the Northern California area is limited by thermal overloading of the Clear Lake - Eagle Rock 60 kV (Clear Lake 60 kV sub to Konocti Sub 60 kV) line under NERC category P1 as shown in Table F.6-12. This constraint was identified in baseline portfolio under HSN conditions. As shown in Table F.6-13, 185 MW of renewable and energy storage would be deliverable without any transmission upgrades. This is a local constraint and will be addressed through the generator interconnection process.

Table F.6-12: Clear Lake - Eagle Rock 60 kV (Clear Lake 60 kV sub to Konocti Sub 60 kV) line on-peak deliverability constraint

Overloaded Facility	Contingency	Scenario	Loading	
			Base	Sensitivity
Clear Lake - Eagle Rock 60 kV (Clear Lake 60 kV sub to Konocti Sub 60 kV)	Ukiah-Hopland-Cloverdale 115kV	HSN	100.16%	<100%

Table F.6-13: Clear Lake - Eagle Rock 60 kV (Clear Lake 60 kV sub to Konocti Sub 60 kV) line on-peak deliverability constraint summary

Affected transmission zones		North of Greater Bay Area	
		Base	Sensitivity
Portfolio resources behind the constraint (Installed FCDS capacity)		195	N/A
Generic portfolio battery storage behind the constraint (Installed FCDS capacity)		0	N/A
Deliverable portfolio resources w/o mitigation (Installed FCDS capacity)		185	N/A
Total undeliverable baseline and portfolio resources (Installed FCDS capacity)		10	N/A
Mitigation Options	RAS	N/A	N/A
	Reduce generic battery storage (MW)	N/A	N/A
	Transmission upgrade including cost	N/A	N/A
Recommended Mitigation		Local constraint, Will be addressed through the generator interconnection process	N/A

Lincoln - Pleasant Grove 115 kV Line on-peak deliverability constraint

The deliverability of renewable portfolio resources in the Northern California area is limited by thermal overloading of the Lincoln - Pleasant Grove 115 kV Line under NERC category P7 contingency as shown in Table F.6-14. This constraint was identified in baseline and sensitivity portfolio under HSN conditions. As shown in Table F.6-15, 0 MW of renewable and energy storage would be deliverable without any transmission upgrades. The constraint will be mitigated through a TPP reliability project.

Table F.6-14: Lincoln - Pleasant Grove 115 kV Line on-peak deliverability constraint

Overloaded Facility	Contingency	Scenario	Loading	
			Base	Sensitivity
Lincoln - Pleasant Grove 115 kV Line	Rio Oso-Atlantic 230 KV Line & Rio Oso-Gold Hill 230 KV Line	HSN	116.33%	118.92%

Table F.6-15: Lincoln - Pleasant Grove 115 kV Line on-peak deliverability constraint summary

Affected transmission zones		North of Greater Bay Area	
		Base	Sensitivity
Portfolio resources behind the constraint (Installed FCDS capacity)		16	16
Generic portfolio battery storage behind the constraint (Installed FCDS capacity)		0	0
Deliverable portfolio resources w/o mitigation (Installed FCDS capacity)		0	0
Total undeliverable baseline and portfolio resources (Installed FCDS capacity)		486	549
Mitigation Options	RAS	N/A	
	Reduce generic battery storage (MW)	N/A	
	Transmission upgrade including cost	N/A	
Recommended Mitigation		The constraint will be mitigated through a TPP reliability project.	

### Rio Oso - Atlantic 230 kV Line No. 1 on-peak deliverability constraint

The deliverability of renewable portfolio resources in the Northern California area is limited by thermal overloading of the Rio Oso - Atlantic 230 kV Line No. 1 under NERC category P1 contingency as shown in Table F.6-16. This constraint was identified in the sensitivity portfolio under HSN conditions. As shown in Table F.6-17, 0 MW of renewable and energy storage would be deliverable without any transmission upgrades. This constraint is identified only in the sensitivity scenario and does not need mitigation.

Table F.6-16: Rio Oso - Atlantic 230 kV Line No. 1 on-peak deliverability constraint

Overloaded Facility	Contingency	Scenario	Loading	
			Base	Sensitivity
Rio Oso - Atlantic 230 kV Line No. 1	Rio Oso-Gold Hill 230 kV	HSN	<100%	100.58%

Table F.6-17: Rio Oso - Atlantic 230 kV Line No. 1 on-peak deliverability constraint summary

Affected transmission zones		North of Greater Bay Area	
		Base	Sensitivity
Portfolio resources behind the constraint (Installed FCDS capacity)		N/A	16
Generic portfolio battery storage behind the constraint (Installed FCDS capacity)		N/A	0
Deliverable portfolio resources w/o mitigation (Installed FCDS capacity)		N/A	0
Total undeliverable baseline and portfolio resources (Installed FCDS capacity)		N/A	209
Mitigation Options	RAS	N/A	N/A

	Reduce generic battery storage (MW)	N/A	N/A
	Transmission upgrade including cost	N/A	N/A
Recommended Mitigation		N/A	Sensitivity only

Vaca - Bahia 230 kV Line on-peak deliverability constraint

The deliverability of renewable portfolio resources in the Northern California area is limited by thermal overloading of the Vaca - Bahia 230 kV Line under NERC category P7 contingency as shown in Table F.6-18. This constraint was identified in the sensitivity portfolio under HSN conditions. As shown in Table F.6-19, 353 MW of renewable and energy storage would be deliverable without any transmission upgrades. This constraint is identified only in the sensitivity scenario and does not need mitigation.

*Table F.6-18: Vaca - Bahia 230 kV Line on-peak deliverability constraint*

Overloaded Facility	Contingency	Scenario	Loading	
			Base	Sensitivity
Vaca - Bahia 230 kV Line	Birds-CC PP 230 KV and Birds-CC Sub 230 KV lines	HSN	<100%	101.57%

*Table F.6-19: Vaca - Bahia 230 kV Line on-peak deliverability constraint summary*

Affected transmission zones		North of Greater Bay Area	
		Base	Sensitivity
Portfolio resources behind the constraint (Installed FCDS capacity)		N/A	146
Generic portfolio battery storage behind the constraint (Installed FCDS capacity)		N/A	407
Deliverable portfolio resources w/o mitigation (Installed FCDS capacity)		N/A	353
Total undeliverable baseline and portfolio resources (Installed FCDS capacity)		N/A	213
Mitigation Options	RAS	N/A	N/A
	Reduce generic battery storage (MW)	N/A	N/A
	Transmission upgrade including cost	N/A	N/A
Recommended Mitigation		N/A	Sensitivity only

Vaca - Parkway 230 kV Line on-peak deliverability constraint

The deliverability of renewable portfolio resources in the Northern California area is limited by thermal overloading of the Vaca - Parkway 230 kV Line under NERC category P7 contingency as shown in Table F.6-20. This constraint was identified in the sensitivity

portfolio under HSN conditions. As shown in Table F.6-21, 410 MW of renewable and energy storage would be deliverable without any transmission upgrades. This constraint is identified only in the sensitivity scenario and does not need mitigation.

Table F.6-20: Vaca - Parkway 230 kV Line on-peak deliverability constraint

Overloaded Facility	Contingency	Scenario	Loading	
			Base	Sensitivity
Vaca - Parkway 230 kV	Birds-CC PP 230 KV and Birds-CC Sub 230 KV lines	HSN	<100%	100.65%

Table F.6-21: Vaca - Parkway 230 kV Line on-peak deliverability constraint summary

Affected transmission zones		North of Greater Bay Area	
		Base	Sensitivity
Portfolio resources behind the constraint (Installed FCDS capacity)		N/A	146
Generic portfolio battery storage behind the constraint (Installed FCDS capacity)		N/A	407
Deliverable portfolio resources w/o mitigation (Installed FCDS capacity)		N/A	410
Total undeliverable baseline and portfolio resources (Installed FCDS capacity)		N/A	156
Mitigation Options	RAS	N/A	N/A
	Reduce generic battery storage (MW)	N/A	N/A
	Transmission upgrade including cost	N/A	N/A
Recommended Mitigation		N/A	Sensitivity only

Birds Landing-Contra Costa Sub 230kV Line on-peak deliverability constraint

The deliverability of renewable portfolio resources in the Northern California area is limited by thermal overloading of the Birds Landing-Contra Costa Sub 230kV Line under NERC category P1 contingency as shown in Table F.6-22. This constraint was identified in the sensitivity portfolio under HSN conditions. As shown in Table F.6-23, 2361 MW of renewable and energy storage would be deliverable without any transmission upgrades. This constraint is identified only in the sensitivity scenario and does not need mitigation.

Table F.6-22: Birds Landing- Contra Costa Sub 230kV Line on-peak deliverability constraint

Overloaded Facility	Contingency	Scenario	Loading	
			Base	Sensitivity
Birds Landing-Contra Costa Sub 230kV Line	Birds-CC PP 230 KV	HSN	<100%	104.17%

Table F.6-23: Birds Landing- Contra Costa Sub 230kV Line on-peak deliverability constraint summary

Affected transmission zones		North of Greater Bay Area	
		Base	Sensitivity
Portfolio resources behind the constraint (Installed FCDS capacity)		N/A	3270
Generic portfolio battery storage behind the constraint (Installed FCDS capacity)		N/A	659
Deliverable portfolio resources w/o mitigation (Installed FCDS capacity)		N/A	2361
Total undeliverable baseline and portfolio resources (Installed FCDS capacity)		N/A	2794
Mitigation Options	RAS	N/A	N/A
	Reduce generic battery storage (MW)	N/A	N/A
	Transmission upgrade including cost	N/A	N/A
Recommended Mitigation		N/A	Sensitivity only

Birds Landing-Contra Costa PP 230kV Line on-peak deliverability constraint

The deliverability of renewable portfolio resources in the Northern California area is limited by thermal overloading of the Birds Landing-Contra Costa PPE 230kV Line under NERC category P1 contingency as shown in Table F.6-24. This constraint was identified in the sensitivity portfolio under HSN conditions. As shown in Table F.6-25, 1968 MW of renewable and energy storage would be deliverable without any transmission upgrades. This constraint is identified only in the sensitivity scenario and does not need mitigation.

Table F.6-24: Birds Landing-Contra Costa PPE 230kV Line on-peak deliverability constraint

Overloaded Facility	Contingency	Scenario	Loading	
			Base	Sensitivity
Birds Landing-Contra Costa PP 230kV Line	Birds Landing-Contra Costa Sub 230kV Line	HSN	<100%	106.22%

Table F.6-25: Birds Landing-Contra Costa PPE 230kV Line on-peak deliverability constraint summary

Affected transmission zones		North of Greater Bay Area	
		Base	Sensitivity
Portfolio resources behind the constraint (Installed FCDS capacity)		N/A	3270
Generic portfolio battery storage behind the constraint (Installed FCDS capacity)		N/A	659
Deliverable portfolio resources w/o mitigation (Installed FCDS capacity)		N/A	1968

Total undeliverable baseline and portfolio resources (Installed FCDS capacity)		N/A	3188
Mitigation Options	RAS	N/A	N/A
	Reduce generic battery storage (MW)	N/A	N/A
	Transmission upgrade including cost	N/A	N/A
Recommended Mitigation		N/A	Sensitivity only

Drum - Higgins 115 kV Line on-peak deliverability constraint

The deliverability of renewable portfolio resources in the Northern California area is limited by thermal overloading of the Drum - Higgins 115 kV Line under NERC category P7 contingency as shown in Table F.6-26. This constraint was identified in the baseline and sensitivity portfolio under HSN conditions. As shown in Table F.6-27, 0 MW of renewable and energy storage would be deliverable without any transmission upgrades. This constraint will be mitigated by the Drum-Higgins 115kV Line Reconductoring Project.

*Table F.6-26: Drum - Higgins 115 kV Line on-peak deliverability constraint*

Overloaded Facility	Contingency	Scenario	Loading	
			Base	Sensitivity
Drum - Higgins 115 kV Line	Rio Oso-Atlantic 230 kV Line & Rio Oso-Gold Hill 230 kV Line	HSN	125.88%	128.39%

*Table F.6-27: Drum - Higgins 115 kV Line on-peak deliverability constraint summary*

Affected transmission zones		North of Greater Bay Area	
		Base	Sensitivity
Portfolio resources behind the constraint (Installed FCDS capacity)		39	39
Generic portfolio battery storage behind the constraint (Installed FCDS capacity)		0	0
Deliverable portfolio resources w/o mitigation (Installed FCDS capacity)		0	0
Total undeliverable baseline and portfolio resources (Installed FCDS capacity)		72	169
Mitigation Options	RAS	N/A	
	Reduce generic battery storage (MW)	N/A	
	Transmission upgrade including cost	Drum-Higgins 115kV Line Reconductoring Project (\$154.19-\$308.37 M).	
Recommended Mitigation		Drum - Higgins 115kV Line Reconductoring Project	

## Drum – Higgins 115kV Line Reconductoring Project

To mitigate overloads identified in the baseline and sensitivity portfolio on-peak deliverability studies, the ISO is recommending for approval, the Drum – Higgins 115kV Line Reconductoring Project. The estimated project cost range is \$154.19-\$308.37 M, with an expected in-service date of 2034. The scope includes reconductoring the entire Drum – Higgins 115kV line (approximately 30 mile) to a minimum SN rating of 1714 Amps (341 MVA, 954ACSS). The project scope also includes updating the limiting components at the substations if necessary.

Figure F.6-4: Drum – Higgins 115kV Line Reconductoring Project

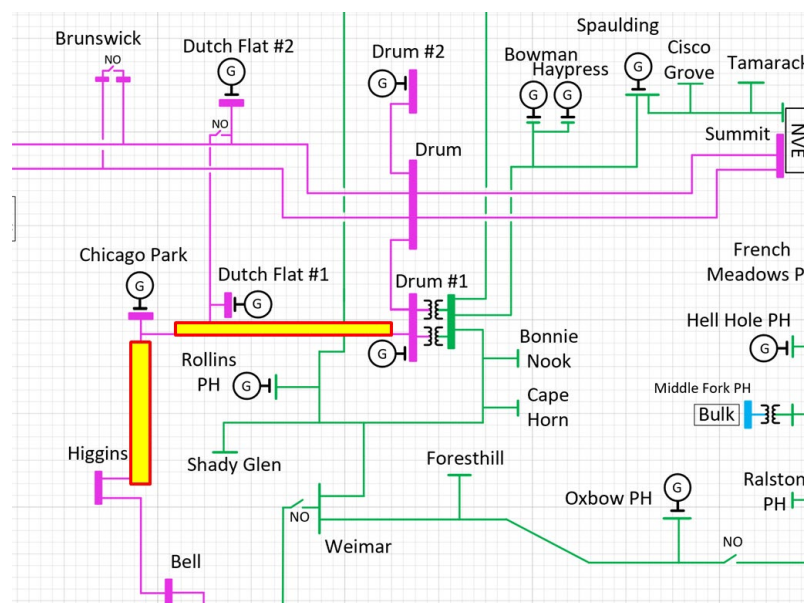

### F.6.2. 2040 On-Peak Results

#### Lakeville - Ignacio #2 230kV on-peak deliverability constraint

The deliverability of renewable portfolio resources in the Northern California area is limited by thermal overloading of the Lakeville - Ignacio #2 230kV under NERC category P7 contingency as shown in Table F.6-28. This constraint was identified in the baseline portfolio under HSN conditions. As shown in Table F.6-29, 0 MW of renewable and energy storage would be deliverable without any transmission upgrades. The ISO will continue to monitor this constraint.

Table F.6-28: Lakeville - Ignacio #2 230kV on-peak deliverability constraint

Overloaded Facility	Contingency	Base Portfolio Loading	
		HSN	SSN
Lakeville - Ignacio #2 230kV	Lakeville-Ignacio #1 & Lakeville-Sobrante #2 230 kV Lines	106.76%	<100%

Table F.6-29: Lakeville - Ignacio #2 230kV on-peak deliverability constraint summary

Affected transmission zones		North of Greater Bay Area	
		HSN	SSN
Portfolio resources behind the constraint (Installed FCDS capacity)		326	N/A
Generic portfolio battery storage behind the constraint (Installed FCDS capacity)		0	N/A
Deliverable portfolio resources w/o mitigation (Installed FCDS capacity)		0	N/A
Total undeliverable baseline and portfolio resources (Installed FCDS capacity)		407	N/A
Mitigation Options	RAS	N/A	N/A
	Reduce generic battery storage (MW)	N/A	N/A
	Transmission upgrade including cost	N/A	N/A
Recommended Mitigation		Continue to monitor	N/A

### Melones - Cottle 230 kV Line on-peak deliverability constraint

The deliverability of renewable portfolio resources in the Northern California area is limited by thermal overloading of the Melones - Cottle 230 kV Line under NERC category P0 contingency as shown in Table F.6-30. This constraint was identified in the baseline portfolio under HSN and SSN conditions. As shown in Table F.6-31, 826 MW of renewable and energy storage would be deliverable without any transmission upgrades. The ISO will continue to monitor this constraint.

Table F.6-30: Melones - Cottle 230 kV Line on-peak deliverability constraint

Overloaded Facility	Contingency	Base Portfolio Loading	
		HSN	SSN
Melones Cottle 230 kV Line	Base Case	111.19%	123.41%

Table F.6-31: Melones - Cottle 230 kV Line on-peak deliverability constraint summary

Affected transmission zones		North of Greater Bay Area	
		HSN	SSN
Portfolio resources behind the constraint (Installed FCDS capacity)		1141	1151
Generic portfolio battery storage behind the constraint (Installed FCDS capacity)		310	310
Deliverable portfolio resources w/o mitigation (Installed FCDS capacity)		826	0
Total undeliverable baseline and portfolio resources (Installed FCDS capacity)		779	1522
Mitigation Options	RAS	N/A	
	Reduce generic battery storage (MW)	N/A	
	Transmission upgrade including cost	N/A	
Recommended Mitigation		Continue to Monitor	

Hopland Bank 115/60 kV #2 on-peak deliverability constraint

The deliverability of renewable portfolio resources in the Northern California area is limited by thermal overloading of the Hopland Bank 115/60 kV Bank No.2 under NERC category P0 and P7 contingencies as shown in Table F.6-32. This constraint was identified in the baseline portfolio under HSN and SSN conditions. As shown in Table F.6-33, 0 MW of renewable and energy storage would be deliverable without any transmission upgrades. The constraint can be mitigated by a planned PG&E maintenance project.

Table F.6-32: Hopland Bank 115/60 kV #2 on-peak deliverability constraint

Overloaded Facility	Contingency	Base Portfolio Loading	
		HSN	SSN
Hopland Bank 115/60 kV #2	Base Case	122.55%	<100%
	Geysers #9-Lakeville & Eagle Rock-Fulton-Silverado Lines	155.08%	148.01%

Table F.6-33: Hopland Bank 115/60 kV #2 on-peak deliverability constraint summary

Affected transmission zones		North of Greater Bay Area	
		HSN	SSN
Portfolio resources behind the constraint (Installed FCDS capacity)		210	205
Generic portfolio battery storage behind the constraint (Installed FCDS capacity)		0	0
Deliverable portfolio resources w/o mitigation (Installed FCDS capacity)		0	1
Total undeliverable baseline and portfolio resources (Installed FCDS capacity)		629	614
Mitigation Options	RAS	N/A	
	Reduce generic battery storage (MW)	N/A	

	Transmission upgrade including cost	N/A
Recommended Mitigation		PG&E Maintenance Project

Geyser # 3 - Cloverdale 115kV (Cloverdale 115KV to MPE Tap 115kV)  
Line on-peak deliverability constraint

The deliverability of renewable portfolio resources in the Northern California area is limited by thermal overloading of the Geyser # 3 - Cloverdale 115kV (Cloverdale 115kV to MPE Tap 115kV) Line under NERC category P7 contingencies as shown in Table F.6-34. This constraint was identified in the baseline portfolio under HSN and SSN conditions. As shown in Table F.6-35, 0 MW of renewable and energy storage would be deliverable without any transmission upgrades. This constraint is currently an identified LDNU and will be addressed through the generator interconnection process.

*Table F.6-34: Geyser # 3 - Cloverdale 115kV (Cloverdale 115KV to MPE Tap 115kV) Line on-peak deliverability constraint*

Overloaded Facility	Contingency	Base Portfolio Loading	
		HSN	SSN
Geyser # 3 - Cloverdale 115kV (Cloverdale 115KV to MPE Tap 115kV) Line	Mendocino-Redbud & Cortina-Mendocino #1 Lines	115.58%	<100%
	Eagle Rock -Redbud & Cortina-Mendocino #1 Lines	<100%	111.26%

*Table F.6-35: Geyser # 3 - Cloverdale 115kV (Cloverdale 115KV to MPE Tap 115kV) Line on-peak deliverability constraint summary*

Affected transmission zones		North of Greater Bay Area	
		HSN	SSN
Portfolio resources behind the constraint (Installed FCDS capacity)		166	166
Generic portfolio battery storage behind the constraint (Installed FCDS capacity)		0	0
Deliverable portfolio resources w/o mitigation (Installed FCDS capacity)		0	0
Total undeliverable baseline and portfolio resources (Installed FCDS capacity)		346	268
Mitigation Options	RAS	N/A	
	Reduce generic battery storage (MW)	N/A	
	Transmission upgrade including cost	N/A	
Recommended Mitigation		This constraint is currently an identified LDNU and will be addressed through the generator interconnection process.	

Geyser #3 - Eagle Rock 115 kV Line on-peak deliverability constraint

The deliverability of renewable portfolio resources in the Northern California area is limited by thermal overloading of the Geyser #3 - Eagle Rock 115 kV under NERC category P1 contingency as shown in Table F.6-36. This constraint was identified in the baseline portfolio under HSN and SSN conditions. As shown in Table F.6-37, 65 MW of renewable and energy storage would be deliverable without any transmission upgrades. This constraint is currently an identified LDNU and will be addressed through the generator interconnection process.

*Table F.6-36: Geyser #3 - Eagle Rock 115 kV Line on-peak deliverability constraint*

Overloaded Facility	Contingency	Base Portfolio Loading	
		HSN	SSN
Geyser #3 - Eagle Rock 115 kV	Ukiah-Hopland-Cloverdale 115Kv	111.42%	112.68%

*Table F.6-37: Geyser #3 - Eagle Rock 115 kV Line on-peak deliverability constraint summary*

Affected transmission zones		North of Greater Bay Area	
		HSN	SSN
Portfolio resources behind the constraint (Installed FCDS capacity)		87	82
Generic portfolio battery storage behind the constraint (Installed FCDS capacity)		0	0
Deliverable portfolio resources w/o mitigation (Installed FCDS capacity)		65	62
Total undeliverable baseline and portfolio resources (Installed FCDS capacity)		21	20
Mitigation Options	RAS	N/A	
	Reduce generic battery storage (MW)	N/A	
	Transmission upgrade including cost	N/A	
Recommended Mitigation		This constraint is currently an identified LDNU and will be addressed through the generator interconnection process.	

Eagle Rock 115/60 kV Transformer Bank No.1 on-peak deliverability constraint

The deliverability of renewable portfolio resources in the Northern California area is limited by thermal overloading of the Eagle Rock 115/60 kV Transformer Bank No.1 under NERC category P1 contingency as shown in Table F.6-38. This constraint was identified in the baseline portfolio under HSN conditions. As shown in Table F.6-39, 54 MW of renewable and energy storage would be deliverable without any transmission upgrades. The ISO will continue to monitor this constraint.

*Table F.6-38: Eagle Rock 115/60 kV Transformer Bank No.1 on-peak deliverability constraint*

Overloaded Facility	Contingency	Base Portfolio Loading	
		HSN	SSN
Eagle Rock 115/60 kV Transformer Bank No.1	Ukiah-Hopland-Cloverdale 115Kv	106.08%	<100%

*Table F.6-39: Eagle Rock 115/60 kV Transformer Bank No.1 on-peak deliverability constraint summary*

Affected transmission zones		North of Greater Bay Area	
		HSN	SSN
Portfolio resources behind the constraint (Installed FCDS capacity)		200	N/A
Generic portfolio battery storage behind the constraint (Installed FCDS capacity)		0	
Deliverable portfolio resources w/o mitigation (Installed FCDS capacity)		54	
Total undeliverable baseline and portfolio resources (Installed FCDS capacity)		145	
Mitigation Options	RAS	N/A	
	Reduce generic battery storage (MW)	N/A	
	Transmission upgrade including cost	N/A	
Recommended Mitigation		Continue to Monitor	

Clear Lake - Eagle Rock 60 kV (Clear Lake 60 kV sub to Konocti Sub 60 kV) Line on-peak deliverability constraint

The deliverability of renewable portfolio resources in the Northern California area is limited by thermal overloading of the Clear Lake - Eagle Rock 60 kV (Clear Lake 60 kV sub to Konocti Sub 60 kV) Line under NERC category P1 contingency as shown in Table F.6-40. This constraint was identified in the baseline portfolio under HSN conditions. As shown in Table F.6-41, 81 MW of renewable and energy storage would be deliverable without any

transmission upgrades. This is a local constraint and will be addressed through the generator interconnection process.

Table F.6-40: Clear Lake - Eagle Rock 60 kV (Clear Lake 60 kV sub to Konocti Sub 60 kV) Line on-peak deliverability constraint

Overloaded Facility	Contingency	Base Portfolio Loading	
		HSN	SSN
Clear Lake - Eagle Rock 60 kV (Clear Lake 60 kV sub to Konocti Sub 60 kV)	Ukiah-Hopland-Cloverdale 115Kv	108.4%	<100%

Table F.6-41: Clear Lake - Eagle Rock 60 kV (Clear Lake 60 kV sub to Konocti Sub 60 kV) Line on-peak deliverability constraint summary

Affected transmission zones		North of Greater Bay Area	
		HSN	SSN
Portfolio resources behind the constraint (Installed FCDS capacity)		200	N/A
Generic portfolio battery storage behind the constraint (Installed FCDS capacity)		0	
Deliverable portfolio resources w/o mitigation (Installed FCDS capacity)		81	
Total undeliverable baseline and portfolio resources (Installed FCDS capacity)		118	
Mitigation Options	RAS	N/A	
	Reduce generic battery storage (MW)	N/A	
	Transmission upgrade including cost	N/A	
Recommended Mitigation		Local Constraint, will be addressed through the generator interconnection process.	

Ukiah-Hopland-Cloverdale 115 kV (Ukiah sub 115kv to Hopland Jct 115kv) Line on-peak deliverability constraint

The deliverability of renewable portfolio resources in the Northern California area is limited by thermal overloading of the Ukiah-Hopland-Cloverdale 115 kV (Ukiah sub 115kv to Hopland Jct 115kv) under NERC category P7 contingency as shown in Table F.6-42. This constraint was identified in the baseline portfolio under HSN and SSN conditions. As shown in Table F.6-43, 0 MW of renewable and energy storage would be deliverable without any transmission upgrades. This constraint is currently an identified LDNU and will be addressed through the generator interconnection process.

Table F.6-42: Ukiah-Hopland-Cloverdale 115 kV (Ukiah sub 115kv to Hopland Jct 115kv) on-peak deliverability constraint

Overloaded Facility	Contingency	Base Portfolio Loading	
		HSN	SSN
Ukiah-Hopland-Cloverdale 115 kV (Ukiah sub 115kv to Hopland Jct 115kv)	Mendocino-Redbud & Cortina-Mendocino #1 Lines	118.42%	115.68%

Table F.6-43: Ukiah-Hopland-Cloverdale 115 kV (Ukiah sub 115kv to Hopland Jct 115kv) on-peak deliverability constraint summary

Affected transmission zones		North of Greater Bay Area	
		HSN	SSN
Portfolio resources behind the constraint (Installed FCDS capacity)		200	195
Generic portfolio battery storage behind the constraint (Installed FCDS capacity)		0	0
Deliverable portfolio resources w/o mitigation (Installed FCDS capacity)		0	0
Total undeliverable baseline and portfolio resources (Installed FCDS capacity)		453	325
Mitigation Options	RAS	N/A	
	Reduce generic battery storage (MW)	N/A	
	Transmission upgrade including cost	N/A	
Recommended Mitigation		This constraint is currently an identified LDNU and will be addressed through the generator interconnection process.	

Cortina - Vaca 230 kV Line on-peak deliverability constraint

The deliverability of renewable portfolio resources in the Northern California area is limited by thermal overloading of the Cortina - Vaca 230 kV Line under NERC category P7 contingency as shown in Table F.6-44. This constraint was identified in the baseline portfolio under HSN and SSN conditions. As shown in Table F.6-45, 846 MW of renewable and energy storage would be deliverable without any transmission upgrades. The ISO will continue to monitor this constraint.

Table F.6-44: Cortina - Vaca 230 kV Line on-peak deliverability constraint

Overloaded Facility	Contingency	Base Portfolio Loading	
		HSN	SSN
Cortina - Vaca 230 kV Line	Delevan-Vaca Dixon No.2 230 KV Line & Delevan-Vaca Dixon No.3 230 KV Line	101.63%	103.89%

Table F.6-45: Cortina - Vaca 230 kV Line on-peak deliverability constraint summary

Affected transmission zones		North of Greater Bay Area	
		HSN	SSN
Portfolio resources behind the constraint (Installed FCDS capacity)		790	785
Generic portfolio battery storage behind the constraint (Installed FCDS capacity)		270	270
Deliverable portfolio resources w/o mitigation (Installed FCDS capacity)		846	791
Total undeliverable baseline and portfolio resources (Installed FCDS capacity)		419	479
Mitigation Options	RAS	N/A	
	Reduce generic battery storage (MW)	N/A	
	Transmission upgrade including cost	N/A	
Recommended Mitigation		Continue to Monitor	

Lincoln - Pleasant Grove 115 kV Line on-peak deliverability constraint

The deliverability of renewable portfolio resources in the Northern California area is limited by thermal overloading of the Lincoln - Pleasant Grove 115 kV Line under NERC category P7 contingency as shown in Table F.6-46. This constraint was identified in the baseline portfolio under HSN and SSN conditions. As shown in Table F.6-47, 0 MW of renewable and energy storage would be deliverable without any transmission upgrades. The constraint will be mitigated through a TPP reliability project.

Table F.6-46: Lincoln - Pleasant Grove 115 kV Line on-peak deliverability constraint

Overloaded Facility	Contingency	Base Portfolio Loading	
		HSN	SSN
Lincoln - Pleasant Grove 115 kV Line	Rio Oso-Atlantic 230 KV Line & Rio Oso-Gold Hill 230 KV Line	113.69%	105.19%

Table F.6-47: Lincoln - Pleasant Grove 115 kV Line on-peak deliverability constraint summary

Affected transmission zones	North of Greater Bay Area	
	HSN	SSN
Portfolio resources behind the constraint (Installed FCDS capacity)	36	36
Generic portfolio battery storage behind the constraint (Installed FCDS capacity)	35	35
Deliverable portfolio resources w/o mitigation (Installed FCDS capacity)	0	0

Total undeliverable baseline and portfolio resources (Installed FCDS capacity)		350	246
Mitigation Options	RAS	N/A	
	Reduce generic battery storage (MW)	N/A	
	Transmission upgrade including cost	N/A	
Recommended Mitigation		The constraint will be mitigated through a TPP reliability project.	

Rio Oso - Atlantic 230 kV Line No. 1 on-peak deliverability constraint

The deliverability of renewable portfolio resources in the Northern California area is limited by thermal overloading of the Rio Oso - Atlantic 230 kV Line No. 1 under NERC category P1 contingency as shown in Table F.6-48. This constraint was identified in the baseline portfolio under HSN conditions. As shown in Table F.6-49, 12 MW of renewable and energy storage would be deliverable without any transmission upgrades. The ISO will continue to monitor this constraint.

*Table F.6-48: Rio Oso - Atlantic 230 kV Line No. 1 on-peak deliverability constraint*

Overloaded Facility	Contingency	Base Portfolio Loading	
		HSN	SSN
Rio Oso - Atlantic 230 kV Line No. 1	Rio Oso – Gold Hill 230KV	100.3%	<100%

*Table F.6-49: Rio Oso - Atlantic 230 kV Line No. 1 on-peak deliverability constraint summary*

Affected transmission zones		North of Greater Bay Area	
		HSN	SSN
Portfolio resources behind the constraint (Installed FCDS capacity)		36	N/A
Generic portfolio battery storage behind the constraint (Installed FCDS capacity)		35	
Deliverable portfolio resources w/o mitigation (Installed FCDS capacity)		12	
Total undeliverable baseline and portfolio resources (Installed FCDS capacity)		180	
Mitigation Options	RAS	N/A	
	Reduce generic battery storage (MW)	N/A	
	Transmission upgrade including cost	N/A	
Recommended Mitigation		Continue to Monitor	

Drum - Higgins 115 kV Line on-peak deliverability constraint

The deliverability of renewable portfolio resources in the Northern California area is limited by thermal overloading of the Drum - Higgins 115 kV Line under NERC category P7 contingency as shown in Table F.6-50. This constraint was identified in the baseline portfolio under HSN and SSN conditions. As shown in Table F.6-51, 0 MW of renewable and energy storage would be deliverable without any transmission upgrades. This constraint will be mitigated by the Drum-Higgins 115kV Line Reconductoring Project.

*Table F.6-50: Drum - Higgins 115 kV Line on-peak deliverability constraint*

Overloaded Facility	Contingency	Base Portfolio Loading	
		HSN	SSN
Drum - Higgins 115 kV Line	Rio Oso-Atlantic 230 KV Line & Rio Oso-Gold Hill 230 KV Line	130.26%	115.81%

*Table F.6-51: Drum - Higgins 115 kV Line on-peak deliverability constraint summary*

Affected transmission zones		North of Greater Bay Area	
		HSN	SSN
Portfolio resources behind the constraint (Installed FCDS capacity)		39	39
Generic portfolio battery storage behind the constraint (Installed FCDS capacity)		0	0
Deliverable portfolio resources w/o mitigation (Installed FCDS capacity)		0	0
Total undeliverable baseline and portfolio resources (Installed FCDS capacity)		217	80
Mitigation Options	RAS	N/A	
	Reduce generic battery storage (MW)	N/A	
	Transmission upgrade including cost	Drum-Higgins 115kV Line Reconductoring Project (\$154.19-\$308.37 M).	
Recommended Mitigation		Drum-Higgins 115kV Line Reconductoring Project.	

**F.6.3. 2040 Off-Peak Results**

The off-peak deliverability constraints identified in the baseline portfolio assessment of the PG&E North of Greater Bay interconnection area, along with the recommended mitigation plans, are identified in Table F.6-52.

Table F.6-52: PG&E North of Greater Bay Interconnection Area Off-Peak deliverability constraints

Constraint	Contingency	Loading (%)	Renewable Portfolio MW behind Constraint	Energy Storage Portfolio MW behind Constraint	Renewable curtailment without mitigation	Potential Mitigation
Gold Hill - Lake 230 kV Line	Brighton-Bellota 230 KV Line & Rio Oso-Lockeford 230 KV Line	145.5	70	35	35	Mitigation to be developed if economic.

### F.6.4. Conclusion and recommendation

The PGE North of Greater Bay area base and sensitivity portfolios deliverability assessment identified on-peak and off-peak constraints. As part of mitigation, the ISO recommends the Drum – Higgins 115 kV Line Reconductoring Project. Most of the other constraints are mitigated through network upgrades identified in the generator interconnection process or the TPP reliability study process.

## F.7. PG&E Greater Bay Interconnection Area

The total capacity of resources, by resource type, selected with Full Capacity Deliverability Status (FCDS) as well as those selected as Energy Only (EO) in the PG&E Greater Bay interconnection area are listed in Table F.7-1. The portfolios in the interconnection area are comprised of solar, wind (in-state and offshore), battery storage, geothermal, biomass/biogas and distributed solar resources. All portfolio resources are modeled in policy-driven assessments except in the on-peak deliverability assessment in which only FCDS resources are modeled.

Table F.7-1: PG&E Greater Bay Interconnection Area Base & Sensitivity Portfolios<sup>2</sup>

Resource Type	2035 Base Portfolio			2040 Base Portfolio			2035 Sensitivity Portfolio		
	FCDS (MW)	EO (MW)	Total (MW)	FCDS (MW)	EO (MW)	Total (MW)	FCDS (MW)	EO (MW)	Total (MW)
Solar	0	250	250	252	1,150	1,402	0	100	100
Wind – In State	827	187	1,014	827	187	1,014	827	187	1,014
Wind – Out-of-State	0	0	0	1,707	0	1,707	0	0	0
Wind - Offshore	0	0	0	0	0	0	0	0	0
Li Battery – 4 hr.	2,573	0	2,573	2,108	0	2,108	2,488	0	2,488
Li Battery – 8 hr.	236	0	236	1,508	0	1,508	261	0	261
Long Duration Energy Storage (LDES)	243	0	243	243	0	243	243	0	243
Geothermal	0	0	0	0	0	0	0	0	0
Biomass/Biogas	12	0	12	12	0	12	12	0	12
Distributed Solar	0	44	44	0	44	44	0	44	44
<b>Totals</b>	<b>3,891</b>	<b>481</b>	<b>4,372</b>	<b>6,657</b>	<b>1,381</b>	<b>8,038</b>	<b>3,831</b>	<b>331</b>	<b>4,162</b>

The resources as identified in the CPUC busbar mapping for the PG&E Greater Bay interconnection area are illustrated on the single-line diagrams in Figure F.7-1, Figure F.7-2 and Figure F.7-3.

<sup>2</sup> Numbers include the adjustments to the base portfolio made by CPUC staff in the Greater Bay Interconnection Area to account for allocated TPD, additional in-development resources identified and non-CPUC jurisdictional IRP plan resources.

Figure F.7-1: Greater Bay Interconnection Area – Mapped 2035 Base Portfolio

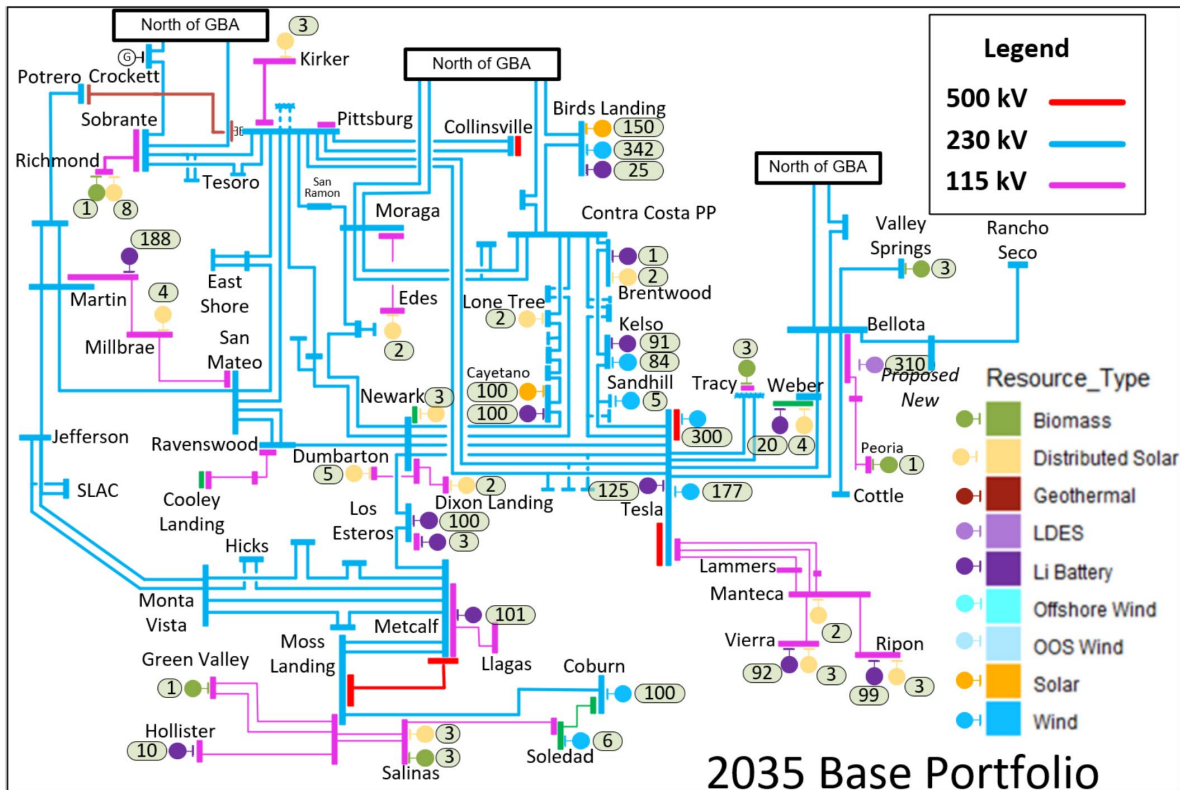

Figure F.7-2: Greater Bay Interconnection Area – Mapped 2040 Base Portfolio

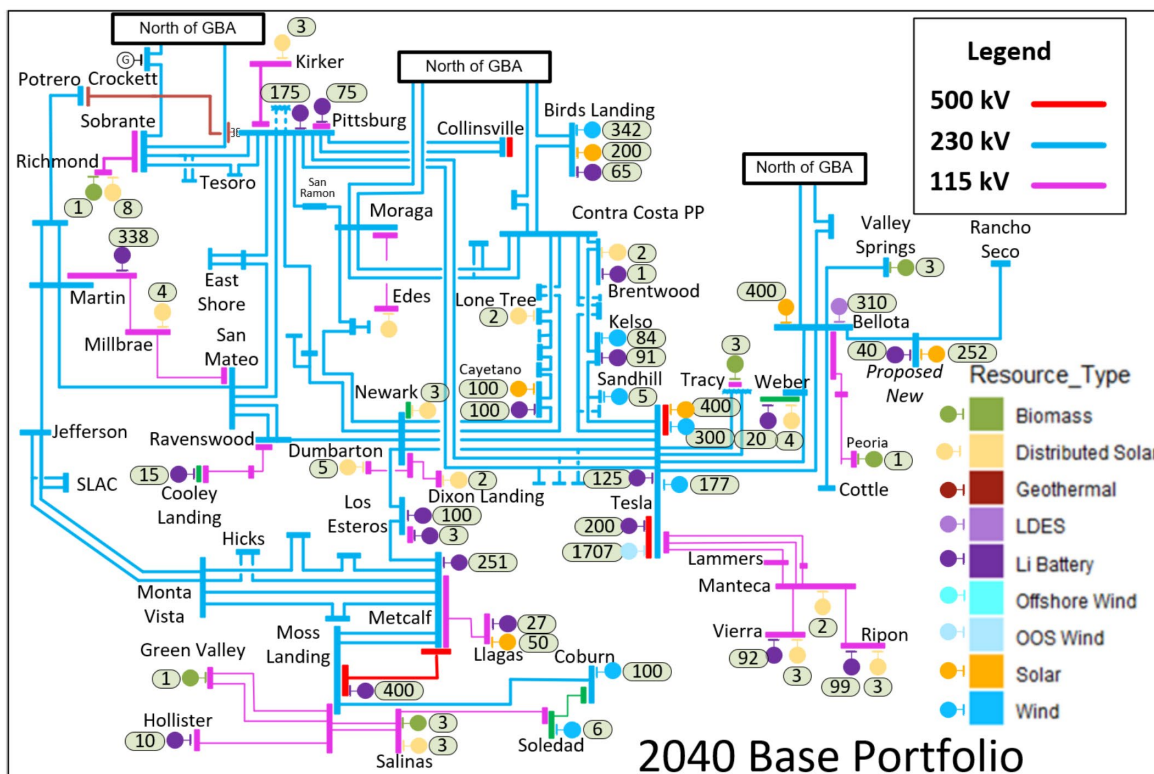
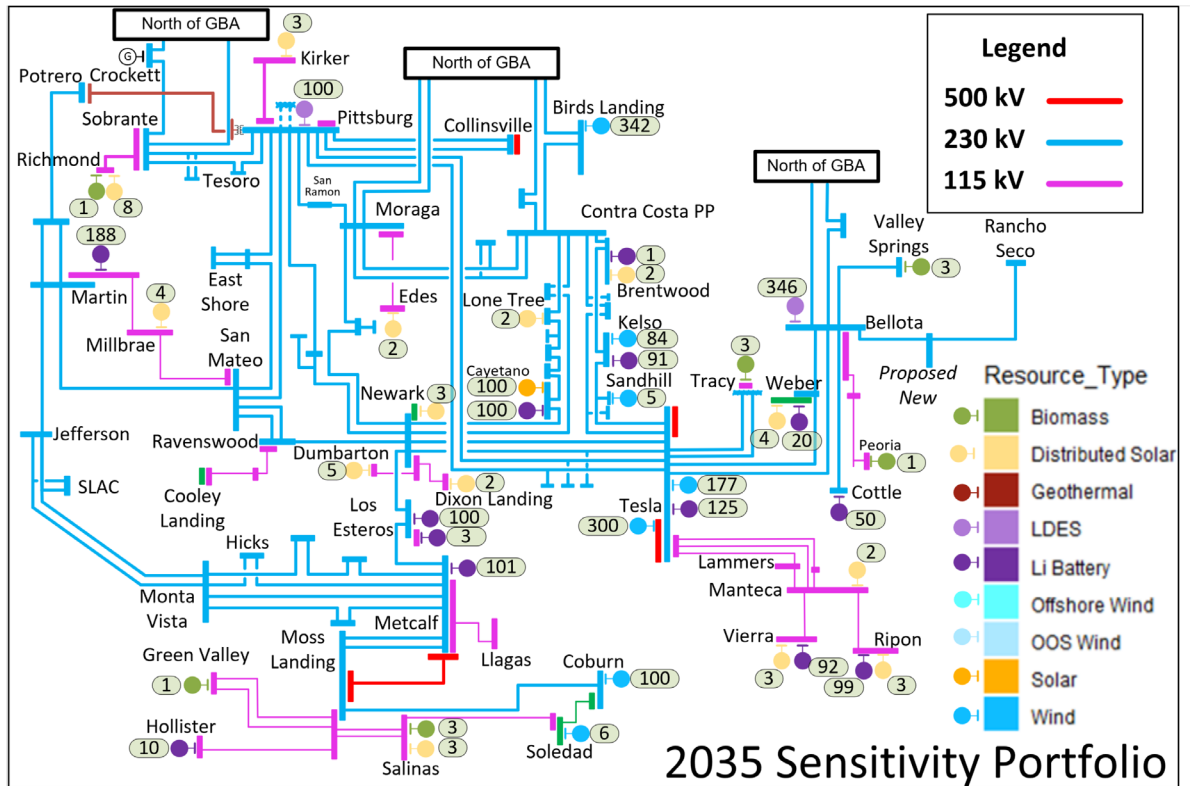

Figure F.7-3: Greater Bay Interconnection Area – Mapped 2035 Sensitivity Portfolio



### F.7.1. 2035 On-Peak Results

#### Oakland J - Grant 115kV Line on-peak deliverability constraint

The deliverability of renewable portfolio resources in the Northern California area is limited by thermal overloading of the Oakland J - Grant 115kV Line under NERC category P7 contingency as shown in Table F.7-2. This constraint was identified in baseline and sensitivity portfolio under HSN conditions. As shown in Table F.7-3, 0 MW of renewable and energy storage would be deliverable without any transmission upgrades. The constraint will be mitigated through a TPP reliability project.

Table F.7-2: Oakland J - Grant 115kV Line on-peak Deliverability Constraint

Overloaded Facility	Contingency	Scenario	Loading	
			Base	Sensitivity
Oakland J - Grant 115kV Line	Pittsburg-San Mateo 230 KV and Pittsburg-East Shore 230 KV lines	HSN	116.43%	106.36%

Table F.7-3: Oakland J - Grant 115kV Line on-peak deliverability constraint summary

Affected transmission zones		Greater Bay Area	
		Base	Sensitivity
Portfolio resources behind the constraint (Installed FCDS capacity)		0.5	4
Generic portfolio battery storage behind the constraint (Installed FCDS capacity)		675	575
Deliverable portfolio resources w/o mitigation (Installed FCDS capacity)		0	48
Total undeliverable baseline and portfolio resources (Installed FCDS capacity)		1009	558
Mitigation Options	RAS	N/A	
	Reduce generic battery storage (MW)	N/A	
	Transmission upgrade including cost	N/A	
Recommended Mitigation		The constraint will be mitigated through a TPP reliability project.	

### Oleum-Martinez 115kV Line on-peak deliverability constraint

The deliverability of renewable portfolio resources in the Northern California area is limited by thermal overloading of the Oleum-Martinez 115kV Line under NERC category P7 contingency as shown in Table F.6-24. This constraint was identified in baseline and sensitivity portfolio under HSN conditions. As shown in Table F.7-4, 0 MW of renewable and energy storage would be deliverable without any transmission upgrades. The constraint will be mitigated through the Oleum Area Reinforcement Project.

Table F.7-4: Oleum-Martinez 115kV Line on-peak Deliverability Constraint

Overloaded Facility	Contingency	Scenario	Loading	
			Base	Sensitivity
Oleum-Martinez 115kV Line	Sobrante-G Nos. 1 & 2 115 KV lines	HSN	129.29%	121.36%

Table F.7-5: Oleum-Martinez 115kV Line on-peak deliverability constraint summary

Affected transmission zones		Greater Bay Area	
		Base	Sensitivity
Portfolio resources behind the constraint (Installed FCDS capacity)		0	0
Generic portfolio battery storage behind the constraint (Installed FCDS capacity)		675	325
Deliverable portfolio resources w/o mitigation (Installed FCDS capacity)		0	0
Total undeliverable baseline and portfolio resources (Installed FCDS capacity)		937	688
Mitigation Options	RAS	N/A	

	Reduce generic battery storage (MW)	N/A
	Transmission upgrade including cost	Oleum Area Reinforcement Project (\$82.78-\$144.29M)
Recommended Mitigation		Oleum Area Reinforcement Project

### Oleum Area Reinforcement Project

To mitigate overloads identified in the on-peak baseline and sensitivity deliverability study, the ISO is recommending for approval the Oleum Area Reinforcement Project. The estimated project cost range is \$82.78-\$144.29M, with an expected in-service date of 2033.

The project scope includes the following:

- Reconductoring the entire Oleum-Martinez 115kV line (approximately 10.49 mile) with minimum SN rating of 1714 Amps (341 MVA, 954ACSS);
- Reconductoring the Martinez-Sobrante 115kV line from Martinez PP-Alhambra (approximately 2.42 mile) with minimum SN rating of 1714 Amps (341 MVA, 954ACSS); and
- Upgrade the limiting elements to achieve the line conductor ratings.

Figure 7-4: Oleum Area Reinforcement

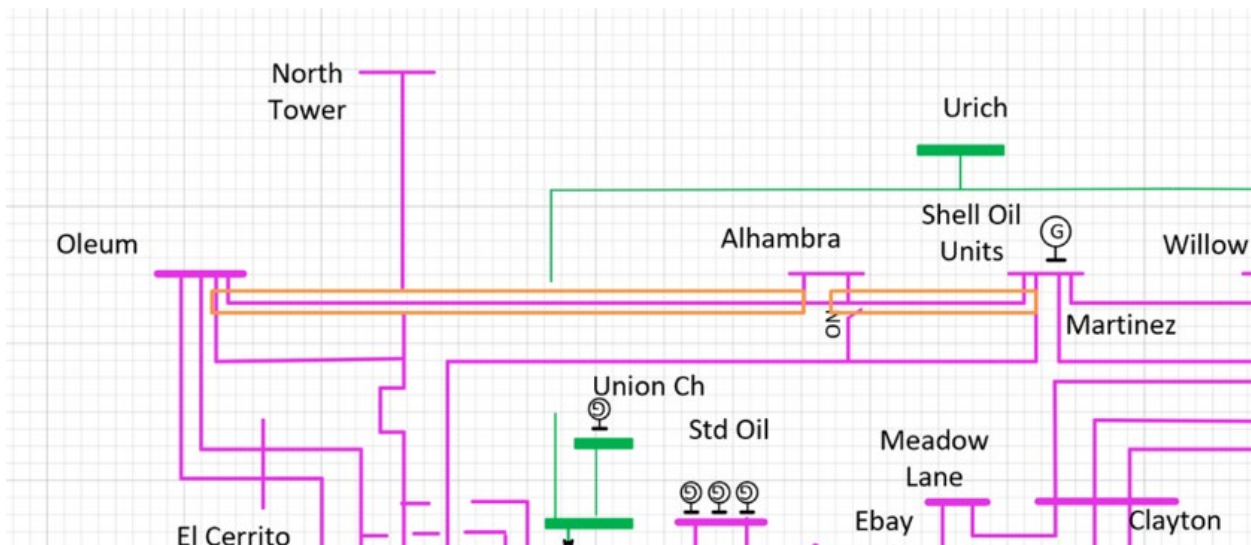

Moraga-Castro Valley 230kV Line on-peak deliverability constraint

The deliverability of renewable portfolio resources in the Northern California area is limited by thermal overloading of the Moraga-Castro Valley 230kV Line under NERC category P7 contingency as shown in Table F.7-6. This constraint was identified in baseline and sensitivity portfolio under HSN conditions. As shown in Table F.7-7, 0 MW of renewable and energy storage would be deliverable without any transmission upgrades. The constraint will be mitigated through a TPP reliability project.

Table F.7-6: Moraga-Castro Valley 230kV Line on-peak Deliverability Constraint

Overloaded Facility	Contingency	Scenario	Loading	
			Base	Sensitivity
Moraga-Castro Valley 230kV Line	Tesla - Newark No.2 and Metcalf - Los Esteros 230 KV lines	HSN	113.89%	<100
	Las Positas-Newark 230 KV and North Dublin-Vineyard 230 KV lines		<100	119.9%

Table F.7-7: Moraga-Castro Valley 230kV Line on-peak deliverability constraint summary

Affected transmission zones		Greater Bay Area	
		Base	Sensitivity
Portfolio resources behind the constraint (Installed FCDS capacity)		4	309
Generic portfolio battery storage behind the constraint (Installed FCDS capacity)		675	131
Deliverable portfolio resources w/o mitigation (Installed FCDS capacity)		0	0
Total undeliverable baseline and portfolio resources (Installed FCDS capacity)		1140	3000
Mitigation Options	RAS	N/A	
	Reduce generic battery storage (MW)	N/A	
	Transmission upgrade including cost	N/A	
Recommended Mitigation		The constraint will be mitigated through a TPP reliability project.	

Tassajara-Newark 230kV Line on-peak deliverability constraint

The deliverability of renewable portfolio resources in the Northern California area is limited by thermal overloading of the Tassajara-Newark 230kV Line under NERC category P7 contingency as shown in Table F.7-8. This constraint was identified in baseline and sensitivity portfolio under HSN conditions. As shown in Table F.7-9, 772 MW of renewable and energy storage would be deliverable without any transmission upgrades. The constraint will be mitigated through a TPP reliability project.

Table F.7-8: Tassajara-Newark 230kV Line on-peak Deliverability Constraint

Overloaded Facility	Contingency	Scenario	Loading	
			Base	Sensitivity
Tassajara-Newark 230kV Line	Tesla - Newark No.2 and Metcalf - Los Esteros 230 KV lines	HSN	104.42%	111.77%

Table F.7-9: Tassajara-Newark 230kV Line on-peak deliverability constraint summary

Affected transmission zones		Greater Bay Area	
		Base	Sensitivity
Portfolio resources behind the constraint (Installed FCDS capacity)		0	0
Generic portfolio battery storage behind the constraint (Installed FCDS capacity)		1002	902
Deliverable portfolio resources w/o mitigation (Installed FCDS capacity)		772	385
Total undeliverable baseline and portfolio resources (Installed FCDS capacity)		230	517
Mitigation Options	RAS	N/A	
	Reduce generic battery storage (MW)	N/A	
	Transmission upgrade including cost	N/A	
Recommended Mitigation		The constraint will be mitigated through a TPP reliability project.	

Los Esteros-Silicon Switching Station 230 kV Line on-peak deliverability constraint

The deliverability of renewable portfolio resources in the Northern California area is limited by thermal overloading of the Los Esteros-Silicon Switching Station 230 kV Line under NERC category P7 contingency as shown in Table F.7-10. This constraint was identified in baseline and sensitivity portfolio under HSN conditions. As shown in Table F.7-11, 37 MW of renewable and energy storage would be deliverable without any transmission upgrades. The constraint will be mitigated through a TPP reliability project.

Table F.7-10: Los Esteros-Silicon Switching Station 230 kV Line on-peak Deliverability Constraint

Overloaded Facility	Contingency	Scenario	Loading	
			Base	Sensitivity
Los Esteros-Silicon Switching Station 230 kV Line	Los Esteros - Trimble & Los Esteros - Montague 115 KV	HSN	100.86%	100.08%

Table F.7-11: Los Esteros-Silicon Switching Station 230 kV Line on-peak deliverability constraint summary

Affected transmission zones		Greater Bay Area	
		Base	Sensitivity
Portfolio resources behind the constraint (Installed FCDS capacity)		0	0
Generic portfolio battery storage behind the constraint (Installed FCDS capacity)		100	100
Deliverable portfolio resources w/o mitigation (Installed FCDS capacity)		37	73
Total undeliverable baseline and portfolio resources (Installed FCDS capacity)		63	27
Mitigation Options	RAS	N/A	
	Reduce generic battery storage (MW)	N/A	
	Transmission upgrade including cost	N/A	
Recommended Mitigation		The constraint will be mitigated through a TPP reliability project.	

Nortech-NRS 115 kV Line on-peak deliverability constraint

The deliverability of renewable portfolio resources in the Northern California area is limited by thermal overloading of the Nortech-NRS 115 kV Line under NERC category P7 contingency as shown in Table F.7-12. This constraint was identified in baseline and sensitivity portfolio under HSN conditions. As shown in Table F.7-13, 0 MW of renewable and energy storage would be deliverable without any transmission upgrades. The constraint will be mitigated through a TPP reliability project.

Table F.7-12: Nortech-NRS 115 kV Line on-peak Deliverability Constraint

Overloaded Facility	Contingency	Scenario	Loading	
			Base	Sensitivity
Nortech-NRS 115 kV Line	Los Esteros - Trimble & Los Esteros - Montague 115 KV	HSN	108.39%	107.94%

Table F.7-13: Nortech-NRS 115 kV Line on-peak deliverability constraint summary

Affected transmission zones		Greater Bay Area	
		Base	Sensitivity
Portfolio resources behind the constraint (Installed FCDS capacity)		0	0
Generic portfolio battery storage behind the constraint (Installed FCDS capacity)		103	103
Deliverable portfolio resources w/o mitigation (Installed FCDS capacity)		0	0
Total undeliverable baseline and portfolio resources (Installed FCDS capacity)		136	132

Mitigation Options	RAS	N/A
	Reduce generic battery storage (MW)	N/A
	Transmission upgrade including cost	N/A
Recommended Mitigation		The constraint will be mitigated through a TPP reliability project.

Martinez-Noth Tower 115kv (Nrth twr to Alhamtp1 115kV)(New) line on-peak deliverability constraint

The deliverability of renewable portfolio resources in the Northern California area is limited by thermal overloading of the Martinez-Noth Tower 115kv (Nrth twr to Alhamtp1 115kV)(New) Line under NERC category P7 contingency as shown in Table F.7-14. This constraint was identified in baseline and sensitivity portfolio under HSN conditions. As shown in Table F.7-15, 805 MW of renewable and energy storage would be deliverable without any transmission upgrades. The constraint will be mitigated through the Oleum Area Reinforcement Project.

*Table F.7-14: Martinez-Noth Tower 115kv (Nrth twr to Alhamtp1 115kV)(New) Line on-peak Deliverability Constraint*

Overloaded Facility	Contingency	Scenario	Loading	
			Base	Sensitivity
Martinez-Noth Tower 115kv (Nrth twr to Alhamtp1 115kV)(New)	Pittsburg-Tidewater 230 KV and Pittsburg-Tesoro SW STA 230 KV lines	HSN	108.12%	100.61%

*Table F.7-15: Martinez-Noth Tower 115kv (Nrth twr to Alhamtp1 115kV)(New) Line on-peak deliverability constraint summary*

Affected transmission zones		Greater Bay Area	
		Base	Sensitivity
Portfolio resources behind the constraint (Installed FCDS capacity)		0	0
Generic portfolio battery storage behind the constraint (Installed FCDS capacity)		1000	900
Deliverable portfolio resources w/o mitigation (Installed FCDS capacity)		805	875
Total undeliverable baseline and portfolio resources (Installed FCDS capacity)		195	25
Mitigation Options	RAS	N/A	
	Reduce generic battery storage (MW)	N/A	
	Transmission upgrade including cost	Oleum Area Reinforcement Project (\$82.78-\$144.29M)	
Recommended Mitigation		Oleum Area Reinforcement Project	

Pittsburg-San Mateo 230kV Line on-peak deliverability constraint

The deliverability of renewable portfolio resources in the Northern California area is limited by thermal overloading of the Pittsburg-San Mateo 230kV Line under NERC category P1 contingency as shown in Table F.7-16. This constraint was identified in baseline and sensitivity portfolio under HSN conditions. As shown in Table F.7-17, 0 MW of renewable and energy storage would be deliverable without any transmission upgrades. This constraint can be mitigated by the East Shore 230kV Area Reinforcement Project.

*Table F.7-16: Pittsburg-San Mateo 230kV Line on-peak Deliverability Constraint*

Overloaded Facility	Contingency	Scenario	Loading	
			Base	Sensitivity
Pittsburg-San Mateo 230kV Line	Newark-Ravenswood 230 KV and Tesla-Ravenswood 230 KV lines	HSN	112.83%	118.01%

*Table F.7-17: Pittsburg-San Mateo 230kV Line on-peak deliverability constraint summary*

Affected transmission zones		Greater Bay Area	
		Base	Sensitivity
Portfolio resources behind the constraint (Installed FCDS capacity)		0	0
Generic portfolio battery storage behind the constraint (Installed FCDS capacity)		1002	902
Deliverable portfolio resources w/o mitigation (Installed FCDS capacity)		0	0
Total undeliverable baseline and portfolio resources (Installed FCDS capacity)		1060	1385
Mitigation Options	RAS	N/A	
	Reduce generic battery storage (MW)	N/A	
	Transmission upgrade including cost	East Shore 230kV Area Reinforcement Project (\$128.45M - \$256.9M)	
Recommended Mitigation		East Shore 230kV Area Reinforcement Project.	

East Shore 230kV Area Reinforcement Project

To mitigate overloads identified in the baseline and sensitivity portfolio on-peak deliverability studies, the ISO is recommending for approval, the East Shore 230kV Area Reinforcement Project. The estimated project cost range is \$128.45M - \$256.9M, with an expected in-service date of 2030. The scope includes looping Pittsburg-San Mateo 230kV Line into East Shore 230 kV substation and then reconductoring the remaining sections of the Pittsburg-East Shore 230kV Lines #1 and #2 (13.12 and 23.34 miles). The project scope

also includes updating the limiting components at the substations if necessary.

Figure 7-5: East Shore 230kV Area Reinforcement Project

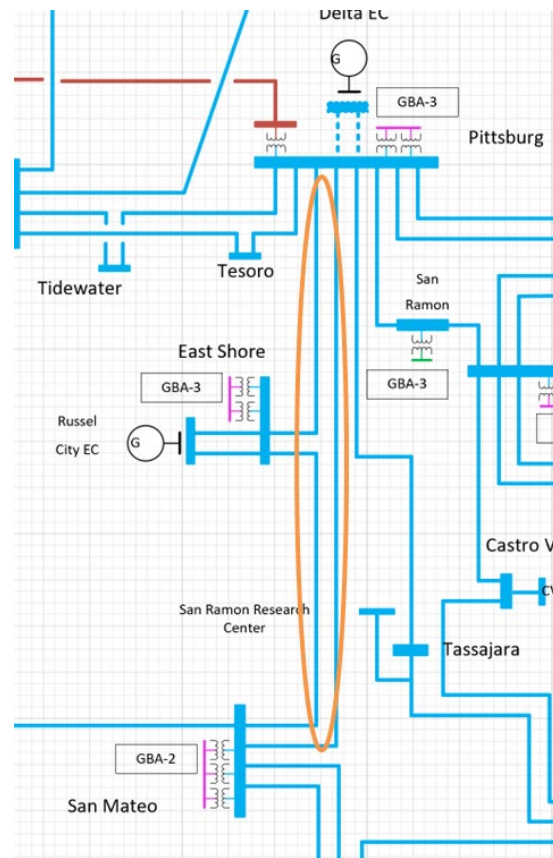

Tesla-Newark #2 230kV Line on-peak deliverability constraint

The deliverability of renewable portfolio resources in the Northern California area is limited by thermal overloading of the Tesla-Newark #2 230kV Line under NERC category P1 contingency as shown in Table F.7-18. This constraint was identified in baseline and sensitivity portfolio under HSN conditions. As shown in Table F.7-19, 0 MW of renewable and energy storage would be deliverable without any transmission upgrades. The constraint will be mitigated through a TPP reliability project.

Table F.7-18: Tesla-Newark #2 230kV Line on-peak Deliverability Constraint

Overloaded Facility	Contingency	Scenario	Loading	
			Base	Sensitivity
Tesla-Newark #2 230kV Line	Tesla-Newark No.1 and Tesla-Ravenswood 230 KV lines	HSN	111.34%	112.07%

Table F.7-19: Tesla-Newark #2 230kV Line on-peak deliverability constraint summary

Affected transmission zones		Greater Bay Area	
		Base	Sensitivity
Portfolio resources behind the constraint (Installed FCDS capacity)		804	804
Generic portfolio battery storage behind the constraint (Installed FCDS capacity)		0	0
Deliverable portfolio resources w/o mitigation (Installed FCDS capacity)		0	0
Total undeliverable baseline and portfolio resources (Installed FCDS capacity)		852	948
Mitigation Options	RAS	N/A	
	Reduce generic battery storage (MW)	N/A	
	Transmission upgrade including cost	N/A	
Recommended Mitigation		The constraint will be mitigated through a TPP reliability project.	

### Castro Valley-Newark 230kV Line on-peak deliverability constraint

The deliverability of renewable portfolio resources in the Northern California area is limited by thermal overloading of the Castro Valley-Newark 230kV Line under NERC category P7 contingency as shown in Table F.7-20. This constraint was identified in baseline and sensitivity portfolio under HSN conditions. As shown in Table F.7-21, 793 MW of renewable and energy storage would be deliverable without any transmission upgrades. The constraint will be mitigated through a TPP reliability project.

Table F.7-20: Castro Valley-Newark 230kV Line on-peak Deliverability Constraint

Overloaded Facility	Contingency	Scenario	Loading	
			Base	Sensitivity
Castro Valley-Newark 230kV Line	Las Positas-Newark 230 KV and North Dublin-Vineyard 230 KV lines	HSN	101.29%	113.1%

Table F.7-21: Castro Valley-Newark 230kV Line on-peak deliverability constraint summary

Affected transmission zones		Greater Bay Area	
		Base	Sensitivity
Portfolio resources behind the constraint (Installed FCDS capacity)		611	309
Generic portfolio battery storage behind the constraint (Installed FCDS capacity)		788	706
Deliverable portfolio resources w/o mitigation (Installed FCDS capacity)		793	0
Total undeliverable baseline and portfolio resources (Installed FCDS capacity)		2155	2806
Mitigation Options	RAS	N/A	

	Reduce generic battery storage (MW)	N/A
	Transmission upgrade including cost	N/A
Recommended Mitigation		The constraint will be mitigated through a TPP reliability project.

Pittsburg-Eastshore 230kV Line on-peak deliverability constraint

The deliverability of renewable portfolio resources in the Northern California area is limited by thermal overloading of the Pittsburg-Eastshore 230kV Line under NERC category P7 contingency as shown in Table F.7-22. This constraint was identified in baseline and sensitivity portfolio under HSN conditions. As shown in Table F.7-23 155 MW of renewable and energy storage would be deliverable without any transmission upgrades. This constraint will be mitigated by the East Shore 230kV Area Reinforcement Project.

Table F.7-22: Pittsburg-Eastshore 230kV Line on-peak Deliverability Constraint

Overloaded Facility	Contingency	Scenario	Loading	
			Base	Sensitivity
Pittsburg-Eastshore 230kV Line	Moraga-Oakland J 115 KV and San Leandro-Oakland J #1 115 KV lines	HSN	113.59%	119.81%

Table F.7-23: Pittsburg-Eastshore 230kV Line on-peak deliverability constraint summary

Affected transmission zones		Greater Bay Area	
		Base	Sensitivity
Portfolio resources behind the constraint (Installed FCDS capacity)		0	0.5
Generic portfolio battery storage behind the constraint (Installed FCDS capacity)		1002	902
Deliverable portfolio resources w/o mitigation (Installed FCDS capacity)		155	0
Total undeliverable baseline and portfolio resources (Installed FCDS capacity)		863	1226
Mitigation Options	RAS	N/A	
	Reduce generic battery storage (MW)	N/A	
	Transmission upgrade including cost	East Shore 230kV Area Reinforcement Project (\$128.45M - \$256.9M)	
Recommended Mitigation		East Shore 230kV Area Reinforcement Project.	

Las Positas-Newark 230kV Line on-peak deliverability constraint

The deliverability of renewable portfolio resources in the Northern California area is limited by thermal overloading of the Las Positas-Newark 230kV Line under NERC category P7 contingencies as shown in Table F.7-24. This constraint was identified in baseline and sensitivity portfolio under HSN conditions. As shown in Table F.7-25, 0 MW of renewable and energy storage would be deliverable without any transmission upgrades. The constraint will be mitigated through a TPP reliability project.

Table F.7-24: Las Positas-Newark 230kV Line on-peak Deliverability Constraint

Overloaded Facility	Contingency	Scenario	Loading	
			Base	Sensitivity
Las Positas-Newark 230kV Line	Contra Costa-Moraga Nos. 1 & 2 230 KV lines	HSN	201.89%	<100
	North Dublin-Cayetano 230Kv		187.43%	199.08%

Table F.7-25: Las Positas-Newark 230kV Line on-peak deliverability constraint summary

Affected transmission zones		Greater Bay Area	
		Base	Sensitivity
Portfolio resources behind the constraint (Installed FCDS capacity)		143	243
Generic portfolio battery storage behind the constraint (Installed FCDS capacity)		75	90
Deliverable portfolio resources w/o mitigation (Installed FCDS capacity)		0	0
Total undeliverable baseline and portfolio resources (Installed FCDS capacity)		2912	3116
Mitigation Options	RAS	N/A	
	Reduce generic battery storage (MW)	N/A	
	Transmission upgrade including cost	N/A	
Recommended Mitigation		The constraint will be mitigated through a TPP reliability project.	

San Jose Sta 'A'-'B' 115 kV Line on-peak deliverability constraint

The deliverability of renewable portfolio resources in the Northern California area is limited by thermal overloading of the San Jose Sta 'A'-'B' 115 kV Line under NERC category P1 contingency as shown in Table F.7-26. This constraint was identified in baseline and sensitivity portfolio under HSN conditions. As shown in Table F.7-27, 0 MW of renewable and energy storage would be deliverable without any transmission upgrades. The constraint will be mitigated through a TPP reliability project.

Table F.7-26: San Jose Sta 'A'-'B' 115 kV Line on-peak Deliverability Constraint

Overloaded Facility	Contingency	Scenario	Loading	
			Base	Sensitivity
San Jose Sta 'A'-'B' 115 kV Line	San Jose B-Stone-Evergreen 115Kv	HSN	112.29%	<100
	Tesla-Metcalf 500Kv		<100	117.05%

Table F.7-27: San Jose Sta 'A'-'B' 115 kV Line on-peak deliverability constraint summary

Affected transmission zones		Greater Bay Area	
		Base	Sensitivity
Portfolio resources behind the constraint (Installed FCDS capacity)		0	0
Generic portfolio battery storage behind the constraint (Installed FCDS capacity)		678	578
Deliverable portfolio resources w/o mitigation (Installed FCDS capacity)		0	0
Total undeliverable baseline and portfolio resources (Installed FCDS capacity)		957	1035
Mitigation Options	RAS	N/A	
	Reduce generic battery storage (MW)	N/A	
	Transmission upgrade including cost	N/A	
Recommended Mitigation		The constraint will be mitigated through a TPP reliability project.	

### Charcot Sw Sta to Montague 115 kV Line on-peak deliverability constraint

The deliverability of renewable portfolio resources in the Northern California area is limited by thermal overloading of the Charcot Sw Sta to Montague 115 kV Line under NERC category P1 contingency as shown in Table F.7-28. This constraint was identified in baseline and sensitivity portfolio under HSN conditions. As shown in Table F.7-29, 0 MW of renewable and energy storage would be deliverable without any transmission upgrades. The constraint will be mitigated through a TPP reliability project.

Table F.7-28: Charcot Sw Sta to Montague 115 kV Line on-peak Deliverability Constraint

Overloaded Facility	Contingency	Scenario	Loading	
			Base	Sensitivity
Charcot Sw Sta to Montague 115 kV Line	Los Esteros-Ringwood Sw Sta #1 115KV	HSN	100.18%	102.34%

Table F.7-29: Charcot Sw Sta to Montague 115 kV Line on-peak deliverability constraint summary

Affected transmission zones		Greater Bay Area	
		Base	Sensitivity
Portfolio resources behind the constraint (Installed FCDS capacity)		0	0
Generic portfolio battery storage behind the constraint (Installed FCDS capacity)		3	3
Deliverable portfolio resources w/o mitigation (Installed FCDS capacity)		0	0
Total undeliverable baseline and portfolio resources (Installed FCDS capacity)		23	96
Mitigation Options	RAS	N/A	
	Reduce generic battery storage (MW)	N/A	
	Transmission upgrade including cost	N/A	
Recommended Mitigation		The constraint will be mitigated through a TPP reliability project.	

### F.7.2. 2040 On-Peak Results

#### Tesla-Newark #2 230kV Line on-peak deliverability constraint

The deliverability of renewable portfolio resources in the Greater Bay area is limited by thermal overloading of the Tesla-Newark #2 230kV Line under NERC category P0 and P7 contingencies as shown in Table F.7-30. This constraint was identified in baseline portfolio under HSN conditions. As shown in Table F.7-31, 0 MW of renewable and energy storage would be deliverable without any transmission upgrades. The constraint will be mitigated through a TPP reliability project.

Table F.7-30: Tesla-Newark #2 230kV Line on-peak deliverability Constraint

Overloaded Facility	Contingency	Base Portfolio Loading	
		HSN	SSN
Tesla-Newark #2 230kV Line	Base Case	114.31%	<100
	Tesla-Newark #1 230kV & Tesla-Ravenswood 230kV	102.72%	<100

Table F.7-31: Tesla-Newark #2 230kV Line on-peak deliverability constraint summary

Affected transmission zones	Greater Bay Area	
	HSN	SSN
Portfolio resources behind the constraint (Installed FCDS capacity)	804	N/A
Generic portfolio battery storage behind the constraint (Installed FCDS capacity)	0	
Deliverable portfolio resources w/o mitigation (Installed FCDS capacity)	0	

Total undeliverable baseline and portfolio resources (Installed FCDS capacity)		828
Mitigation Options	RAS	N/A
	Reduce generic battery storage (MW)	N/A
	Transmission upgrade including cost	N/A
Recommended Mitigation		The constraint will be mitigated through a TPP reliability project.

Delta Switching Yard - Tesla 230 kV Line on-peak deliverability constraint

The deliverability of renewable portfolio resources in the Greater Bay area is limited by thermal overloading of the Delta Switching Yard - Tesla 230 kV Line under NERC category P7 contingency as shown in Table F.7-32. This constraint was identified in baseline portfolio under HSN conditions. As shown in Table F.7-33, 16 MW of renewable and energy storage would be deliverable without any transmission upgrades. The ISO will continue to monitor this constraint.

*Table F.7-32: Delta Switching Yard - Tesla 230 kV Line on-peak deliverability Constraint*

Overloaded Facility	Contingency	Base Portfolio Loading	
		HSN	SSN
Delta Switching Yard - Tesla 230 kV Line	Birds-CC PP 230 KV and Birds-CC Sub 230 KV lines	103.33%	<100

*Table F.7-33: Delta Switching Yard - Tesla 230 kV Line on-peak deliverability constraint summary*

Affected transmission zones		Greater Bay Area	
		HSN	SSN
Portfolio resources behind the constraint (Installed FCDS capacity)		21	N/A
Generic portfolio battery storage behind the constraint (Installed FCDS capacity)		93	
Deliverable portfolio resources w/o mitigation (Installed FCDS capacity)		16	
Total undeliverable baseline and portfolio resources (Installed FCDS capacity)		276	
Mitigation Options	RAS	N/A	
	Reduce generic battery storage (MW)	N/A	
	Transmission upgrade including cost	N/A	
Recommended Mitigation		Continue to Monitor	

Moraga-Castro Valley 230kV Line on-peak deliverability constraint

The deliverability of renewable portfolio resources in the Greater Bay area is limited by thermal overloading of the Moraga-Castro Valley 230kV Line under NERC category P1 contingency as shown in Table F.7-34. This constraint was identified in baseline portfolio under HSN conditions. As shown in Table F.7-35, 0 MW of renewable and energy storage would be deliverable without any transmission upgrades. The constraint will be mitigated through a TPP reliability project.

Table F.7-34: Moraga-Castro Valley 230kV Line on-peak deliverability constraint

Overloaded Facility	Contingency	Base Portfolio Loading	
		HSN	SSN
Moraga-Castro Valley 230kV Line	Las Positas-Newark 230 KV and North Dublin-Vineyard 230 KV lines	107.81%	<100

Table F.7-35: Moraga-Castro Valley 230kV Line on-peak deliverability constraint summary

Affected transmission zones		Greater Bay Area	
		HSN	SSN
Portfolio resources behind the constraint (Installed FCDS capacity)		248	N/A
Generic portfolio battery storage behind the constraint (Installed FCDS capacity)		65	
Deliverable portfolio resources w/o mitigation (Installed FCDS capacity)		0	
Total undeliverable baseline and portfolio resources (Installed FCDS capacity)		1737	
Mitigation Options	RAS	N/A	
	Reduce generic battery storage (MW)	N/A	
	Transmission upgrade including cost	N/A	
Recommended Mitigation		The constraint will be mitigated through a TPP reliability project.	

Tassajara-Newark 230kV Line on-peak deliverability constraint

The deliverability of renewable portfolio resources in the Greater Bay area is limited by thermal overloading of the Tassajara-Newark 230kV Line under NERC category P7 contingency as shown in Table F.7-36. This constraint was identified in baseline portfolio under HSN conditions. As shown in Table F.7-37, 0 MW of renewable and energy storage would be deliverable without any transmission upgrades. The constraint will be mitigated through a TPP reliability project.

Table F.7-36: Tassajara-Newark 230kV Line on-peak deliverability Constraint

Overloaded Facility	Contingency	Base Portfolio Loading	
		HSN	SSN
Tassajara-Newark 230kV Line	Tesla - Newark No.2 and Metcalf - Los Esteros 230 KV lines	108.48%	<100

Table F.7-37: Tassajara-Newark 230kV Line on-peak deliverability constraint summary

Affected transmission zones		Greater Bay Area	
		HSN	SSN
Portfolio resources behind the constraint (Installed FCDS capacity)		0	N/A
Generic portfolio battery storage behind the constraint (Installed FCDS capacity)		250	
Deliverable portfolio resources w/o mitigation (Installed FCDS capacity)		0	
Total undeliverable baseline and portfolio resources (Installed FCDS capacity)		406	
Mitigation Options	RAS	N/A	
	Reduce generic battery storage (MW)	N/A	
	Transmission upgrade including cost	N/A	
Recommended Mitigation		The constraint will be mitigated through a TPP reliability project.	

### Cayetano-Lone Tree (Lone Tree-USWP) 230kV Line on-peak deliverability constraint

The deliverability of renewable portfolio resources in the Greater Bay area is limited by thermal overloading of the Cayetano-Lone Tree (Lone Tree-USWP) 230kV Line under NERC category P0 and P7 contingencies as shown in Table F.7-38. This constraint was identified in baseline portfolio under HSN and SSN conditions. As shown in Table F.7-39, 0 MW of renewable and energy storage would be deliverable without any transmission upgrades. The ISO will continue to monitor this constraint.

Table F.7-38: Cayetano-Lone Tree (Lone Tree-USWP) 230kV Line on-peak deliverability Constraint

Overloaded Facility	Contingency	Base Portfolio Loading	
		HSN	SSN
Cayetano-Lone Tree (Lone Tree-USWP) 230kV Line	Base Case	109.78%	<100
	Tesla - Newark No.2 and Metcalf - Los Esteros 230 KV lines	122.16%	104.83%

Table F.7-39: Cayetano-Lone Tree (Lone Tree-USWP) 230kV Line on-peak deliverability constraint summary

Affected transmission zones		Greater Bay Area	
		HSN	SSN
Portfolio resources behind the constraint (Installed FCDS capacity)		143	143
Generic portfolio battery storage behind the constraint (Installed FCDS capacity)		65	65
Deliverable portfolio resources w/o mitigation (Installed FCDS capacity)		0	0
Total undeliverable baseline and portfolio resources (Installed FCDS capacity)		1373	501
Mitigation Options	RAS	N/A	
	Reduce generic battery storage (MW)	N/A	
	Transmission upgrade including cost	N/A	
Recommended Mitigation		Continue to Monitor	

Tesla D 500/230 kV Transformer on-peak deliverability constraint

The deliverability of renewable portfolio resources in the Greater Bay area is limited by thermal overloading of the Tesla D 500/230 kV Transformer under NERC category P0 and P7 contingencies as shown in Table F.7-40. This constraint was identified in baseline portfolio under HSN conditions. As shown in Table F.7-41, 179 MW of renewable and energy storage would be deliverable without any transmission upgrades. The ISO will continue to monitor this constraint.

Table F.7-40: Tesla D 500/230 kV Transformer on-peak deliverability Constraint

Overloaded Facility	Contingency	Base Portfolio Loading	
		HSN	SSN
Tesla D 500/230 kV Transformer	Base Case	100.41%	<100
	Tesla - Newark No.2 and Metcalf - Los Esteros 230 KV lines	105.33%	<100

Table F.7-41: Tesla D 500/230 kV Transformer on-peak deliverability constraint summary

Affected transmission zones		Greater Bay Area	
		HSN	SSN
Portfolio resources behind the constraint (Installed FCDS capacity)		1907	N/A
Generic portfolio battery storage behind the constraint (Installed FCDS capacity)		200	
Deliverable portfolio resources w/o mitigation (Installed FCDS capacity)		179	
Total undeliverable baseline and portfolio resources (Installed FCDS capacity)		1928	
Mitigation Options	RAS	N/A	
	Reduce generic battery storage (MW)	N/A	
	Transmission upgrade including cost	N/A	
Recommended Mitigation		Continue to Monitor	

### Oleum-Martinez 115kV Line on-peak deliverability constraint

The deliverability of renewable portfolio resources in the Greater Bay area is limited by thermal overloading of the Oleum-Martinez 115kV Line under NERC category P1 contingency as shown in Table F.7-42. This constraint was identified in baseline portfolio under HSN conditions. As shown in Table F.7-43, 547 MW of renewable and energy storage would be deliverable without any transmission upgrades. The constraint will be mitigated through the Oleum Area Reinforcement Project.

Table F.7-42: Oleum-Martinez 115kV Line on-peak deliverability Constraint

Overloaded Facility	Contingency	Base Portfolio Loading	
		HSN	SSN
Oleum-Martinez 115kV Line	North Tower-Martinez D 115KV	101.17%	<100

Table F.7-43: Oleum-Martinez 115kV Line on-peak deliverability constraint summary

Affected transmission zones		Greater Bay Area	
		HSN	SSN
Portfolio resources behind the constraint (Installed FCDS capacity)		0	N/A
Generic portfolio battery storage behind the constraint (Installed FCDS capacity)		577	
Deliverable portfolio resources w/o mitigation (Installed FCDS capacity)		547	
Total undeliverable baseline and portfolio resources (Installed FCDS capacity)		30	
Mitigation Options	RAS	N/A	
	Reduce generic battery storage (MW)	N/A	
	Transmission upgrade including cost	Oleum Area Reinforcement Project (\$82.78-\$144.29M)	
Recommended Mitigation		Oleum Area Reinforcement Project	

Pittsburg-San Mateo 230kV Line on-peak deliverability constraint

The deliverability of renewable portfolio resources in the Greater Bay area is limited by thermal overloading of the Pittsburg-San Mateo 230kV Line under NERC category P0 and P7 contingencies as shown in Table F.7-44. This constraint was identified in baseline portfolio under HSN and SSN conditions. As shown in Table F.7-45, 0 MW of renewable and energy storage would be deliverable without any transmission upgrades. This constraint can be mitigated by the East Shore 230kV Area Reinforcement Project.

Table F.7-44: Pittsburg-San Mateo 230kV Line on-peak deliverability Constraint

Overloaded Facility	Contingency	Base Portfolio Loading	
		HSN	SSN
Pittsburg-San Mateo 230kV Line	Base Case	100.77%	<100
	Newark-Ravenswood 230 KV and Tesla-Ravenswood 230 KV lines	119.8%	106.93%

Table F.7-45: Pittsburg-San Mateo 230kV Line on-peak deliverability constraint summary

Affected transmission zones		Greater Bay Area	
		HSN	SSN
Portfolio resources behind the constraint (Installed FCDS capacity)		0	0
Generic portfolio battery storage behind the constraint (Installed FCDS capacity)		1002	1002

Deliverable portfolio resources w/o mitigation (Installed FCDS capacity)		0	0
Total undeliverable baseline and portfolio resources (Installed FCDS capacity)		1678	1077
Mitigation Options	RAS	N/A	
	Reduce generic battery storage (MW)	N/A	
	Transmission upgrade including cost	East Shore 230kV Area Reinforcement Project (\$128.45M - \$256.9M)	
Recommended Mitigation		East Shore 230kV Area Reinforcement Project.	

North Dublin-Cayetano 230kV Cable on-peak deliverability constraint

The deliverability of renewable portfolio resources in the Greater Bay area is limited by thermal overloading of the North Dublin-Cayetano 230kV Cable under NERC category P7 contingency as shown in Table F.7-46. This constraint was identified in baseline portfolio under HSN conditions. As shown in Table F.7-47, 0 MW of renewable and energy storage would be deliverable without any transmission upgrades. The ISO will continue to monitor this constraint.

*Table F.7-46: North Dublin-Cayetano 230kV Cable on-peak deliverability Constraint*

Overloaded Facility	Contingency	Base Portfolio Loading	
		HSN	SSN
North Dublin-Cayetano 230kV Cable	Tesla - Newark No.2 and Metcalf - Los Esteros 230 KV lines	109.75%	<100

*Table F.7-47: North Dublin-Cayetano 230kV Cable on-peak deliverability constraint summary*

Affected transmission zones		Greater Bay Area	
		HSN	SSN
Portfolio resources behind the constraint (Installed FCDS capacity)		243	N/A
Generic portfolio battery storage behind the constraint (Installed FCDS capacity)		65	
Deliverable portfolio resources w/o mitigation (Installed FCDS capacity)		0	
Total undeliverable baseline and portfolio resources (Installed FCDS capacity)		392	
Mitigation Options	RAS	N/A	
	Reduce generic battery storage (MW)	N/A	
	Transmission upgrade including cost	N/A	
Recommended Mitigation		Continue to Monitor	

Eastshore 230/115kV Transformer #1 on-peak deliverability constraint

The deliverability of renewable portfolio resources in the Greater Bay area is limited by thermal overloading of the Eastshore 230/115kV Transformer #1 under NERC category P1 contingency as shown in Table F.7-48. This constraint was identified in baseline portfolio under HSN conditions. As shown in Table F.7-49, 0 MW of renewable and energy storage would be deliverable without any transmission upgrades. The ISO will continue to monitor this constraint.

Table F.7-48: Eastshore 230/115kV Transformer #1 on-peak deliverability Constraint

Overloaded Facility	Contingency	Base Portfolio Loading	
		HSN	SSN
Eastshore 230/115kV Transformer #1	E. SHORE 230/115KV TB 2	138.67%	<100

Table F.7-49: Eastshore 230/115kV Transformer #1 on-peak deliverability constraint summary

Affected transmission zones		Greater Bay Area	
		HSN	SSN
Portfolio resources behind the constraint (Installed FCDS capacity)		0	N/A
Generic portfolio battery storage behind the constraint (Installed FCDS capacity)		567	
Deliverable portfolio resources w/o mitigation (Installed FCDS capacity)		0	
Total undeliverable baseline and portfolio resources (Installed FCDS capacity)		1162	
Mitigation Options	RAS	N/A	
	Reduce generic battery storage (MW)	N/A	
	Transmission upgrade including cost	N/A	
Recommended Mitigation		Continue to Monitor	

Eastshore 230/115kV Transformer #2 on-peak deliverability constraint

The deliverability of renewable portfolio resources in the Greater Bay area is limited by thermal overloading of the Eastshore 230/115kV Transformer #2 under NERC category P1 contingency as shown in Table F.7-50. This constraint was identified in baseline portfolio under HSN conditions. As shown in Table F.7-51, 0 MW of renewable and energy storage would be deliverable without any transmission upgrades. The ISO will continue to monitor this constraint.

Table F.7-50: Eastshore 230/115kV Transformer #2 on-peak deliverability Constraint

Overloaded Facility	Contingency	Base Portfolio Loading	
		HSN	SSN
Eastshore 230/115kV Transformer #2	E. SHORE 230/115KV TB 1	137.5%	<100

Table F.7-51: Eastshore 230/115kV Transformer #2 on-peak deliverability constraint summary

Affected transmission zones		Greater Bay Area	
		HSN	SSN
Portfolio resources behind the constraint (Installed FCDS capacity)		0	N/A
Generic portfolio battery storage behind the constraint (Installed FCDS capacity)		567	
Deliverable portfolio resources w/o mitigation (Installed FCDS capacity)		0	
Total undeliverable baseline and portfolio resources (Installed FCDS capacity)		1143	
Mitigation Options	RAS	N/A	
	Reduce generic battery storage (MW)	N/A	
	Transmission upgrade including cost	N/A	
Recommended Mitigation		Continue to Monitor	

Pittsburg-Eastshore 230kV Line on-peak deliverability constraint

The deliverability of renewable portfolio resources in the Greater Bay area is limited by thermal overloading of the Pittsburg-Eastshore 230kV Line under NERC category P0 and P7 contingencies as shown in Table F.7-52. This constraint was identified in baseline portfolio under HSN and SSN conditions. As shown in Table F.7-53, 0 MW of renewable and energy storage would be deliverable without any transmission upgrades. This constraint can be mitigated by the East Shore 230kV Area Reinforcement Project.

Table F.7-52: Pittsburg-Eastshore 230kV Line on-peak deliverability Constraint

Overloaded Facility	Contingency	Base Portfolio Loading	
		HSN	SSN
Pittsburg-Eastshore 230kV Line	Base Case	107.02%	<100
	RUSTY EC CC PLANT	118.54%	102.85%

Table F.7-53: Pittsburg-Eastshore 230kV Line on-peak deliverability constraint summary

Affected transmission zones		Greater Bay Area	
		HSN	SSN
Portfolio resources behind the constraint (Installed FCDS capacity)		0	0
Generic portfolio battery storage behind the constraint (Installed FCDS capacity)		1002	1002
Deliverable portfolio resources w/o mitigation (Installed FCDS capacity)		0	0
Total undeliverable baseline and portfolio resources (Installed FCDS capacity)		1908	1038
Mitigation Options	RAS	N/A	
	Reduce generic battery storage (MW)	N/A	
	Transmission upgrade including cost	East Shore 230kV Area Reinforcement Project (\$128.45M - \$256.9M)	
Recommended Mitigation		East Shore 230kV Area Reinforcement Project.	

Las Positas-Newark 230kV Line on-peak deliverability constraint

The deliverability of renewable portfolio resources in the Greater Bay area is limited by thermal overloading of the Las Positas-Newark 230kV Line under NERC category P0 and P7 contingencies as shown in Table F.7-54. This constraint was identified in baseline portfolio under HSN and SSN conditions. As shown in Table F.7-55, 100 MW of renewable and energy storage would be deliverable without any transmission upgrades. The constraint will be mitigated through a TPP reliability project.

Table F.7-54: Las Positas-Newark 230kV Line on-peak deliverability Constraint

Overloaded Facility	Contingency	Base Portfolio Loading	
		HSN	SSN
Las Positas-Newark 230kV Line	Base Case	194.66%	176.21%
	Contra Costa-Moraga Nos. 1 & 2 230 KV lines	201.24%	189.93%

Table F.7-55: Las Positas-Newark 230kV Line on-peak deliverability constraint summary

Affected transmission zones		Greater Bay Area	
		HSN	SSN
Portfolio resources behind the constraint (Installed FCDS capacity)		243	243
Generic portfolio battery storage behind the constraint (Installed FCDS capacity)		65	65
Deliverable portfolio resources w/o mitigation (Installed FCDS capacity)		100	100

Total undeliverable baseline and portfolio resources (Installed FCDS capacity)		2949	2949
Mitigation Options	RAS	N/A	
	Reduce generic battery storage (MW)	N/A	
	Transmission upgrade including cost	N/A	
Recommended Mitigation		The constraint will be mitigated through a TPP reliability project.	

Los Esteros - Trimble 115 kV Line on-peak deliverability constraint

The deliverability of renewable portfolio resources in the Greater Bay area is limited by thermal overloading of the Los Esteros - Trimble 115 kV Line under NERC category P7 contingency as shown in Table F.7-56. This constraint was identified in baseline portfolio under HSN conditions. As shown in Table F.7-57, 0 MW of renewable and energy storage would be deliverable without any transmission upgrades. The constraint will be mitigated through a TPP reliability project.

Table F.7-56: Los Esteros - Trimble 115 kV Line on-peak deliverability Constraint

Overloaded Facility	Contingency	Base Portfolio Loading	
		HSN	SSN
Los Esteros - Trimble 115 kV line	Los Esteros - Montague 115 KV and Montague - Trimble 115 KV	111.89%	<100

Table F.7-57: Los Esteros - Trimble 115 kV Line on-peak deliverability constraint summary

Affected transmission zones		Greater Bay Area	
		HSN	SSN
Portfolio resources behind the constraint (Installed FCDS capacity)		0	N/A
Generic portfolio battery storage behind the constraint (Installed FCDS capacity)		103	
Deliverable portfolio resources w/o mitigation (Installed FCDS capacity)		0	
Total undeliverable baseline and portfolio resources (Installed FCDS capacity)		238	
Mitigation Options	RAS	N/A	
	Reduce generic battery storage (MW)	N/A	
	Transmission upgrade including cost	N/A	
Recommended Mitigation		The constraint will be mitigated through a TPP reliability project.	

Los Esteros - Nortech 115 kV Line on-peak deliverability constraint

The deliverability of renewable portfolio resources in the Greater Bay area is limited by thermal overloading of the Los Esteros - Nortech 115 kV Line under NERC category P7 contingency as shown in Table F.7-58. This constraint was identified in baseline portfolio under HSN conditions. As shown in Table F.7-59, 0 MW of renewable and energy storage would be deliverable without any transmission upgrades. The constraint will be mitigated through a TPP reliability project.

*Table F.7-58: Los Esteros - Nortech 115 kV Line on-peak deliverability Constraint*

Overloaded Facility	Contingency	Base Portfolio Loading	
		HSN	SSN
Los Esteros - Nortech 115 kV line	Los Esteros - Trimble & Los Esteros - Montague 115 KV	111.05%	<100

*Table F.7-59: Los Esteros - Nortech 115 kV Line on-peak deliverability constraint summary*

Affected transmission zones		Greater Bay Area	
		HSN	SSN
Portfolio resources behind the constraint (Installed FCDS capacity)		0	N/A
Generic portfolio battery storage behind the constraint (Installed FCDS capacity)		103	
Deliverable portfolio resources w/o mitigation (Installed FCDS capacity)		0	
Total undeliverable baseline and portfolio resources (Installed FCDS capacity)		194	
Mitigation Options	RAS	N/A	
	Reduce generic battery storage (MW)	N/A	
	Transmission upgrade including cost	N/A	
Recommended Mitigation		The constraint will be mitigated through a TPP reliability project.	

Metcalfe – Silver Creek Sw Sta #1 Line on-peak deliverability constraint

The deliverability of renewable portfolio resources in the Greater Bay area is limited by thermal overloading of the Metcalfe – Silver Creek Sw Sta #1 Line under NERC category P7 contingency as shown in Table F.7-60. This constraint was identified in baseline portfolio under HSN conditions. As shown in Table F.7-61, 28 MW of renewable and energy storage would be deliverable without any transmission upgrades. The ISO will continue to monitor this constraint.

*Table F.7-60: Metcalfe – Silver Creek Sw Sta #1 Line on-peak deliverability Constraint*

Overloaded Facility	Contingency	Base Portfolio Loading	
		HSN	SSN
Metcalfe – Silver Creek Sw Sta #1	Metcalfe - El Patio No. 1 & 2 115 KV Lines	106.13%	<100

*Table F.7-61: Metcalfe – Silver Creek Sw Sta #1 Line on-peak deliverability constraint summary*

Affected transmission zones		Greater Bay Area	
		HSN	SSN
Portfolio resources behind the constraint (Installed FCDS capacity)		0	N/A
Generic portfolio battery storage behind the constraint (Installed FCDS capacity)		327	
Deliverable portfolio resources w/o mitigation (Installed FCDS capacity)		28	
Total undeliverable baseline and portfolio resources (Installed FCDS capacity)		299	
Mitigation Options	RAS	N/A	
	Reduce generic battery storage (MW)	N/A	
	Transmission upgrade including cost	N/A	
Recommended Mitigation		Continue to Monitor	

Metcalfe – Silver Creek Sw Sta #2 Line on-peak deliverability constraint

The deliverability of renewable portfolio resources in the Greater Bay area is limited by thermal overloading of the Metcalfe – Silver Creek Sw Sta #2 Line under NERC category P7 contingency as shown in Table F.7-62. This constraint was identified in baseline portfolio under HSN conditions. As shown in Table F.7-63, 26 MW of renewable and energy storage would be deliverable without any transmission upgrades. This is a local constraint and the mitigation will be addressed through the generator interconnection process.

*Table F.7-62: Metcalfe – Silver Creek Sw Sta #2 Line on-peak deliverability Constraint*

Overloaded Facility	Contingency	Base Portfolio Loading	
		HSN	SSN
Metcalfe – Silver Creek Sw Sta #2	Metcalfe - El Patio No. 1 & 2 115 KV Lines	106.18%	<100

*Table F.7-63: Metcalfe – Silver Creek Sw Sta #2 Line on-peak deliverability constraint summary*

Affected transmission zones		Greater Bay Area	
		HSN	SSN
Portfolio resources behind the constraint (Installed FCDS capacity)		0	N/A
Generic portfolio battery storage behind the constraint (Installed FCDS capacity)		327	
Deliverable portfolio resources w/o mitigation (Installed FCDS capacity)		26	
Total undeliverable baseline and portfolio resources (Installed FCDS capacity)		301	
Mitigation Options	RAS	N/A	
	Reduce generic battery storage (MW)	N/A	
	Transmission upgrade including cost	N/A	
Recommended Mitigation		Continue to Monitor	

Bellota-Lockeford 230kV #1 Line on-peak deliverability constraint

The deliverability of renewable portfolio resources in the Greater Bay area is limited by thermal overloading of the Bellota-Lockeford 230kV #1 Line under NERC category P7 contingency as shown in Table F.7-64. This constraint was identified in baseline portfolio under HSN conditions. As shown in Table F.7-65, 240 MW of renewable and energy storage would be deliverable without any transmission upgrades. The ISO will continue to monitor this constraint.

*Table F.7-64: Bellota-Lockeford 230kV #1 Line on-peak deliverability Constraint*

Overloaded Facility	Contingency	Base Portfolio Loading	
		HSN	SSN
Bellota-Lockeford 230kV #1 line	Rio Oso-Lockeford 230Kv & Lockeford-Bellota 230Kv	109.79%	<100

*Table F.7-65: Bellota-Lockeford 230kV #1 Line on-peak deliverability constraint summary*

Affected transmission zones		Greater Bay Area	
		HSN	SSN
Portfolio resources behind the constraint (Installed FCDS capacity)		566	N/A
Generic portfolio battery storage behind the constraint (Installed FCDS capacity)		60	
Deliverable portfolio resources w/o mitigation (Installed FCDS capacity)		240	
Total undeliverable baseline and portfolio resources (Installed FCDS capacity)		845	
Mitigation Options	RAS	N/A	
	Reduce generic battery storage (MW)	N/A	
	Transmission upgrade including cost	N/A	
Recommended Mitigation		Continue to Monitor	

Bellota-Lockeford 230kV #2 Line on-peak deliverability constraint

The deliverability of renewable portfolio resources in the Greater Bay area is limited by thermal overloading of the Bellota-Lockeford 230kV #2 Line under NERC category P1 contingency as shown in Table F.7-66. This constraint was identified in baseline portfolio under HSN conditions. As shown in Table F.7-67, 385 MW of renewable and energy storage would be deliverable without any transmission upgrades. The ISO will continue to monitor this constraint.

Table F.7-66: Bellota-Lockeford 230kV #2 Line on-peak deliverability Constraint

Overloaded Facility	Contingency	Base Portfolio Loading	
		HSN	SSN
Bellota-Lockeford 230kV #2 line	Bellota-Lockford 230kV	105.66%	<100

Table F.7-67: Bellota-Lockeford 230kV #2 Line on-peak deliverability constraint summary

Affected transmission zones		Greater Bay Area	
		HSN	SSN
Portfolio resources behind the constraint (Installed FCDS capacity)		567	N/A
Generic portfolio battery storage behind the constraint (Installed FCDS capacity)		70	
Deliverable portfolio resources w/o mitigation (Installed FCDS capacity)		385	
Total undeliverable baseline and portfolio resources (Installed FCDS capacity)		1005	
Mitigation Options	RAS	N/A	
	Reduce generic battery storage (MW)	N/A	
	Transmission upgrade including cost	N/A	
Recommended Mitigation		Continue to Monitor	

Tesla - Westley 230 kV Line on-peak deliverability constraint

The deliverability of renewable portfolio resources in the Greater Bay area is limited by thermal overloading of the Tesla - Westley 230 kV Line under NERC category P1 contingency as shown in Table F.7-68. This constraint was identified in baseline portfolio under HSN conditions. As shown in Table F.7-69, 223 MW of renewable and energy storage would be deliverable without any transmission upgrades. The ISO will continue to monitor this constraint.

Table F.7-68: Tesla - Westley 230 kV Line on-peak deliverability Constraint

Overloaded Facility	Contingency	Base Portfolio Loading	
		HSN	SSN
Tesla - Westley 230 kV Line	Tesla 500/230KV TB 2	111.42%	<100

Table F.7-69: Tesla - Westley 230 kV Line on-peak deliverability constraint summary

Affected transmission zones		Greater Bay Area	
		HSN	SSN
Portfolio resources behind the constraint (Installed FCDS capacity)		1103	N/A
Generic portfolio battery storage behind the constraint (Installed FCDS capacity)		260	
Deliverable portfolio resources w/o mitigation (Installed FCDS capacity)		223	
Total undeliverable baseline and portfolio resources (Installed FCDS capacity)		1901	
Mitigation Options	RAS	N/A	
	Reduce generic battery storage (MW)	N/A	
	Transmission upgrade including cost	N/A	
Recommended Mitigation		Continue to Monitor	

Martinez-Noth Tower 115kv (Nrth twr to Alhamtp1 115kV)(New) Line on-peak deliverability constraint

The deliverability of renewable portfolio resources in the Greater Bay area is limited by thermal overloading of the Martinez-Noth Tower 115kv (Nrth twr to Alhamtp1 115kV)(New) Line on-peak deliverability constraint under NERC category P7 contingency as shown in Table F.7-70. This constraint was identified in baseline portfolio under HSN conditions. As shown in Table F.7-71, 47 MW of renewable and energy storage would be deliverable without any transmission upgrades. The constraint will be mitigated through the Oleum Area Reinforcement Project.

Table F.7-70: Martinez-Noth Tower 115kv (Nrth twr to Alhamtp1 115kV)(New) Line on-peak deliverability constraint

Overloaded Facility	Contingency	Base Portfolio Loading	
		HSN	SSN
Martinez-Noth Tower 115kv (Nrth twr to Alhamtp1 115kV)(New) Line	Pittsburg-Tidewater 230 KV and Pittsburg-Tesoro SW STA 230 KV lines	124.12%	<100

Table F.7-71: Martinez-Noth Tower 115kv (Nrth twr to Alhamtp1 115kv)(New) Line on-peak deliverability constraint summary

Affected transmission zones		Greater Bay Area	
		HSN	SSN
Portfolio resources behind the constraint (Installed FCDS capacity)		0	N/A
Generic portfolio battery storage behind the constraint (Installed FCDS capacity)		750	
Deliverable portfolio resources w/o mitigation (Installed FCDS capacity)		47	
Total undeliverable baseline and portfolio resources (Installed FCDS capacity)		703	
Mitigation Options	RAS	N/A	
	Reduce generic battery storage (MW)	N/A	
	Transmission upgrade including cost	Oleum Area Reinforcement Project (\$82.78-\$144.29M)	
Recommended Mitigation		Oleum Area Reinforcement Project	

### F.7.3. 2040 Tesla Out of State Wind Sensitivity Study

No new deliverability constraints were observed after modeling the Out of State wind resource at Tesla 500kV, compared to the 2040 HSN Baseline scenario (which did not have the OOS wind in-service). Certain constraints are worsened, and some see lower overloads (2-3% difference).

### F.7.4. 2040 Off-Peak Results

The off-peak deliverability constraints identified in the baseline portfolio assessment of the Greater Bay interconnection area, along with the recommended mitigation plans, are identified in Table F.7-72.

Table F.7-72: PG&E Greater Bay Interconnection Area Off-Peak deliverability constraints

Constraint	Contingency	Loading (%)	Renewable Portfolio MW behind Constraint	Energy Storage Portfolio MW behind Constraint	Renewable curtailment without mitigation	Potential Mitigation
Tesla 500/230kV Transformer #2	Base Case	102.26	1048	200	471	1072 MW Portfolio Battery dispatched in charging mode
Contra Costa-Contra Costa Sub 230kV Line	Birds Landing Sw Sta-Contra Costa PP 230kV	100.57	1394	670	11	12 MW Portfolio Battery dispatched in charging mode

Contra Costa - BDLSWSTA 230 kV Line	Birds Landing Sw Sta- Contra Costa Sub 230kV	101.35	1394	670	24	25 MW Portfolio Battery dispatched in charging mode
Bellota-Riverbank- Melones 115 kV Line	Bellota-Weber 230kV & Bellota-French Camp 230kV	128.41	1	211	91	175 MW Portfolio Battery dispatched in charging mode

### F.7.5. Conclusion and recommendation

The PGE Greater Bay area base and sensitivity portfolios deliverability assessment identified on-peak and off-peak constraints. As part of mitigation, ISO recommends the Pittsburg 230kV Reinforcement Project and the Oleum Area Reinforcement Project. Most of the other constraints will be mitigated through TPP reliability projects.

## F.8. PG&E Greater Fresno Interconnection Area

The total capacity of resources, by resource type, selected with Full Capacity Deliverability Status (FCDS) as well as those selected as Energy Only (EO) in the PG&E Greater Fresno interconnection area are listed in Table F.8-1. The portfolios in the interconnection area are comprised of solar, wind (in-state and offshore), battery storage, geothermal, biomass/biogas and distributed solar resources. All portfolio resources are modeled in policy-driven assessments except in the on-peak deliverability assessment in which only FCDS resources are modeled.

Table F.8-1: PG&E Greater Fresno Interconnection Area Base & Sensitivity Portfolios<sup>3</sup>

Resource Type	2035 Base Portfolio			2040 Base Portfolio			2035 Sensitivity Portfolio		
	FCDS (MW)	EO (MW)	Total (MW)	FCDS (MW)	EO (MW)	Total (MW)	FCDS (MW)	EO (MW)	Total (MW)
Solar	1,471	2,853	4,324	5,521	8,013	13,534	1,086	2,572	3,658
Wind – In State	491	70	561	491	70	561	321	50	371
Wind – Out-of-State	0	0	0	0	0	0	0	0	0
Wind - Offshore	0	0	0	0	0	0	0	0	0
Li Battery – 4 hr.	2,348	0	2,348	2,348	0	2,348	2,348	0	2,348
Li Battery – 8 hr.	700	0	700	2,765	0	2,765	35	0	35
Long Duration Energy Storage (LDES)	140	0	140	140	0	140	440	0	440
Geothermal	0	0	0	0	0	0	0	0	0
Biomass/Biogas	9	0	9	9	0	9	9	0	9
Distributed Solar	0	79	79	0	79	79	0	79	79
<b>Totals</b>	<b>5,159</b>	<b>3,002</b>	<b>8,161</b>	<b>11,274</b>	<b>8,162</b>	<b>19,436</b>	<b>4,239</b>	<b>2,701</b>	<b>6,940</b>

The resources as identified in the CPUC busbar mapping for the PG&E Greater Fresno interconnection area are illustrated on the single-line diagrams in Figure F.6-1, Figure F.8-2 and Figure F.8-3.

<sup>3</sup> Numbers include the adjustments to the base portfolio made by CPUC staff in the Greater Fresno Interconnection Area to account for allocated TPD, additional in-development resources identified and non-CPUC jurisdictional IRP plan resources.

Figure F.8-1: Greater Fresno Interconnection Area – Mapped 2035 Base Portfolio

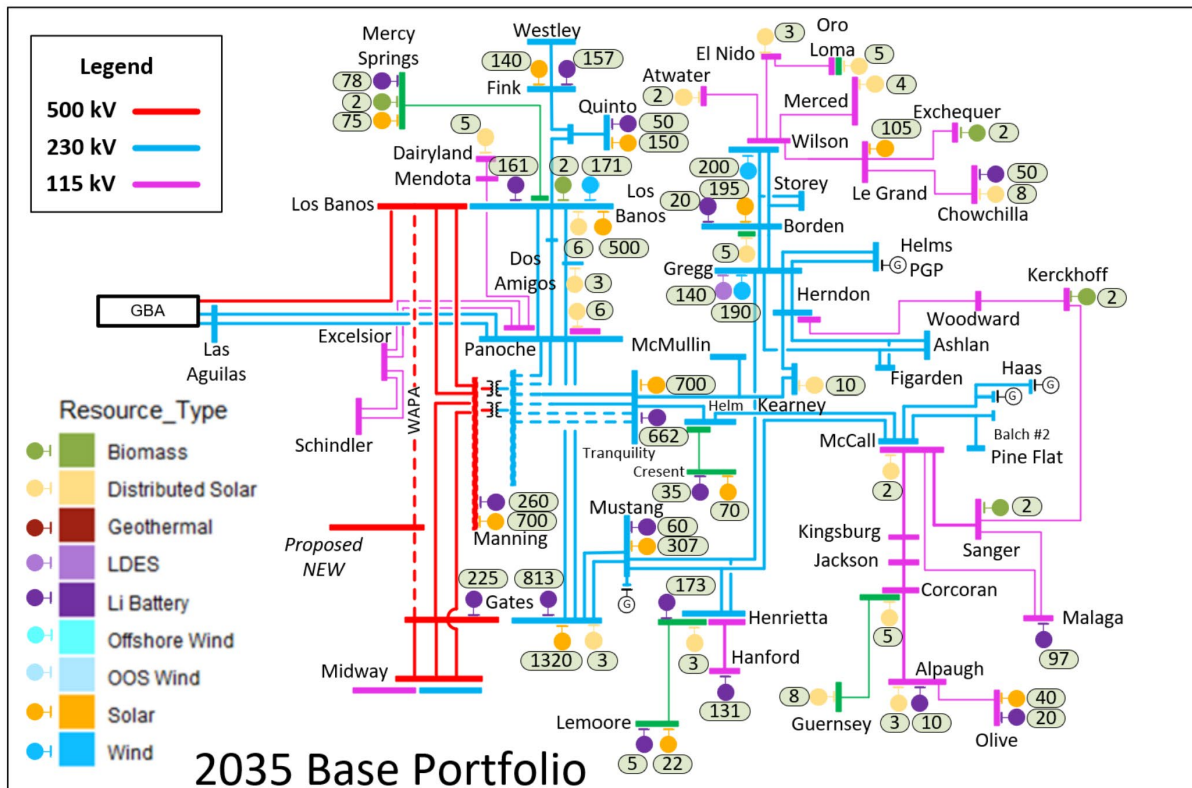

Figure F.8-2: Greater Fresno Interconnection Area – Mapped 2040 Base Portfolio

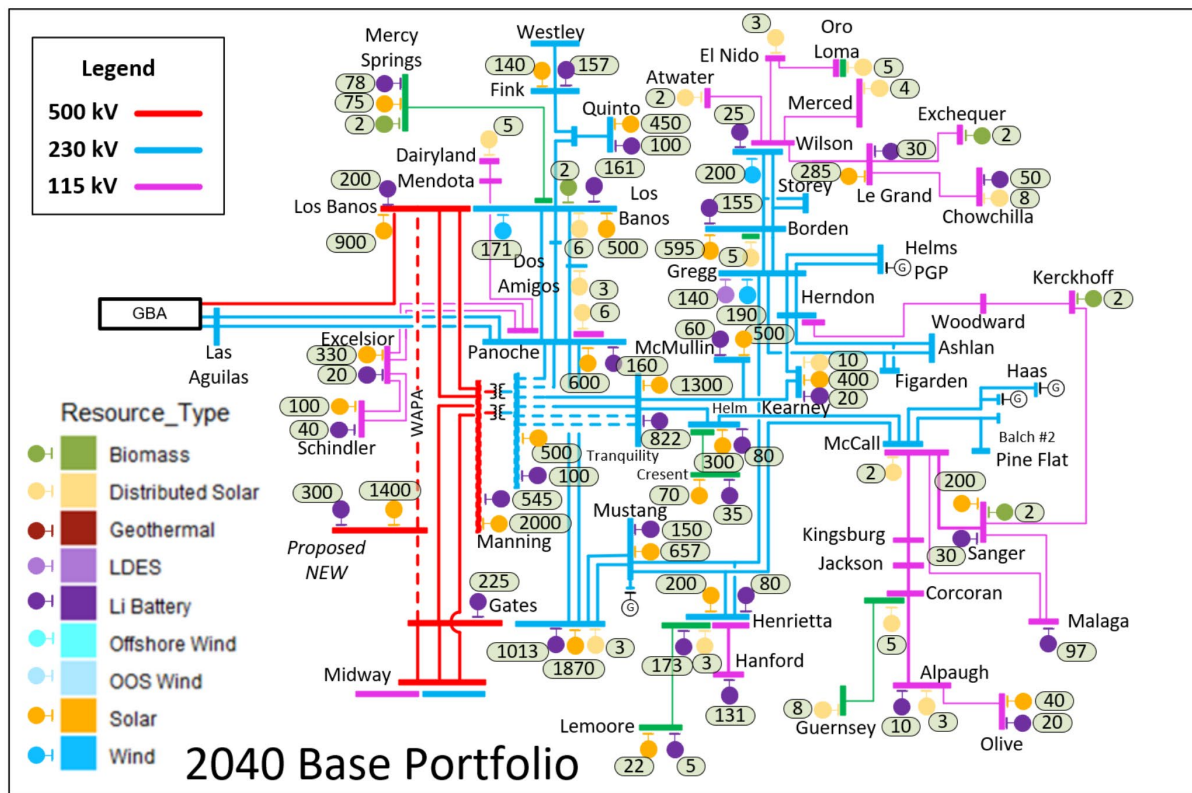



Table F.8-3: McCall-Sanger #3 115 kV Line on-peak deliverability constraint summary

Affected transmission zones		Greater Fresno Area	
		Base	Sensitivity
Portfolio resources behind the constraint (Installed FCDS capacity)		0	0
Generic portfolio battery storage behind the constraint (Installed FCDS capacity)		30	30
Deliverable portfolio resources w/o mitigation (Installed FCDS capacity)		0	0
Total undeliverable baseline and portfolio resources (Installed FCDS capacity)		36	75
Mitigation Options	RAS	N/A	
	Reduce generic battery storage (MW)	N/A	
	Transmission upgrade including cost	N/A	
Recommended Mitigation		Local constraint, will be addressed through the generator interconnection process	

Herndon-Woodward 115 kV Line on-peak deliverability constraint

The deliverability of renewable portfolio resources in the Greater Fresno area is limited by thermal overloading of the Herndon-Woodward 115 kV Line under NERC category P7 contingency as shown in Table F.8-4. This constraint was identified in baseline and sensitivity portfolios under HSN conditions. As shown in Table F.8-5, 0 MW of renewable and energy storage would be deliverable without any transmission upgrades. This is a local constraint and the mitigation will be addressed through the generator interconnection process.

Table F.8-4: Herndon-Woodward 115 kV Line on-peak deliverability constraint

Overloaded Facility	Contingency	Scenario	Loading	
			Base	Sensitivity
Herndon-Woodward 115 kV Line	Herndon-Barton 115 kV & Herndon-Manchester 115 kV	HSN	120.68%	115.85%

Table F.8-5: Herndon-Woodward 115 kV Line on-peak deliverability constraint summary

Affected transmission zones		Greater Fresno Area	
		Base	Sensitivity
Portfolio resources behind the constraint (Installed FCDS capacity)		405	140
Generic portfolio battery storage behind the constraint (Installed FCDS capacity)		20	20
Deliverable portfolio resources w/o mitigation (Installed FCDS capacity)		0	0
Total undeliverable baseline and portfolio resources (Installed FCDS capacity)		649	375

Mitigation Options	RAS	N/A
	Reduce generic battery storage (MW)	N/A
	Transmission upgrade including cost	N/A
Recommended Mitigation		Local constraint, will be addressed through the generator interconnection process

Crescent-Helm 70 kV Line on-peak deliverability constraint

The deliverability of renewable portfolio resources in the Greater Fresno area is limited by thermal overloading of the Crescent-Helm 70 kV under NERC category P7 contingency as shown in Table F.8-6. This constraint was identified in baseline and sensitivity portfolios under HSN conditions. As shown in Table F.8-7, 30 MW of renewable and energy storage would be deliverable without any transmission upgrades. This constraint is currently identified in and will be mitigated through an approved generator interconnection process network upgrade.

*Table F.8-6: Crescent-Helm 70 kV Line on-peak deliverability constraint*

Overloaded Facility	Contingency	Scenario	Loading	
			Base	Sensitivity
Crescent-Helm 70 kV Line	Tranquility SS-Helm #1 230 kV & Tranquility SS -Mcmullin1 #1 230 kV	HSN	107.11%	113.16%

*Table F.8-7: Crescent-Helm 70 kV on-peak deliverability constraint summary*

Affected transmission zones		Greater Fresno Area	
		Base	Sensitivity
Portfolio resources behind the constraint (Installed FCDS capacity)		40	35
Generic portfolio battery storage behind the constraint (Installed FCDS capacity)		0	0
Deliverable portfolio resources w/o mitigation (Installed FCDS capacity)		30	25
Total undeliverable baseline and portfolio resources (Installed FCDS capacity)		10	10
Mitigation Options	RAS	N/A	
	Reduce generic battery storage (MW)	N/A	
	Transmission upgrade including cost	N/A	
Recommended Mitigation		Generator Interconnection Process Approved Upgrade	

### F.8.2. 2040 On-Peak Results

#### McCall-Sanger #3 115 kV Line on-peak deliverability constraint

The deliverability of renewable portfolio resources in the Greater Fresno area is limited by thermal overloading of the McCall-Sanger #3 115 kV Line under NERC category P7 contingency as shown in Table F.8-8. This constraint was identified in baseline portfolio under HSN conditions. As shown in Table F.8-9, 0 MW of renewable and energy storage would be deliverable without any transmission upgrades. This is a local constraint and the mitigation will be addressed through the generator interconnection process.

*Table F.8-8: McCall-Sanger #3 115 kV Line on-peak Deliverability Constraint*

Overloaded Facility	Contingency	Base Portfolio Loading	
		HSN	SSN
McCall-Sanger #3 115 kV Line	McCall-Sanger #1 115 kV & McCall-Sanger #2 115 KV	105.05%	N/A

*Table F.8-9: McCall-Sanger #3 115 kV Line on-peak deliverability constraint summary*

Affected transmission zones		Greater Fresno Area	
		HSN	SSN
Portfolio resources behind the constraint (Installed FCDS capacity)		0	N/A
Generic portfolio battery storage behind the constraint (Installed FCDS capacity)		30	
Deliverable portfolio resources w/o mitigation (Installed FCDS capacity)		0	
Total undeliverable baseline and portfolio resources (Installed FCDS capacity)		101	
Mitigation Options	RAS	N/A	
	Reduce generic battery storage (MW)	N/A	
	Transmission upgrade including cost	N/A	
Recommended Mitigation		Local constraint, will be addressed through the generator interconnection process	

Herndon-Woodward 115 kV Line on-peak deliverability constraint

The deliverability of renewable portfolio resources in the Greater Fresno area is limited by thermal overloading of the Herndon-Woodward 115 kV Line under NERC category P7 contingency as shown in Table F.8-10. This constraint was identified in baseline portfolio under HSN and SSN conditions. As shown in Table F.8-11, 0 MW of renewable and energy storage would be deliverable without any transmission upgrades. This is a local constraint and the mitigation will be addressed through the generator interconnection process.

*Table F.8-10: Herndon-Woodward 115 kV Line on-peak deliverability constraint*

Overloaded Facility	Contingency	Base Portfolio Loading	
		HSN	SSN
Herndon-Woodward 115 kV Line	Herndon-Barton 115 kV & Herndon-Manchester 115 kV	127.87%	109.98%

*Table F.8-11: Herndon-Woodward 115 kV Line on-peak deliverability constraint summary*

Affected transmission zones		Greater Fresno Area	
		HSN	SSN
Portfolio resources behind the constraint (Installed FCDS capacity)		405	140
Generic portfolio battery storage behind the constraint (Installed FCDS capacity)		20	20
Deliverable portfolio resources w/o mitigation (Installed FCDS capacity)		0	0
Total undeliverable baseline and portfolio resources (Installed FCDS capacity)		649	375
Mitigation Options	RAS	N/A	
	Reduce generic battery storage (MW)	N/A	
	Transmission upgrade including cost	N/A	
Recommended Mitigation		Local constraint, will be addressed through the generator interconnection process	

Panoche-Schindler #2 115 kV Line on-peak deliverability constraint

The deliverability of renewable portfolio resources in the Greater Fresno area is limited by thermal overloading of the Panoche-Schindler #2 115 kV Line under NERC category P7 contingency as shown in Table F.8-12. This constraint was identified in baseline portfolio under HSN and SSN conditions. As shown in Table F.8-13, 442 MW of renewable and energy storage would be deliverable without any transmission upgrades. This is a local constraint and the mitigation will be addressed through the generator interconnection process.

Table F.8-12: Panoche-Schindler #2 115 kV Line on-peak deliverability constraint

Overloaded Facility	Contingency	Base Portfolio Loading	
		HSN	SSN
Panoche-Schindler #2 115 kV Line	Cantua-Excelsior SS 115 kV MOAS Opened on Panoche1_Kamm_Jct	104.62%	253.45%

Table F.8-13: Panoche-Schindler #2 115 kV Line on-peak deliverability constraint summary

Affected transmission zones		Greater Fresno Area	
		HSN	SSN
Portfolio resources behind the constraint (Installed FCDS capacity)		440	644
Generic portfolio battery storage behind the constraint (Installed FCDS capacity)		60	60
Deliverable portfolio resources w/o mitigation (Installed FCDS capacity)		442	321
Total undeliverable baseline and portfolio resources (Installed FCDS capacity)		58	403
Mitigation Options	RAS	N/A	
	Reduce generic battery storage (MW)	N/A	
	Transmission upgrade including cost	N/A	
Recommended Mitigation		Local constraint, will be addressed through the generator interconnection process	

Table F.8-14 lists constraints identified only in the SSN scenario. These are provided for informative purposes and mitigation is not required for this scenario.

Table F.8-14: Deliverability constraints identified only in SSN scenario

Constraint	Contingency	Loading	Renewable Portfolio MW behind Constraint	Energy Storage Portfolio MW behind Constraint	Deliverable Portfolio MW without mitigation	Total undeliverable baseline and portfolio MW	Potential Mitigation
Helm 230/70 kV Transformer #1	Helm 230/70 kV Transformer #2	123.07%	644	120	669	146	SSN Only, No Mitigation Required
Helm 230/70 kV Transformer #2	Helm 230/70 kV Transformer #1	123.08%	644	120	669	146	SSN Only, No Mitigation Required

### F.8.3. 2040 Off-Peak Results

The off-peak deliverability constraints identified in the baseline portfolio assessment of the Greater Fresno interconnection area, along with the recommended mitigation plans, are identified in Table F.8-15.

Table F.8-15: PG&E Greater Fresno Interconnection Area Off-Peak deliverability constraints

Constraint	Contingency	Loading (%)	Renewable Portfolio MW behind Constraint	Energy Storage Portfolio MW behind Constraint	Renewable curtailment without mitigation	Potential Mitigation
(New)Oro Loma-Mendota 115kV Line	Wilson-Borden 230kV #1 & #2 [9001]	100.05	2	0	0.8	Dispatch 3 MW portfolio battery resources in charging mode
Chowchilla-Kerckhoff #2 115 kV Line	Wilson-Le Grand 115kV [4170]	101.22	287	80	3	Dispatch 3 MW portfolio battery resources in charging mode
Coalinga #1-Coalinga #2 70 kV Line	Panoche-Schindler #1 115kV [3250] & Excelsiorss-Panoche2 115kV [3231]	130.36	465	60	110	Mitigation to be developed if economic
Excelsiorss-Schindlr #1 115kV Line	Panoche-Schindler #1 115kV [3250] & Excelsiorss-Panoche2 115kV [3231]	164.85	330	20	134	Mitigation to be developed if economic
Excelsiorss-Schindlr #2 115kV Line	Excelsiorss-Panoche1 115kV [3250] & Excelsiorss-Panoche2 115kV [3231]	156.79	330	20	133	Mitigation to be developed if economic
Gates-Huron 70 kV Line	Panoche-Schindler #1 115kV [3250] & Excelsiorss-Panoche2 115kV [3231]	149.18	465	60	156	Mitigation to be developed if economic
Le Grand-Chowchilla 115 kV Line	Wilson-Le Grand 115kV [4170]	111.26	287	30	25	Dispatch 25 MW portfolio battery resources in charging mode
Los Banos-Panoche #2 230 kV Line	Los Banos-Padre Flat Sw Sta 230kV [1092]	110.41	1034	220	426	Dispatch 676 MW portfolio battery resources in charging mode
Merced Falls-Exchequer 70 kV Line	Wilson-Le Grand 115kV [4170]	109.11	441	80	14	Dispatch 33 MW portfolio battery resources in charging mode
Merced-Merced Falls 70 kV Line	Wilson-Le Grand 115kV [4170]	101.8	287	80	3	Dispatch 7 MW portfolio battery resources in charging mode
Panoche 230/115 kV Transformer #2	Panoche1 115/230kV TB 1	118.07	1555	320	105	Dispatch 948 MW portfolio battery resources in charging mode
Panoche2-Excelsiorss 115kV Line	Panoche-Excelsior Sw Sta #1 115kV [3250] Moas Opened On Panoche1 Kamm Jct	263.64	465	60	300	Mitigation to be developed if economic

Panoche-Schindler #1 115 kV Line	Panoche-Excelsior Sw Sta #2 115kV [3260]	285.14	465	60	312	Mitigation to be developed if economic
Panoche-Schindler #2 115 kV Line	Panoche-Excelsior Sw Sta #1 115kV [3250] Moas Opened On Panoche1_Kamm_Jct	279.17	465	60	309	Mitigation to be developed if economic
Schindler 115/70 kV Transformer #1	Panoche-Schindler #1 115kV [3250] & Excelsiorss-Panoche2 115kV [3231]	423.87	430	60	312	Mitigation to be developed if economic
Schindler-Coalinga #2 70 kV Line	Panoche-Schindler #1 115kV [3250] & Excelsiorss-Panoche2 115kV [3231]	282.86	465	60	344	Mitigation to be developed if economic
Schindler-Huron-Gates 70 kV Line	Panoche-Schindler #1 115kV [3250] & Excelsiorss-Panoche2 115kV [3231]	347.63	850	120	352	Mitigation to be developed if economic
Wilson-Le Grand 115 kV Line	Wilson-Borden 230kV #1 & #2 [9001]	133.37	289	80	154	Mitigation to be developed if economic
Gates 500/230 kV #1	Gates-Panoche #1 230kV [4720] & Gates-Panoche #2 230kV [4730]	130.81	4013	1483	617	Dispatch 1252 MW portfolio battery resources in charging mode
Gates 500/230 kV #2	Gates 500/230kV TB 11	135.87	9440	2692	906	Dispatch 1180 MW portfolio battery resources in charging mode
Wilson – Melones 230kV Line	Helms-Gregg #1 230kV [4870] & Helms-Gregg #2 230kV [4880]	138.62	2026	310	1364	Mitigation to be developed if economic
Manning 500/230 kV #1	Manning 500/230kV TB 2	120.92	8639	2181	618	Dispatch 646 MW portfolio battery resources in charging mode
Manning 500/230 kV #2	Manning 500/230kV TB 1	120.92	8639	2181	618	Dispatch 646 MW portfolio battery resources in charging mode
Mustang Ss – Gates 230kV Line 1	Gates-Mustang Sw Sta #2 230kV [2605]	107.6	4221	777	90	Dispatch 1 MW portfolio battery resources in charging mode
Mustang Ss – Gates 230kV Line 2	Gates-Mustang Sw Sta #1 230kV [2604]	107.6	4221	777	90	Dispatch 1 MW portfolio battery resources in charging mode
Oro Loma - Poso J1 70kV Line 1	Panoche-Mendota 115kV [3230]	156.08	287	80	58	Mitigation to be developed if economic
Tomatak - Mendota 70kV Line 1	Panoche-Mendota 115kV [3230]	133.76	287	80	49	Mitigation to be developed if economic
Crescentss - SchIndlr 70 kV Line	Panoche-Schindler #1 115kV [3250] & Excelsiorss-Panoche2 115kV [3231]	363.91	430	60	306	Mitigation to be developed if economic
SchIndlr - Paigeslrjct 70kV Line	Panoche-Schindler #1 115kV [3250] & Excelsiorss-Panoche2 115kV [3231]	250.98	465	60	283	Mitigation to be developed if economic
Fivepoints Ss – Calflax 70kV Line 1	Panoche-Schindler #1 115kV [3250] & Excelsiorss-Panoche2 115kV [3231]	334.73	850	120	365	Mitigation to be developed if economic

### F.8.4. Conclusion and recommendation

The PGE Greater Fresno area base and sensitivity portfolios deliverability assessment identified on-peak and off-peak constraints. New transmission upgrades were not found to be needed in the area in the current planning cycle.

## F.9. PG&E Kern Interconnection Area

The total capacity of resources, by resource type, selected with Full Capacity Deliverability Status (FCDS) as well as those selected as Energy Only (EO) in the PG&E Kern interconnection area are listed in Table F.9-1. The portfolios in the interconnection area are comprised of solar, wind (in-state and offshore), battery storage, geothermal, biomass/biogas and distributed solar resources. All portfolio resources are modeled in policy-driven assessments except in the on-peak deliverability assessment in which only FCDS resources are modeled.

Table F.9-1: PG&E Kern Interconnection Area Base & Sensitivity Portfolios<sup>4</sup>

Resource Type	2035 Base Portfolio			2040 Base Portfolio			2035 Sensitivity Portfolio		
	FCDS (MW)	EO (MW)	Total (MW)	FCDS (MW)	EO (MW)	Total (MW)	FCDS (MW)	EO (MW)	Total (MW)
Solar	830	1,972	2,802	1,810	3,787	5,597	829	1,438	2,267
Wind – In State	113	0	113	113	0	113	113	0	113
Wind – Out-of-State	0	0	0	0	0	0	0	0	0
Wind - Offshore	2,924	0	2,924	2,924	0	2,924	4,875	0	4,875
Li Battery – 4 hr.	493	0	493	493	0	493	493	0	493
Li Battery – 8 hr.	410	0	410	1,210	0	1,210	0	0	0
Long Duration Energy Storage (LDES)	0	0	0	0	0	0	0	0	0
Geothermal	0	0	0	0	0	0	0	0	0
Biomass/Biogas	23	0	23	23	0	23	23	0	23
Distributed Solar	0	50	50	0	50	50	0	50	50
<b>Totals</b>	<b>4,793</b>	<b>2,022</b>	<b>6,815</b>	<b>6,573</b>	<b>3,837</b>	<b>10,410</b>	<b>6,333</b>	<b>1,488</b>	<b>7,821</b>

The resources as identified in the CPUC busbar mapping for the PG&E Kern interconnection area are illustrated on the single-line diagrams in Figure F.9-1, Figure F.9-2 and Figure F.9-3.

<sup>4</sup> Numbers include the adjustments to the base portfolio made by CPUC staff in the Kern Interconnection Area to account for allocated TPD, additional in-development resources identified and non-CPUC jurisdictional IRP plan resources.

Figure F.9-1: Kern Interconnection Area – Mapped 2035 Base Portfolio

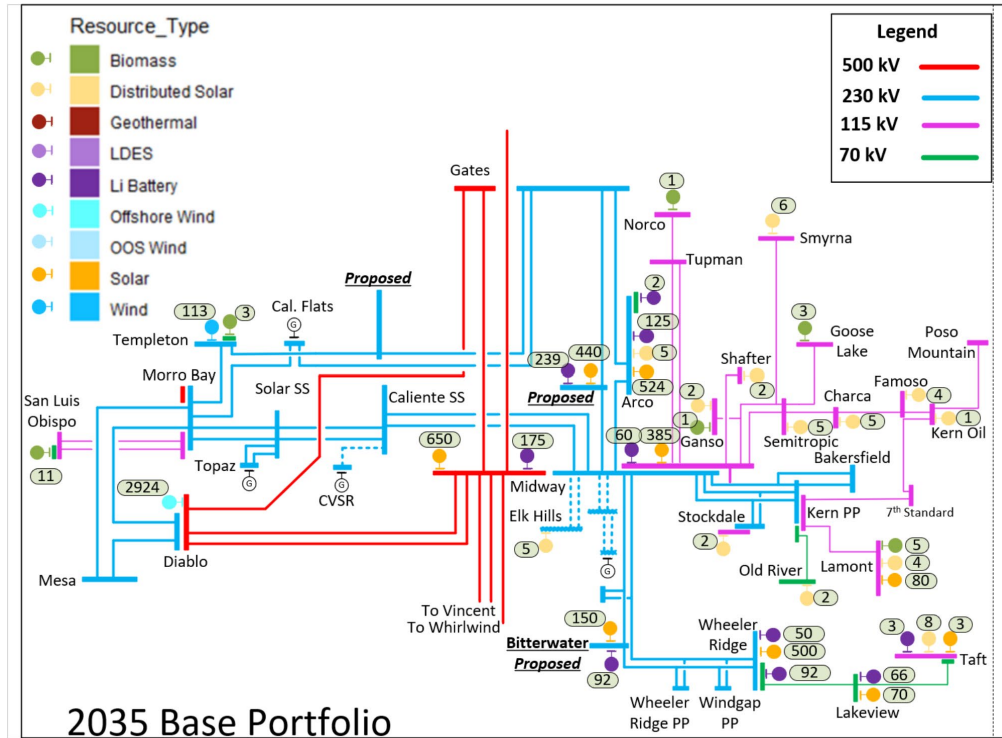

Figure F.9-2: Kern Interconnection Area – Mapped 2040 Base Portfolio

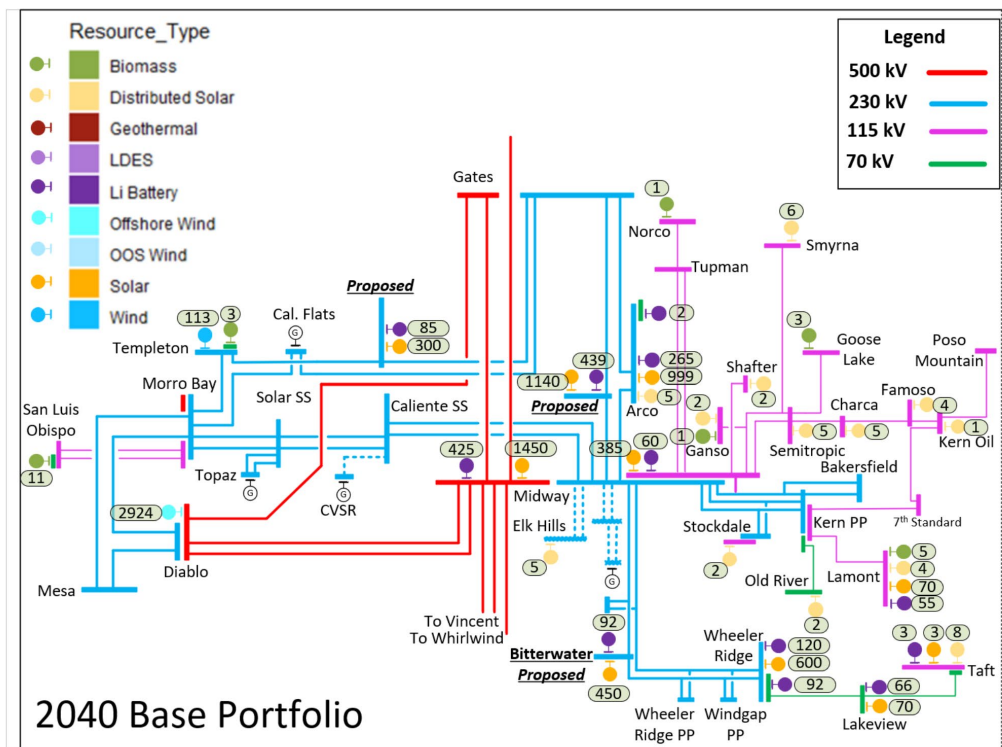
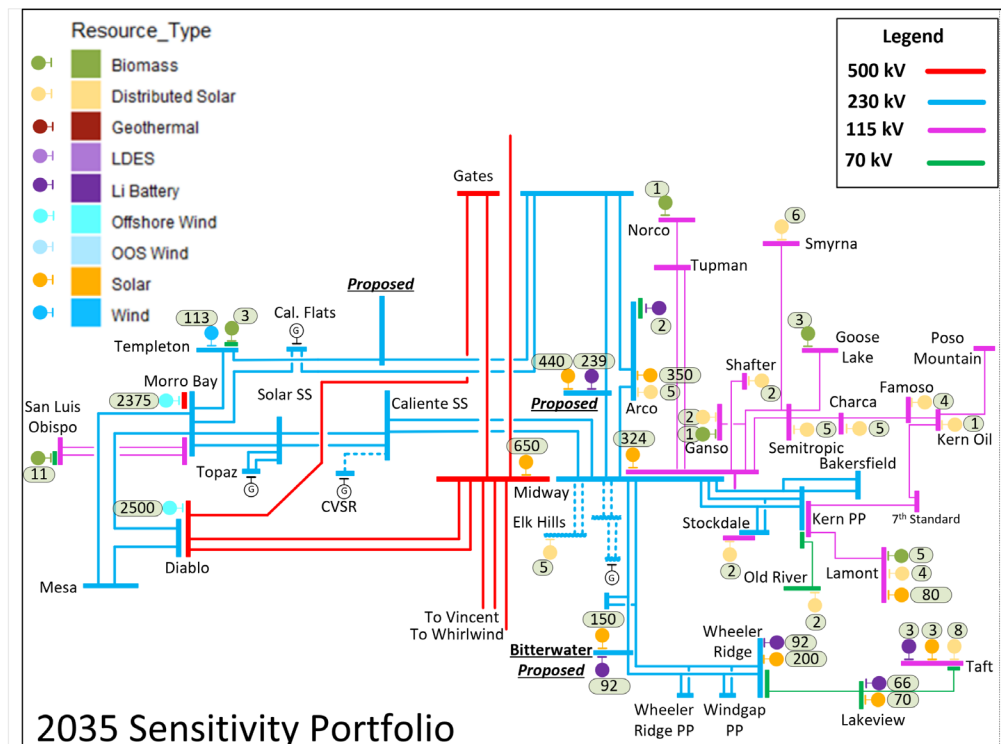

Figure F.9-3: Kern Interconnection Area – Mapped 2035 Sensitivity Portfolio



### F.9.1. 2035 On-Peak Results

#### Callender Sw. Sta-Mesa 115 kV Line on-peak deliverability constraint

The deliverability of renewable portfolio resources in the Kern area is limited by thermal overloading of the Callender Sw. Sta-Mesa 115 kV Line under NERC Category P1 contingency as shown in Table F.9-2. This constraint was identified in baseline and sensitivity portfolio under HSN conditions. As shown in Table F.9-3, 0 MW of renewable and energy storage would be deliverable without any transmission upgrades. This is a local constraint and will be addressed through the generator interconnection process.

Table F.9-2: Callender Sw. Sta-Mesa 115 kV Line on-peak deliverability constraint

Overloaded Facility	Contingency	Scenario	Loading	
			Base	Sensitivity
Callender Sw. Sta-Mesa 115 kV Line	Morro Bay 230/115KV TB 6	HSN	107.64%	108.26%

Table F.9-3: Callender Sw. Sta-Mesa 115 kV Line on-peak deliverability constraint summary

Affected transmission zones		Kern Area	
		Base	Sensitivity
Portfolio resources behind the constraint (Installed FCDS capacity)		0	0
Generic portfolio battery storage behind the constraint (Installed FCDS capacity)		125	125
Deliverable portfolio resources w/o mitigation (Installed FCDS capacity)		0	0
Total undeliverable baseline and portfolio resources (Installed FCDS capacity)		245	261
Mitigation Options	RAS	N/A	
	Reduce generic battery storage (MW)	N/A	
	Transmission upgrade including cost	N/A	
Recommended Mitigation		Local constraint, will be addressed through the generator interconnection process	

Oceano-Callender Sw. Sta 115 kV Line on-peak deliverability constraint

The deliverability of renewable portfolio resources in the Kern area is limited by thermal overloading of the Oceano-Callender Sw. Sta 115 kV Line under NERC Category P1 contingency as shown in Table F.9-4. This constraint was identified in baseline and sensitivity portfolio under HSN conditions. As shown in Table F.9-5, 0 MW of renewable and energy storage would be deliverable without any transmission upgrades. This is a local constraint and will be addressed through the generator interconnection process.

Table F.9-4: Oceano-Callender Sw. Sta 115 kV Line on-peak deliverability constraint

Overloaded Facility	Contingency	Scenario	Loading	
			Base	Sensitivity
Oceano-Callender Sw. Sta 115 kV Line	Morro Bay 230/115KV TB 6	HSN	108.8%	109.42%

Table F.9-5: Oceano-Callender Sw. Sta 115 kV Line on-peak deliverability constraint summary

Affected transmission zones		Kern Area	
		Base	Sensitivity
Portfolio resources behind the constraint (Installed FCDS capacity)		0	0
Generic portfolio battery storage behind the constraint (Installed FCDS capacity)		125	125
Deliverable portfolio resources w/o mitigation (Installed FCDS capacity)		0	0

Total undeliverable baseline and portfolio resources (Installed FCDS capacity)		285	302
Mitigation Options	RAS	N/A	
	Reduce generic battery storage (MW)	N/A	
	Transmission upgrade including cost	N/A	
Recommended Mitigation		Local constraint, will be addressed through the generator interconnection process	

### F.9.2. 2040 On-Peak Results

#### Mesa-Santa Maria 115 kV Line on-peak deliverability constraint

The deliverability of renewable portfolio resources in the Kern area is limited by thermal overloading of the Mesa-Santa Maria 115 kV Line under NERC Category P7 contingencies as shown in Table F.9-6. This constraint was identified in baseline portfolio under HSN and SSN conditions. As shown in Table F.9-7, 0 MW of renewable and energy storage would be deliverable without any transmission upgrades. This is a local constraint and will be addressed through the generator interconnection process.

*Table F.9-6: Mesa-Santa Maria 115 kV Line on-peak deliverability constraint*

Overloaded Facility	Contingency	Base Portfolio Loading	
		HSN	SSN
Mesa-Santa Maria 115 kV Line	Morro Bay-San Luis Obispo #1 and #2 115 kV Lines	104.68%	N/A
	Mesa-Sisquoc and Callender Sw Sta-Mesa 115 kV Lines	N/A	104.2%

*Table F.9-7: Mesa-Santa Maria 115 kV Line on-peak deliverability constraint summary*

Affected transmission zones		Kern Area	
		HSN	SSN
Portfolio resources behind the constraint (Installed FCDS capacity)		0	330
Generic portfolio battery storage behind the constraint (Installed FCDS capacity)		265	0
Deliverable portfolio resources w/o mitigation (Installed FCDS capacity)		0	0
Total undeliverable baseline and portfolio resources (Installed FCDS capacity)		314	343
Mitigation Options	RAS	N/A	
	Reduce generic battery storage (MW)	N/A	
	Transmission upgrade including cost	N/A	

Recommended Mitigation	Local constraint, will be addressed through the generator interconnection process
------------------------	---

Table F.9-8 lists constraints identified only in the SSN scenario. These are provided for informative purposes and mitigation is not required for this scenario.

Table F.9-8: Deliverability constraints identified only in SSN scenario

Constraint	Contingency	Loading	Renewable Portfolio MW behind Constraint	Energy Storage Portfolio MW behind Constraint	Deliverable Portfolio MW without mitigation	Total undeliverable baseline and portfolio MW	Potential Mitigation
Callender Sw. Sta-Mesa 115 kV Line	Morro Bay 230/115kV TB 6	105.37	330	265	305	290	SSN Only, No Mitigation Required
Oceano-Callender Sw. Sta 115 kV Line	Morro Bay 230/115kV TB 6	106.65	330	265	197	398	SSN Only, No Mitigation Required

### F.9.3. 2040 Off-Peak Results

The off-peak deliverability constraints identified in the baseline portfolio assessment of the Kern interconnection area, along with the recommended mitigation plans, are identified in Table F.9-9.

Table F.9-9: PG&E Kern Interconnection Area Off-Peak deliverability constraints

Constraint	Contingency	Loading (%)	Renewable Portfolio MW behind Constraint	Energy Storage Portfolio MW behind Constraint	Renewable curtailment without mitigation	Potential Mitigation
Estrella-Calflats SS 230 kV Line	Templeton-Gates 230kV	110.89	1426	360	124	Dispatch 123 MW portfolio battery resources in charging mode
Morro Bay-Estrella 230kV Line	Templeton-Gates 230kV	108.77	1426	360	104	Dispatch 106 MW existing battery resources in charging mode
Morro Bay-Solars 230 kV No. 1	Templeton-Gates 230kV [5934] & Gates-Calflats SS #1 230kV	110.89	1426	360	104	Dispatch 106 MW existing battery resources in charging mode
Morro Bay-Solars 230 kV No. 2	Templeton-Gates 230kV [5934] & Gates-Calflats SS #1 230kV	110.89	1426	360	104	Dispatch 106 MW existing battery resources in charging mode
Morro Bay-Diablo 230 kV Line	Morro Bay-Mesa And Diablo-Mesa 230 kV Lines	186.03	999	265	362	Mitigate, if also beneficial in economic studies
Morro Bay-Mesa 230 kV Line	Morro Bay-Diablo 230kV	126.15	1010	275	147	Dispatch 41 MW portfolio and 106 MW existing battery resources in charging mode
Midway-Cahte SS 230 kV Line 1	Templeton-Gates 230kV [5934] & Gates-Calflats SS #1 230kV	104.59	1426	360	71	Dispatch 85 MW existing battery resources in charging mode

Midway-Cante SS 230 kV Line 2	Templeton-Gates 230kV [5934] & Gates-Calflats SS #1 230kV	104.59	1426	360	71	Dispatch 85 MW existing battery resources in charging mode
Diablo-Mesa 230 kV Line	Morro Bay-Diablo 230kV	196.72	999	265	407	Mitigation to be developed if economic
Wheeler Ridge-Lamont 115 kV Line	Kern-Tevis-Stockdale-Lamont & Kern-Tevis-Stockdale 115 kV Lines	171.74	205	55	107	Mitigation to be developed if economic
Temblor-San Luis Obispo 115 kV Line	Templeton-Gates 230kV [5934] & Gates-Calflats SS #1 230kV	154.91	1426	360	443	Dispatch 336 MW portfolio and 106 MW existing battery resources in charging mode
San Luis Obispo-Santa Maria 115 kV Line	Morro Bay-Diablo 230kV	107.49	999	275	42	Dispatch 52 MW existing battery resources in charging mode
Callender Sw. Sta-Mesa 115 kV Line	Morro Bay-Diablo 230kV	118.29	999	275	117	Dispatch 20 MW portfolio and 106 MW existing battery resources in charging mode
Oceano-Callender Sw. Sta 115 kV Line	Morro Bay-Diablo 230kV	114.02	999	275	88	Dispatch 97 MW existing battery resources in charging mode
Paso Robles-Templeton 70 kV Line	Morro Bay-Calflats SS And Templeton-Gates 230 kV Lines	146.2	1426	360	372	Dispatch 321 MW portfolio and 106 MW existing battery resources in charging mode
Coalinga #1-San Miguel 70 kV Line	Templeton-Gates 230kV [5934] & Gates-Calflats SS #1 230kV	240.07	1426	360	874	Mitigation to be developed if economic
Union Tap – Paso Robles 70kV Line	Morro Bay-Calflats SS And Templeton-Gates 230 kV Lines	135	1426	360	268	Dispatch 210 MW portfolio and 106 MW existing battery resources in charging mode

### F.9.4. Conclusion and recommendation

The PG&E Kern interconnection area baseline and sensitivity portfolio deliverability assessment identified on-peak and off-peak constraints. New transmission upgrades were not found to be needed in the area in the current planning cycle.

## F.10. East of Pisgah area

The total capacity of resources, by resource type, selected with Full Capacity Deliverability Status (FCDS) as well as those selected as Energy Only (EO) in the East of Pisgah interconnection area are listed in Table F.10-1. The portfolios in the interconnection area are comprised of solar, wind (in-state and out-of-state), battery storage and geothermal resources. All portfolio resources are modeled in policy-driven assessments except in the on-peak deliverability assessment in which only FCDS resources are modeled.

*Table F.10-1: East of Pisgah Interconnection Area – Base and Sensitivity Portfolios<sup>5</sup> by Resource Types (FCDS, EO and Total)*

Resource Type	2035 Base Portfolio			2040 Base Portfolio			2035 Sensitivity Portfolio		
	FCDS (MW)	EO (MW)	Total (MW)	FCDS (MW)	EO (MW)	Total (MW)	FCDS (MW)	EO (MW)	Total (MW)
Solar	781	1617	2,398	1,666	4,332	5,998	1,161	1,008	2,169
Wind – In State	1,052	177	1,229	1,052	177	1,229	860	50	910
Wind – Out-of-State	4,151	0	4,151	4,151	0	4,151	4,006	0	4,006
Wind - Offshore	0	0	0	0	0	0	0	0	0
Li Battery – 4 hr	3,871	0	3,871	2,730	0	2,730	4,107	0	4,107
Li Battery – 8 hr	320	0	320	1,590	0	1,590	0	0	0
Long Duration Energy Storage (LDES)	0	0	0	0	0	0	0	0	0
Geothermal	517	0	517	517	0	517	678	0	678
Biomass/Biogas	0	0	0	0	0	0	0	0	0
Distributed Solar	0	0	0	0	0	0	0	0	0
<b>Total</b>	<b>10,692</b>	<b>1,794</b>	<b>12,486</b>	<b>11,706</b>	<b>4,509</b>	<b>16,215</b>	<b>10,812</b>	<b>1,058</b>	<b>11,870</b>

The resources as identified in the CPUC busbar mapping for the East of Pisgah interconnection area are illustrated on the single-line diagrams below.

<sup>5</sup> Numbers include the adjustments to the base portfolio made by CPUC staff in the East of Pisgah Interconnection Area to account for allocated TPD, additional in-development resources identified and non-CPUC jurisdictional IRP plan resources.

Figure F.10-1: East of Pisgah Interconnection Area – Mapped 2035 Base Portfolio

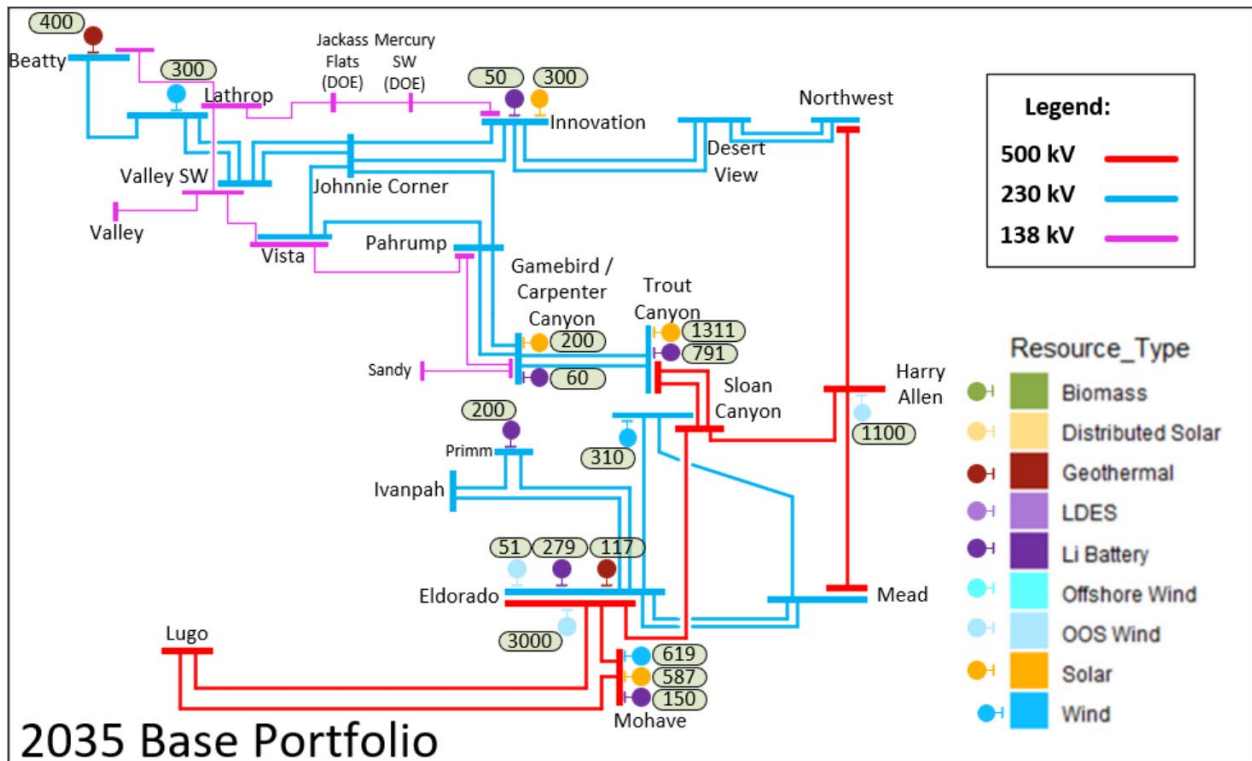

Figure. 10-2: East of Pisgah Interconnection Area – Mapped 2040 Base Portfolio

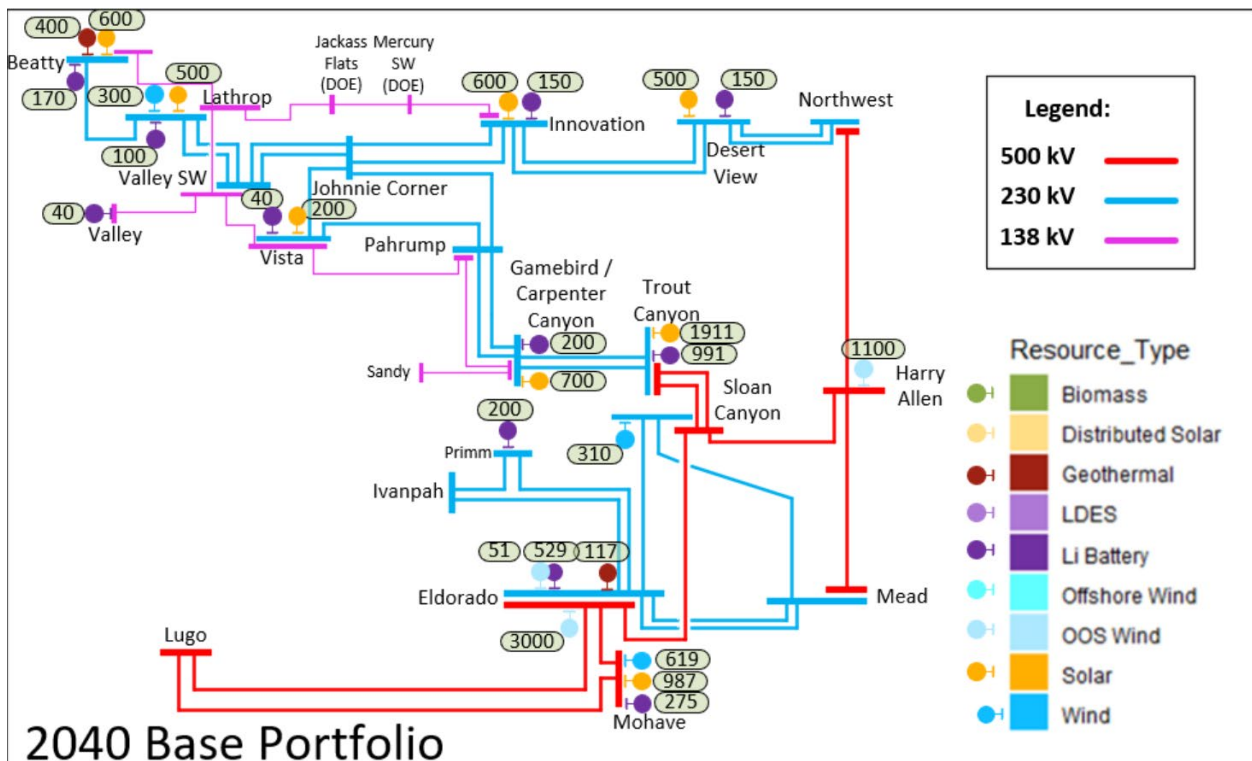
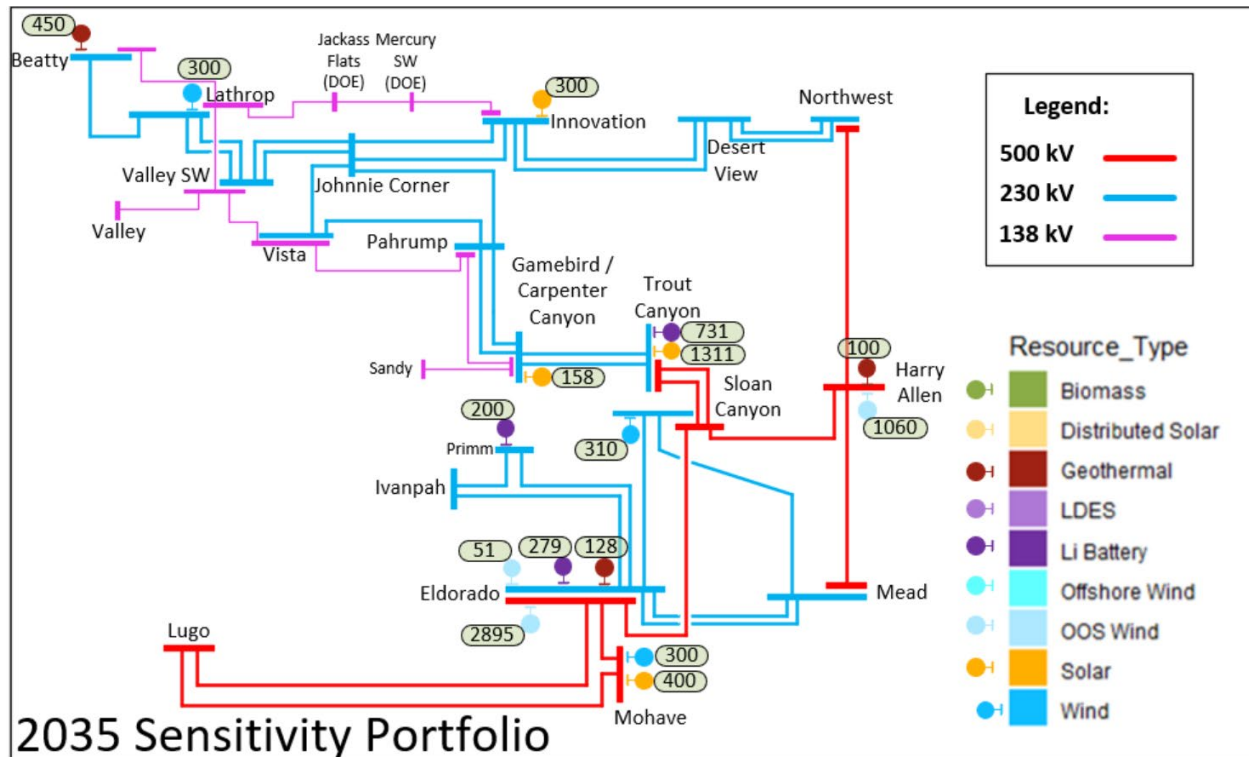

Figure.10-3: East of Pisgah Interconnection Area – Mapped 2035 Sensitivity Portfolio



### F.10.1. 2035 On-peak results

#### GLW-VEA Area Constraint

The deliverability of full capacity portfolio resources in the VEA and GLW area is limited by thermal overloading of multiple 138 kV and 230 kV facilities following Category P7 contingencies as shown in Table F.10-2. This constraint was identified in 2035 baseline and sensitivity portfolios under HSN condition. As shown in Table F.10-3, 2,952 MW of renewable and energy storage resources are behind the constraint and 1,809 MW are undeliverable in 2035 baseline portfolio. In 2035 sensitivity portfolio, 3,104 MW of resources are behind the constraint and 1,845 MW are undeliverable.

Table F.10-2: VEA-GLW 2034 on-peak deliverability constraints

Overloaded Facility	Contingency	Loading (%)	
		Base	Sensitivity
Sandy – Amargosa 138kV line	Trout Canyon – Sloan Canyon 500kV Nos. 1&2 lines	195	198
Gamebird 230/138kV transformer		148	148
Innovation – Northwest 138kV tie line		144	148
Gamebird – Sandy 138kV line		130	132
Amargosa 230/138kV transformer		113	114
Innovation – Northwest 138kV tie line	Desert View – Northwest 230kV Nos.1&2 lines	131	139

Table F.10-3: VEA-GLW 2035 on-peak constraint summary

Affected transmission zones		GLW, VEA	
		Base	Sensitivity
Portfolio resources behind the constraint (Installed FCDS capacity)		2,952 MW	3,104 MW
Generic portfolio battery storage behind the constraint (Installed FCDS capacity)		120 MW	0 MW
Deliverable portfolio resources w/o mitigation (Installed FCDS capacity)		1,143 MW	1,259 MW
Total undeliverable baseline and portfolio resources (Installed FCDS capacity)		1,809 MW	1,845 MW
Mitigation Options	RAS	Not sufficient	
	Reduce generic battery storage (MW)	Not sufficient	
	Grid Enhancing Technology	Not applicable	
	Transmission upgrade including cost	1. Trout Canyon – Lugo 500kV line (\$2.5 B) 2. Sagebrush Interconnection (\$204 M)	
Recommended Mitigation		Trout Canyon – Lugo 500kV line	

The future Sloan Canyon RAS (aka Trout Canyon RAS) as proposed in the GIDAP process will not be sufficient. Relocating generic portfolio battery storage will not be applicable since this area interacts with MIC to import out-of-state wind resource and there is already certain amount of unaccounted for TPD added to the study. Generic portfolio battery storage mapped substations are largely consistent with queue projects interconnection substations. Relocating generic portfolio battery storage will result in that amount of battery storage capacity being converted to unaccounted for TPD and will not reduce total resources behind the constraint. Two transmission upgrades were studied as potential

mitigation options. For detailed analysis, please refer to section F.10.2. 2040 On-peak results.

Lugo – Victorville 500 kV Constraint

The deliverability of full capacity portfolio resources in the East of Pisgah, SCE Eastern, SCE Northern and SDG&E areas and the deliverability of out-of-state wind resources is limited by thermal overloading of Lugo – Victorville 500 kV lines following Category P1 contingency as shown in Table F.10-4. This constraint was identified in 2035 baseline and sensitivity portfolios under HSN condition. As mentioned earlier, the 1,500 MW of Wyoming wind mapped to Eldorado and the 1,750 MW of New Mexico wind mapped to Lugo that require additional out of state transmission solutions were excluded in the base and sensitivity portfolios analysis. As shown in Table F.10-5, 15,924 MW of renewable and energy storage resources are behind the constraint, and 5,130 MW would be undeliverable in 2035 baseline portfolio. In 2035 sensitivity portfolio, 15,974 MW are behind the constraint, and 5,025 MW are not deliverable. MIC expansion request on the MEAD\_ITC and PALOVRDE\_ITC interties are behind this constraint and the 665.2 MW MIC expansion request in 2035 baseline portfolio and 770.2 MW in 2035 sensitivity portfolio are not deliverable. Three transmission alternatives were evaluated as potential mitigation options. For detailed analysis, please refer to Section F.10.2.

*Table F.10-4: Lugo - Victorville 500 kV 2035 on-peak deliverability constraints*

Overloaded Facility	Contingency	Loading (%)	
		Base	Sensitivity
Lugo – Victorville 500kV line	Base Case	106	103
	Eldorado – Lugo 500kV line	122	118
	Lugo – Mohave 500kV line	114	109
	Eldorado – Mohave 500kV line	101	<100
Eldorado – Lugo 500kV line	Lugo – Victorville 500kV line	105	104

Table F.10-5: Lugo – Victorville 500 kV 2035 on-peak constraint summary

Affected transmission zones		East of Pisgah, SCE Eastern, SCE Northern, SDG&E
		Base                      Sensitivity
Portfolio resources behind the constraint (Installed FCDS capacity)		15,924 MW                      15,974 MW
Generic portfolio battery storage behind the constraint (Installed FCDS capacity)		259 MW                      88 MW
Deliverable portfolio resources w/o mitigation (Installed FCDS capacity)		10,794 MW                      10,949 MW
Total undeliverable baseline and portfolio resources (Installed FCDS capacity)		5,130 MW                      5,025 MW
Mitigation Options	RAS	Not sufficient
	Reduce generic battery storage (MW)	Not applicable
	Grid Enhancing Technology	TBD
	Transmission upgrade including cost	1. Trout Canyon-Lugo 500kV line (\$2.5 B) 2. Eldorado-Lugo 500kV No.2 line (\$2.5 B) 3. Marketplace-Adelanto AC-DC conversion (\$1.1 B)
Recommended Mitigation		Trout Canyon – Lugo 500kV line

Affected interties	MEAD_ITC, PALOVRDE_ITC	
	Base	Sensitivity
MIC expansion request MW behind constraint	665.2 MW	770.2 MW
Deliverable MIC expansion request MW	0	0

Eldorado - McCullough 500 kV Constraint

The deliverability of full capacity portfolio resources in the East of Pisgah area and the deliverability of out-of-state wind resources is limited by thermal overloading of Eldorado - McCullough 500 kV line following Category P1 contingencies as shown in Table F.10-6. This constraint was identified in 2035 baseline and sensitivity portfolios under HSN condition. As shown in Table F.10-7, 9,343 MW of renewable and energy storage resources are behind the constraint and 3,282 MW are undeliverable in 2035 baseline portfolio. In 2035 sensitivity portfolio, 9,614 MW of resources are behind the constraint and 3,841 MW are undeliverable. MIC expansion request on the MEAD\_ITC intertie is behind this constraint, and the 114 MW MIC expansion request is undeliverable in both baseline and sensitivity

portfolios. A few alternatives were evaluated to mitigate the constraint, please refer to section F.10.2 for detailed assessment. The final mitigation plan will be coordinated with Eldorado 500 kV SCD mitigation and the transmission upgrade to accommodate the out-of-state wind portfolio.

Table F.10-6: Eldorado - McCullough 500 kV 2035 on-peak deliverability constraints

Overloaded Facility	Contingency	Loading (%)	
		Base	Sensitivity
Eldorado – McCullough 500 kV line	Eldorado – Lugo 500 kV line	124	128
	Lugo – Mohave 500 kV line	110	111

Table F.10-7: Eldorado - McCullough 500 kV 2035 on-peak constraint summary

Affected transmission zones		East of Pisgah	
		Base	Sensitivity
Portfolio resources behind the constraint (Installed FCDS capacity)		9,343 MW	9,614 MW
Generic portfolio battery storage behind the constraint (Installed FCDS capacity)		320 MW	0
Deliverable portfolio resources w/o mitigation (Installed FCDS capacity)		6,061 MW	5,773 MW
Total undeliverable baseline and portfolio resources (Installed FCDS capacity)		3,282 MW	3,841 MW
Mitigation Options	RAS	Not sufficient	
	Reduce generic battery storage (MW)	Not applicable	
	Grid Enhancing Technology	10 Ohms series reactor on Eldorado-McCullough line	
	Transmission upgrade	1. Trout Canyon-Lugo 500kV line (\$2.5 B) 2. Eldorado-Lugo 500kV No.2 line (\$2.5 B) 3. Marketplace-Adelanto AC-DC conversion (\$1.1 B) 4. Sloan Canyon-Marketplace 500kV line (\$49M)	
Recommended Mitigation		Trout Canyon – Lugo 500kV line	

Affected interties	MEAD_ITC	
	Base	Sensitivity
MIC expansion request MW behind constraint	114 MW	114 MW
Deliverable MIC expansion request MW	0	0

### F.10.2. 2040 On-peak results

#### GLW-VEA Area Constraint

The deliverability of full capacity portfolio resources in the VEA and GLW area is limited by thermal overloading of multiple 138 kV and 230 kV facilities following Category P7 contingencies as shown in Table F.10-8. This constraint was identified under both HSN and SSN scenarios. Table F.10-9 summarizes the renewable and energy storage resources behind the constraint and the undeliverable resources under both scenarios.

Table F.10-8: GLW-VEA 2040 on-peak deliverability constraints

Overloaded Facility	Contingency	Base Portfolio Loading (%)	
		HSN	SSN
Sandy – Amargosa 138kV line	Trout Canyon – Sloan Canyon 500kV Nos.1&2 lines	212	201
Innovation – Northwest 138kV tie line		203	158
Gamebird 230/138kV transformer		176	145
Gamebird – Sandy 138kV line		140	134
Amargosa 230/138kV transformer		122	115
Innovation – Northwest 138kV tie line	Northwest – Desert View 230kV Nos.1&2 lines	137	124
	Innovation – Desert View 230kV Nos.1&2 lines	107	106

Table F.10-9: GLW-VEA 2040 on-peak constraint summary

Affected transmission zones		GLW, VEA	
		HSN	SSN
Portfolio resources behind the constraint (Installed FCDS capacity)		4,222 MW	
Generic portfolio battery storage behind the constraint (Installed FCDS capacity)		916 MW	
Deliverable portfolio resources w/o mitigation (Installed FCDS capacity)		1,975 MW	2,639 MW
Total undeliverable baseline and portfolio resources (Installed FCDS capacity)		2,247 MW	1,583 MW
Mitigation Options	RAS	Not sufficient	
	Reduce generic battery storage (MW)	Not applicable	
	Grid Enhancing Technology	Not applicable	

	Transmission upgrade including cost	1. Trout Canyon-Lugo 500kV line (\$2.5 B) 2. Sagebrush Interconnection (\$204 M)
Recommended Mitigation		Trout Canyon – Lugo 500kV line

Two transmission upgrades were studied as potential mitigation options. Sagebrush Interconnection project was a request window submittal by GLW. The project will install approximately 25 miles of 230 kV line between Beatty and the new planned NVE Sagebrush substations using the future Lathrop Wells – Beatty 230 kV double circuit capable structure; and install a new 500/230 kV transformer at Sagebrush substation. While the project could mitigate the Innovation – Northwest 138 kV tie line following Northwest – Desert View 230 kV Nos.1&2 and Innovation – Desert View 230 kV Nos.1&2 lines P7 contingencies, it cannot mitigate the overloads on Sandy – Amargosa and Gamebird – Sandy 138 kV lines and Gamebird 230/138 kV transformer following Trout Canyon – Sloan Canyon 500 kV No.1&2 lines P7 contingency, and around 980 MW resources need to be curtailed. The Sloan Canyon RAS identified in GIDAP process can be utilized to mitigate those three overloads.

While the Sagebrush Interconnection project is effective in reducing the GLW-VEA area constraint, it has little impact on reducing the Sloan Canyon – Eldorado, Eldorado – McCullough and Lugo – Victorville constraints. Additional transmission upgrades are needed.

Another alternative is to build a new Trout Canyon – Lugo 500 kV line with series compensation. The Trout Canyon – Lugo 500 kV line is found to be able to mitigate all the identified overloads in GLW-VEA area. However, with 2040 baseline portfolio, a minor 4% overload on Pahrump – Gamebird 138 kV line is observed following loss of Gamebird – Wheeler Pass (Pahrump) 230 kV Nos.1&2 lines. About 30 MW resources need to be curtailed. We will monitor this overload in future studies and propose RAS when necessary.

Lugo – Victorville 500 kV Constraint

The deliverability of full capacity portfolio resources in the East of Pisgah, SCE Eastern, SCE Northern and SDG&E areas and the deliverability of out-of-state wind resources are limited by the thermal overloading of Lugo – Victorville 500 kV line as shown in Table F.10-10. This constraint was identified under both HSN and SSN scenarios. Table F.10-11 summarizes the renewable and battery resources behind the constraint and the undeliverable resources for both scenarios. MIC expansion requests on the MEAD\_ITC and PALOVRDE

\_ITC interties are behind this constraint and the 665.2 MW of MIC expansion requests are undeliverable.

Table F.10-10: Lugo – Victorville 500 kV 2040 on-peak deliverability constraints

Overloaded Facility	Contingency	Base Portfolio Loading (%)	
		HSN	SSN
Lugo – Victorville 500kV line	Base case	116	101
	Eldorado – Lugo 500kV line	133	117
	Lugo – Mohave 500kV line	124	106
	Eldorado – Mohave 500kV line	111	<100
Eldorado – Lugo 500kV line	Lugo – Victorville 500kV line	116	107
	Lugo – Mohave 500kV line	102	<100

Table F.10-11: Lugo – Victorville 500 kV 2040 on-peak constraint summary

Affected transmission zones		East of Pisgah, SCE Eastern, SCE Northern, SDG&E	
		HSN	SSN
Portfolio resources behind the constraint (Installed FCDS capacity)		17,574 MW	
Generic portfolio battery storage behind the constraint (Installed FCDS capacity)		1,969 MW	
Deliverable portfolio resources w/o mitigation (Installed FCDS capacity)		10,359 MW	12,838 MW
Total undeliverable baseline and portfolio resources (Installed FCDS capacity)		7,215 MW	4,736 MW
Mitigation Options	RAS	Not applicable	
	Reduce generic battery storage (MW)	Not sufficient	
	Grid Enhancing Technology	Not applicable	
	Transmission upgrade including cost	1.Trout Canyon-Lugo 500kV line (\$2.5 B) 2.Eldorado-Lugo 500kV No.2 line (\$2.5 B) 3.Marketplace-Adelanto AC-DC conversion (\$1.1 B)	
Recommended Mitigation		Trout Canyon – Lugo 500kV line	

Affected interties	MEAD_ITC, PALOVRDE_ITC
MIC expansion request MW behind constraint	665.2 MW
Deliverable MIC expansion request MW	0

Three transmission upgrades were studied as potential mitigations. For the Marketplace – Adelanto AC-DC conversion project, the study assumed an 1,800 MW capacity increase to the existing MAP path available to the ISO. However, the ISO has not been able to obtain evidence that 1800 MW would be available to the ISO if this project were to proceed. A variation of this project with 1000 MW available to the ISO was also studied and discussed in section F.10.5. All three alternatives were found to be sufficient to mitigate all the overloads listed in Table F.10.2-3 and eliminate the use of Lugo – Victorville RAS. With Eldorado – Lugo 500 kV No.2 line and the Marketplace – Adelanto AC-DC conversion projects, the worst contingency loading on Lugo – Victorville 500 kV line is reduced to below 90%. With Trout Canyon – Lugo 500 kV line, the worst contingency loading on Lugo – Victorville 500 kV line is reduced to 98%.

Eldorado - McCullough 500 kV Constraint

The deliverability of full capacity portfolio resources of in the East of Pisgah area and the deliverability of out-of-state wind resources is limited by thermal overloading of Eldorado - McCullough and Victorville – McCullough Nos.1 & 2 500 kV lines following Category P1 contingencies as shown in Table F.10-12. This constraint was identified under both HSN and SSN scenarios. Table F.10-13 summarizes the renewable and battery resources behind the constraint and the undeliverable resources under both scenarios. MIC expansion request on the MEAD\_ITC intertie is behind this constraint, and the 114 MW MIC expansion request is undeliverable.

*Table F.10-12: Eldorado - McCullough 500 kV 2040 on-peak deliverability constraints*

Overloaded Facility	Contingency	Loading (%)	
		HSN	SSN
Eldorado – McCullough 500 kV line	Eldorado – Lugo 500 kV line	141	131
	Lugo – Mohave 500 kV line	123	108
Victorville – McCullough 500 kV Nos.1&2 lines	Base Case	102	100
	Eldorado – Lugo 500 kV line	112	107
	Lugo – Mohave 500 kV line	103	<100

Table F.10-13: Eldorado – McCullough 500 kV 2040 on-peak constraint summary

Affected transmission zones		East of Pisgah	
		HSN	SSN
Portfolio resources behind the constraint (Installed FCDS capacity)		10,346 MW	
Generic portfolio battery storage behind the constraint (Installed FCDS capacity)		1,591 MW	
Deliverable portfolio resources w/o mitigation (Installed FCDS capacity)		5,976 MW	5,973 MW
Total undeliverable baseline and portfolio resources (Installed FCDS capacity)		4,370 MW	4,373 MW
Mitigation Options	RAS	Not sufficient	
	Reduce generic battery storage (MW)	Not sufficient	
	Grid Enhancing Technology	10 Ohms series reactor on Eldorado-McCullough line	
	Transmission upgrade including cost	1. Trout Canyon-Lugo 500kV line (\$2.5 B) 2. Eldorado-Lugo 500kV No.2 line (\$2.5 B) 3. Marketplace-Adelanto AC-DC conversion (\$1.1 B) 4. Sloan Canyon-Marketplace 500kV line (\$49 M)	
Recommended Mitigation		Trout Canyon – Lugo 500kV line	

Affected interties	MEAD_ITC
MIC expansion request MW behind constraint	114 MW
Deliverable MIC expansion request MW	0

A few alternatives including grid enhancing technology and transmission upgrades are evaluated for their effectiveness. The Sloan Canyon – Marketplace 500 kV line was submitted by GLW as request window submittal. The project would install an approximately 1.5 miles 500 kV line between Sloan Canyon substation and LADWP’s Marketplace substation with at least 3464 MVA summer emergency rating. While the project could mitigate the Eldorado – McCullough constraint, an outage of Sloan Canyon – Eldorado 500 kV line could overload the new Sloan Canyon – Marketplace 500 kV line and approximately 1,100 MW generation would need to be curtailed.

The other three transmission upgrade alternatives and the 10 Ohms series reactor option are all found to be sufficient to mitigate the Eldorado – McCullough constraint without any adverse impact.

Sloan Canyon – Eldorado 500 kV Constraint

The deliverability of full capacity portfolio resources in the East of Pisgah area and the deliverability of out-of-state wind resources is limited by thermal overloading of Sloan Canyon – Eldorado 500 kV line as shown in Table F.10-14. This constraint was identified under HSN scenario only. Table F.10-15 summarizes the renewable and battery resources behind the constraint and the undeliverable resources under both scenarios. MIC expansion request on the MEAD\_ITC intertie is behind this constraint and the 114 MW MIC expansion request is undeliverable.

There are three potential mitigation options and all of them are found to be effective in mitigating the constraint.

*Table F.10-14: Sloan Canyon – Eldorado 500 kV 2040 on-peak deliverability constraints*

Overloaded Facility	Contingency	Loading (%)	
		HSN	SSN
Sloan Canyon – Eldorado 500 kV line	Base Case	109	<100

*Table F.10-15: Sloan Canyon – Eldorado 500 kV 2040 on-peak constraint summary*

Affected transmission zones		East of Pisgah		
		HSN	SSN	
Portfolio resources behind the constraint (Installed FCDS capacity)		8,705 MW	N/A	
Generic portfolio battery storage behind the constraint (Installed FCDS capacity)		1,316 MW		
Deliverable portfolio resources w/o mitigation (Installed FCDS capacity)		7,721 MW		
Total undeliverable baseline and portfolio resources (Installed FCDS capacity)		984 MW		
Mitigation Options	RAS	Not applicable		
	Reduce generic battery storage (MW)	generic battery is co-located with solar		
	Grid Enhancing Technology	TBD		
	Transmission upgrade including cost	1.Second Sloan Canyon-Eldorado 500kV line (\$100 M) 2.Sloan Canyon-Marketplace 500kV line (\$49 M) 3.Trout Canyon-Lugo 500kV line (\$2.5 B)		
Recommended Mitigation		Trout Canyon – Lugo 500kV line		

Affected interties	MEAD_ITC
MIC expansion request MW behind constraint	114 MW
Deliverable MIC expansion request MW	0

### F.10.3. 2040 Off-peak results

Wind and solar resources in the East of Pisgah area are subject to curtailment in the base portfolio due to loading constraints identified in Table F.10-16 under normal and/or contingency conditions.

Table F.10-16: EOP area off-peak deliverability constraints

Overloaded Facility	Contingency	Loading (%)
Amargosa-Sandy 138kV line	Trout Canyon-Sloan Canyon 500kV Nos.1&2 lines	281
Innovation-Northwest 138kV tie line		194
Amargosa 230/138kV transformer		162
Gamebird 230/130kV transformer		159
Northwest-Desert View 230kV No.1		112
Northwest-Desert View 230kV No.2		114
Innovation-Desert View 230kV No.1		103
Innovation-Desert View 230kV No.2		103
Innovation-Northwest 138kV tie line	Northwest-Desert View 230kV Nos.1&2 lines	197
Amargosa-Sandy 138kV line		134
Innovation 230/138kV transformer		107
Amargosa-Sandy 138kV line	Gamebird-Trout Canyon 230kV Nos.1&2 lines	160
Sandy-Gamebird 138kV line		105
Amargosa-Sandy 138kV line	Innovation-Johnnie 230kV Nos.1&2 lines	103
Gamebird-Pahrump 138kV line	Gamebird-Wheeler Pass 230kV Nos.1&2 lines	112
Sloan Canyon-Eldorado 500kV line	Base Case	108
Eldorado-McCullough 500kV line	Eldorado-Lugo 500kV line	124
	Lugo-Mohave 500kV line	113
	Harry Allen-Mead 500kV line	102
	Northwest-Desert View 230kV Nos.1&2 lines	102
	Harry Allen-Muddy & Harry Allen-Mead 500kV lines	101

### GLW-VEA Area Constraint

About 2,136 MW wind and solar resources in VEA and GLW area are subject to curtailment to prevent overloads on multiple 138 kV and 230 kV facilities following several category P7 contingencies. Alternatively, the overloads can be mitigated by charging 1,884 MW portfolio energy storage in addition to charging all baseline battery storage. The recommended mitigation for off-peak scenario is to charge portfolio energy storage.

Table F.10-17: VEA-GLW off-peak deliverability constraint summary

Affected renewable transmission zones		GLW, VEA
Portfolio solar and wind resources behind the constraint		5,186 MW
Portfolio energy storage behind the constraint		2,437 MW
Renewable curtailment without mitigation		2,136 MW
Mitigation Options:	Portfolio ES (in charging mode)	1,884 MW
	RAS	Not sufficient
	Grid Enhancing Technology	Not applicable
	Transmission upgrades	Refer to on-peak analysis
Recommended Mitigation		Charging portfolio energy storage

### Sloan Canyon – Eldorado 500 kV Constraint

About 500 MW wind and solar resources in East of Pisgah area are subject to curtailment to prevent base case overload on Sloan Canyon – Eldorado 500 kV line. Alternatively, the overload can be mitigated by charging 260 MW portfolio energy storage in addition to charging all baseline battery storage. The recommended mitigation for off-peak scenario is to charge portfolio energy storage.

Table F.10-18: Sloan Canyon – Eldorado 500kV off-peak deliverability constraint summary

Affected renewable transmission zones		East of Pisgah
Portfolio solar and wind resources behind the constraint		5,496 MW
Portfolio energy storage behind the constraint		3,297 MW
Renewable curtailment without mitigation		500 MW
Mitigation Options:	Portfolio ES (in charging mode)	260 MW
	RAS	Not applicable
	Grid Enhancing Technology	TBD
	Transmission upgrades	Refer to on-peak analysis
Recommended Mitigation		Charging portfolio energy storage

### Eldorado - McCullough 500 kV Constraint

About 1,550 MW wind and solar resources in East of Pisgah area are subject to curtailment to prevent Eldorado – McCullough 500 kV line overloads following multiple category P1

contingencies. Alternatively, the overloads can be mitigated by charging 1,299 MW portfolio energy storage in addition to charging all baseline battery storage. The recommended mitigation for off-peak scenario is to charge portfolio energy storage.

Table F.10-19: Eldorado – McCullough 500kV off-peak deliverability constraint summary

Affected renewable transmission zones		East of Pisgah
Portfolio solar and wind resources behind the constraint		7,101 MW
Portfolio energy storage behind the constraint		4,352 MW
Renewable curtailment without mitigation		1,550 MW
Mitigation Options:	Portfolio ES (in charging mode)	1,299 MW
	RAS	Not sufficient
	Grid Enhancing Technology	TBD
	Transmission upgrades	Refer to on-peak analysis
Recommended Mitigation		Charging portfolio energy storage

### F.10.4. Wyoming Wind Sensitivity Study

To study the impact and identify internal transmission upgrades needed for the 1,500 MW Wyoming wind mapped to Eldorado 500 kV not assumed to be utilizing TransWest line, the ISO conducted a Wyoming wind sensitivity study. The additional Wyoming wind was found to exacerbate the overloads on Lugo – Victorville, Eldorado – Lugo, Eldorado – McCullough and Victorville – McCullough 500 kV lines, but it didn’t trigger any new overloads. Table F.10-20 shows a comparison of the loadings between the Wyoming wind sensitivity case and the baseline case.

Table F.10-20: EOP area 2040 on-peak deliverability constraints with and without additional Wyoming wind

Overloaded Facility	Contingency	w/ Addt'l WY wind (%)	2040 Baseline (%)
Sandy–Amargosa 138kV line	Trout Canyon – Sloan Canyon 500kV Nos.1&2 lines	212	212
Innovation–Northwest 138kV tie line		203	203
Gamebird 230/138kV transformer		175	176
Gamebird–Sandy 138kV line		140	140
Amargosa 230/138kV transformer		122	122
Innovation–Northwest 138kV tie line	Northwest – Desert View 230kV Nos.1&2 lines	138	137

	Innovation – Desert View 230kV Nos.1&2 lines	108	107
Lugo–Victorville 500kV line	Base Case	118	116
	Eldorado – Lugo 500kV line	136	133
	Lugo – Mohave 500kV line	127	124
	Eldorado – Mohave 500kV line	113	111
Eldorado–Lugo 500kV line	Base Case	100	98
	Lugo – Victorville 500kV line	120	116
	Lugo – Mohave 500kV line	104	102
Eldorado–McCullough 500kV line	Eldorado – Lugo 500kV line	155	141
	Lugo – Mohave 500kV line	137	123
Victorville-McCullough 500kV line	Base Case	104	102
	Eldorado – Lugo 500kV line	113	112
	Lugo – Mohave 500kV line	105	104
Sloan Cayon–Eldorado 500kV line	Base Case	107	109

Building onto the analysis presented in section F.10.2, two of the alternatives were further evaluated for the Wyoming wind sensitivity scenario. In the deliverability results table below, **Alternative 1** is a new Trout Canyon – Lugo 500 kV line; **Alternative 2** includes Marketplace – Adelanto AC-DC conversion project (1800 MW), Sagebrush interconnection project and a second Sloan Canyon – Eldorado 500 kV line. The amount of DC line capacity to be turned over the ISO was assumed to be 1800 MW.

Table F.10-21: Deliverability Results

Overloaded Facility	Contingency	w/ Addt'l WY wind (%)	Alt 1 (%)	Alt 2 (%)
Sandy–Amargosa 138kV line	Trout Canyon – Sloan Canyon 500kV Nos.1&2 lines	212	<90	150
Innovation–Northwest 138kV tie line		203	<90	111
Gamebird 230/138kV transformer		175	<90	134
Gamebird–Sandy 138kV line		140	<90	99
Amargosa 230/138kV transformer		122	<90	<90
Innovation–Northwest 138kV tie line		Northwest – Desert View 230kV Nos.1&2 lines	138	99
	Innovation – Desert View 230kV Nos.1&2 lines	108	<90	<90

Overloaded Facility	Contingency	w/ Addtl WY wind (%)	Alt 1 (%)	Alt 2 (%)
Lugo-Victorville 500kV line	Base Case	118	<90	<90
	Eldorado – Lugo 500kV line	136	99*	<90
	Lugo – Mohave 500kV line	127	92	<90
	Eldorado – Mohave 500kV line	113	<90	<90
Eldorado-Lugo 500kV line	Base Case	100	<90	<90
	Lugo – Victorville 500kV line	120	<90	<90
	Lugo – Mohave 500kV line	104	<90	<90
Eldorado-McCullough 500kV line	Eldorado – Lugo 500kV line	155	102	103
	Lugo – Mohave 500kV line	137	92	93
Victorville-McCullough 500kV line	Base Case	104	<90	96
	Eldorado – Lugo 500kV line	113	<90	106
	Lugo – Mohave 500kV line	105	<90	96
Sloan Cayon-Eldorado 500kV line	Base Case	107	<90	<90
Pahrump-Gamebird 138kV line	Gamebird-Wheeler Pass 230kV Nos.1&2 lines	<90	103	<90

\*The number is with existing Lugo – Victorville RAS

Alternative 1, Trout Canyon – Lugo 500 kV line, was found to be able to mitigate all but Eldorado – McCullough 500 kV line overload following Eldorado – Lugo 500 kV line outage. This could be mitigated by modifying the existing Lugo – Victorville RAS. It should also be noted that, with the existing Lugo – Victorville RAS tripping the maximum of 1,150 MW, the loading on Lugo – Victorville 500 kV line following loss of Eldorado – Lugo line is 99%.

Alternative 2 would have a better performance in mitigating Lugo – Victorville 500 kV line overloads. Same as Alternative 1, the Eldorado – McCullough 500 kV line would be slightly overloaded following loss of the Eldorado – Lugo 500 kV line, and the overload could be mitigated by modifying the existing Lugo – Victorville RAS. The Victorville – McCullough 500 kV line would still be overloaded following loss of the Eldorado – Lugo 500 kV line and RAS would not be sufficient or allowed. While Alternative 2 would greatly reduce loadings on the VEA 138 kV lines and transformers following the critical P7 contingency, it could not fully mitigate all the overloads. The Sloan Canyon RAS would still be needed and would need to curtail around 970 MW of resources.

### F.10.5. Conclusion and recommendation

The SCE and GLW/VEA East of Pisgah area deliverability assessment identified several on peak and off-peak deliverability constraints in 2035 and 2040 baseline portfolios and LLT sensitivity portfolios. The constraints could not be mitigated by existing or planned RAS, or by reducing generic battery storage or the Grid Enhancing Technology, and transmission solutions were needed.

MIC expansion request on the MEAD\_ITC intertie was behind the Eldorado – McCullough constraint in 2035 and 2040, and it was behind Sloan Canyon – Eldorado constraint in 2040. None of the 114 MW of MIC expansion request was deliverable in either year. MIC expansion requests on MEAD\_ITC and PALOVRDE\_ITC interties were behind the Lugo – Victorville constraint, and none of the 665.2 MW of MIC expansion request was deliverable in 2035 or 2040.

As communicated in the Final Decision for the 2025-2026 Transmission Planning Process, the CPUC asked the ISO to not trigger upgrades related to the additional 1,500 MW Wyoming wind mapped to Eldorado 500 kV and the 1,750 MW of New Mexico wind mapped to Lugo. Based on the analysis provided in section F.10.2, to mitigate all the constraints identified in EOP area under 2040 baseline portfolio without that 3,250 MW of Wyoming and New Mexico wind, two alternatives were proposed:

**Alternative 1:** New Trout Canyon – Lugo 500 kV line. This alternative was found to be able to mitigate all the constraints identified in East of Pisgah area with the 2040 baseline portfolio and eliminate the need for Sloan Canyon RAS, Desert View RAS and Lugo – Victorville N-1 RAS. However, with this alternative, there was a minor overload on Pahrump – Gamebird 138 kV line following loss of Gamebird – Wheeler Pass (Pahrump) 230 kV Nos. 1&2 lines that might require a RAS in the future.

**Alternative 2:** This alternative includes a combination of the Sagebrush interconnection project, Marketplace – Adelanto AC-DC conversion project and a second Sloan Canyon – Eldorado 500 kV line. Due to the uncertainty of the capacity increase to the existing Marketplace – Adelanto path that would be available to the ISO, a few scenarios were tested:

- Alternative 2A: 1,800 MW capacity increase available to the ISO
- Alternative 2B: 1,000 MW capacity increase available to the ISO
- Alternative 2C: only the AC component of the project.

Overall, this alternative fully mitigates the Lugo – Victorville 500 kV constraint in all scenarios. The main concern was the Victorville – McCullough 500 kV line overload. Under all scenarios tested, Victorville – McCullough 500 kV line overload could not be fully mitigated and a reduction in the ISO’s share of the DC transfer capability would increase the overload of the line. As a result, additional major transmission solutions would be needed with this alternative.

The Sloan Canyon RAS would still be required to mitigate multiple P7 contingency overloads on VEA 138 kV lines and transformer and would curtail around 970 MW resources. Future resource development within GLW-VEA area beyond the amount in 2040 baseline portfolio could be limited.

Table F.10-22: Alternative Analysis Summary Results

Overloaded Facility	Contingency	Base Portfolio Loading (%)	Alt 1 (%)	Alt 2A (%)	Alt 2B (%)	Alt 2C (%)
Sandy–Amargosa 138kV line	Trout Canyon – Sloan Canyon 500kV Nos. 1&2 lines	212	<90	149	149	149
Innovation–Northwest 138kV tie line		203	<90	111	111	111
Gamebird 230/138kV transformer		176	<90	134	134	134
Gamebird–Sandy 138kV line		140	<90	99	99	99
Amargosa 230/138kV transformer		122	<90	<90	<90	<90
Innovation–Northwest 138kV tie line	Northwest – Desert View 230kV Nos. 1&2 lines	137	<90	<90	<90	<90
	Innovation – Desert View 230kV Nos. 1&2 lines	107	<90	<90	<90	<90
Lugo–Victorville 500kV line	Base Case	116	<90	<90	<90	<90
	Eldorado – Lugo 500kV line	133	98	<90	<90	95
	Lugo – Mohave 500kV line	124	91	<90	<90	<90
	Eldorado – Mohave 500kV line	111	<90	<90	<90	<90
Eldorado–Lugo 500kV line	Lugo – Victorville 500kV line	116	<90	<90	<90	92
	Lugo – Mohave 500kV line	102	<90	<90	<90	95
Eldorado–McCullough 500kV line	Eldorado – Lugo 500kV line	141	<90	95	99	108
	Lugo – Mohave 500kV line	123	<90	<90	<90	96
Victorville–McCullough 500kV line	Base Case	102	<90	<90	102	109
	Eldorado – Lugo 500kV line	112	<90	103	112	116
	Lugo – Mohave 500kV line	104	<90	95	103	109
Sloan Cayon–Eldorado 500kV line	Base Case	109	<90	<90	<90	<90
Pahrump–Gamebird 138kV line	Gamebird–Wheeler Pass 230kV Nos. 1&2 lines	<90	103	<90	<90	<90

A second Lugo 500 kV switchyard was identified as necessary to accommodate the additional generation tie-line interconnection points needed for generation interconnection requests in Cluster 15, and to address the short circuit duty increase caused by the generation interconnection requests. The generation in the IRP resource portfolios provided for study in the 2025-2026 TPP drive the Lugo 500 kV bus short circuit duty to 95.6% in 2030 and 96.9% in 2040 on the 63 kA circuit breakers. The Cluster 15 studies identified the need to connect the existing Lugo 500 kV switchyard to the new Lugo 500 kV switchyard via a short transmission line with a 40 Ohm series reactor. The cost for this mitigation was estimated to be approximately \$350 to \$500 million in 2035 dollars. With the addition of a new Trout Canyon-Lugo 500 kV line or for the Marketplace-Adelanto alternative, the need for this mitigation would be expected to be needed for both generation interconnection projects or for the transmission upgrade project. Therefore, the ISO is including the cost of this mitigation with both Alternative 1 and Alternative 2.

The cost estimate of the two alternatives are summarized in the table below. The cost estimate for the Trout Canyon-Lugo 500 kV line is based on \$5 M to \$7M cost per mile for the approximately 180 mile line. The per mile costs are based on the per mile cost for several 500 kV line projects that were selected in the competitive transmission project solicitation process. The interconnection cost at Trout Canyon is estimated to be between \$20 M and \$40 M based on similar interconnection costs. The cost estimate for the Marketplace Adelanto HVDC conversion project and the Sagebrush Interconnection Project are based on the request window submittals of for these projects. All costs are escalated to 2035.

Table F.10-23: Alternative Cost Summary

A se	Upgrade	Cost (\$M)
Alt 1	New Trout Canyon - Lugo 500 kV transmission line and interconnection at Trout Canyon	\$920 to \$1,300
	New Lugo 500 kV switchyard, line interconnection cost, and 40 Ohm series reactor	\$350 to \$500
	<b>Total</b>	<b>\$1,270 to \$1,800</b>
Alt 2	Marketplace – Adelanto HVDC conversion	\$1,340 to \$1634
	Sagebrush Interconnection Project	\$208
	New Sloan Canyon - Eldorado 500 kV transmission line	\$50 to \$100
	New Lugo 500 kV switchyard and 40 Ohm series reactor	\$330 to \$460
	<b>Total</b>	<b>\$1,928 to \$2,402</b>

Based on the above analysis, both Alternative 1 and Alternative 2 could mitigate Lugo – Victorville, Eldorado – Lugo, Eldorado – McCullough and Sloan Canyon – Eldorado 500 kV lines overloads identified in 2040 baseline portfolio deliverability study. Alternative 1 could also mitigate all the overloads on the Victorville – McCullough 500 kV line. But with Alternative 2, Victorville – McCullough 500 kV line overloads could not be mitigated and would require major additional transmission solutions. Furthermore, Alternative 1 could mitigate all the Category P7 contingencies overloads on VEA 138 kV lines and transformers and eliminate Sloan Canyon RAS and Desert View RAS. While Alternative 2 could not mitigate all the overloads and would require the Sloan Canyon RAS.

Based on the evaluation above, **Alternative 1**, a new Trout Canyon – Lugo 500 kV line, is recommended for approval.

## F.11. SCE Northern Area

The total capacity of resources, by resource type, selected with Full Capacity Deliverability Status (FCDS) as well as those selected as Energy Only (EO) in the SCE Northern interconnection area are listed in Table F.11-1. The portfolios in the interconnection area are comprised of solar, wind (in-state), battery storage, long duration energy storage, and distributed solar resources. All portfolio resources are modeled in policy-driven assessments except in the on-peak deliverability assessment in which only FCDS resources are modeled.

*Table F.11-1: SCE Northern Interconnection Area – Base and Sensitivity Portfolios by Resource Types (FCDS, EO and Total)*

Resource Type	2035 Base Portfolio			2040 Base Portfolio			2035 Sensitivity Portfolio		
	FCDS (MW)	EO (MW)	Total (MW)	FCDS (MW)	EO (MW)	Total (MW)	FCDS (MW)	EO (MW)	Total (MW)
Solar	1,178	1,608	<b>2,786</b>	1,678	3,718	<b>5,396</b>	1,052	1,508	<b>2,560</b>
Wind – In State	674	0	<b>674</b>	674	0	<b>674</b>	674	0	<b>674</b>
Wind – Out-of-State	0	0	<b>0</b>	0	0	<b>0</b>	0	0	<b>0</b>
Wind - Offshore	0	0	<b>0</b>	0	0	<b>0</b>	0	0	<b>0</b>
Li Battery – 4 hr.	3,224	0	<b>3,224</b>	3,224	0	<b>3,224</b>	3,224	0	<b>3,224</b>
Li Battery – 8 hr.	509	0	<b>509</b>	1,584	0	<b>1,584</b>	454	0	<b>454</b>
Long Duration Energy Storage (LDES)	400	0	<b>400</b>	400	0	<b>400</b>	900	0	<b>900</b>
Geothermal	0	0	<b>0</b>	0	0	<b>0</b>	0	0	<b>0</b>
Biomass/Biogas	0	0	<b>0</b>	0	0	<b>0</b>	0	0	<b>0</b>
Distributed Solar	0	24	<b>24</b>	0	24	<b>24</b>	0	24	<b>24</b>
<b>Total</b>	<b>5,985</b>	<b>1,632</b>	<b>7,617</b>	<b>7,560</b>	<b>3,742</b>	<b>11,302</b>	<b>6,304</b>	<b>1,532</b>	<b>7,836</b>

Table F.11-2 shows adjustments to the portfolios in the SCE Northern Interconnection Area made with CPUC staff guidance to account for additional in-development resources modeled by the PTO based on the project status.

Table F.11-2: SCE Northern Interconnection Area – Modifications to the portfolios to account for adjustments to in-development resources

Substation	Voltage	Resource Type	2035 Base Portfolio			2040 Base Portfolio			2035 Sensitivity Portfolio		
			FCDS (MW)	EO (MW)	Total (MW)	FCDS (MW)	EO (MW)	Total (MW)	FCDS (MW)	EO (MW)	Total (MW)
Antelope	230 kV	Li Battery – 4 hr.	25	0	25	25	0	25	25	0	25
Antelope	230 kV	Li Battery – 8 hr.	0	0	0	-13	0	-13	0	0	0
Moorpark	230 kV	Li Battery – 4 hr.	150	0	150	150	0	150	150	0	150
Moorpark	230 kV	Li Battery – 8 hr.	0	0	0	-75	0	-75	0	0	0
Pastoria	230 kV	Solar	39	-39	0	39	-39	0	39	-39	0
Rector	66 kV	Li Battery – 4 hr.	80	0	80	80	0	80	80	0	80
Rector	66 kV	Li Battery – 8 hr.	0	0	0	-40	0	-40	0	0	0
Springville	66 kV	Li Battery – 4 hr.	40	0	40	40	0	40	40	0	40
Springville	66 kV	Li Battery – 8 hr.	0	0	0	-20	0	-20	0	0	0
Springville	66 kV	Solar	0	40	40	0	0	0	0	40	40
Vestal	230 kV	Li Battery – 8 hr.	-40	0	-40	0	0	0	0	0	0
Whirlwind	230 kV	Solar	40	-40	0	0	0	0	40	-40	0
Whirlwind	230 kV	Li Battery – 4 hr.	40	0	40	40	0	40	40	0	40
Whirlwind	230 kV	Li Battery – 8 hr.	0	0	0	-20	0	-20	0	0	0
Whirlwind	230 kV	Long Duration Energy Storage (LDES)	100	0	100	100	0	100	0	0	0
Windhub	230 kV	Solar	0	150	150	0	0	0	0	150	150
Windhub	500 kV	Li Battery – 4 hr.	635	0	635	635	0	635	635	0	635
Windhub	500 kV	Li Battery – 8 hr.	0	0	0	-80	0	-80	0	0	0
Windhub	500 kV	Solar	0	0	0	0	0	0	97	0	97
<b>Total</b>			<b>1,109</b>	<b>111</b>	<b>1,220</b>	<b>862</b>	<b>-39</b>	<b>823</b>	<b>1,146</b>	<b>111</b>	<b>1,257</b>

Table F.11-3 shows the portfolios modeled in the deliverability assessment of the SCE Northern Interconnection Area after making the adjustments specified in Table F.11-2.

Table F.11-3: SCE Northern Interconnection Area – Base and Sensitivity Portfolios by Resource Types including adjustments<sup>6</sup> (FCDS, EO and Total)

Resource Type	2035 Base Portfolio			2040 Base Portfolio			2035 Sensitivity Portfolio		
	FCDS (MW)	EO (MW)	Total (MW)	FCDS (MW)	EO (MW)	Total (MW)	FCDS (MW)	EO (MW)	Total (MW)
Solar	1,257	1,719	2,976	1,717	3,679	5,396	1,228	1,619	2,847
Wind – In State	674	0	674	674	0	674	674	0	674
Wind – Out-of-State	0	0	0	0	0	0	0	0	0
Wind - Offshore	0	0	0	0	0	0	0	0	0
Li Battery – 4 hr.	4,194	0	4,194	4,194	0	4,194	4,194	0	4,194
Li Battery – 8 hr.	469	0	469	1,337	0	1,337	454	0	454
Long Duration Energy Storage (LDES)	500	0	500	500	0	500	900	0	900
Geothermal	0	0	0	0	0	0	0	0	0
Biomass/Biogas	0	0	0	0	0	0	0	0	0
Distributed Solar	0	24	24	0	24	24	0	24	24
<b>Total</b>	<b>7,094</b>	<b>1,743</b>	<b>8,837</b>	<b>8,422</b>	<b>3,703</b>	<b>12,125</b>	<b>7,450</b>	<b>1,643</b>	<b>9,093</b>

The 2035 Base Portfolio resources, as identified in the CPUC busbar mapping for the SCE Northern interconnection area, are illustrated on the single-line diagram in Figure F.11-1.

Figure F.11-1: SCE Northern Interconnection Area – Mapped<sup>6</sup> 2035 Base Portfolio

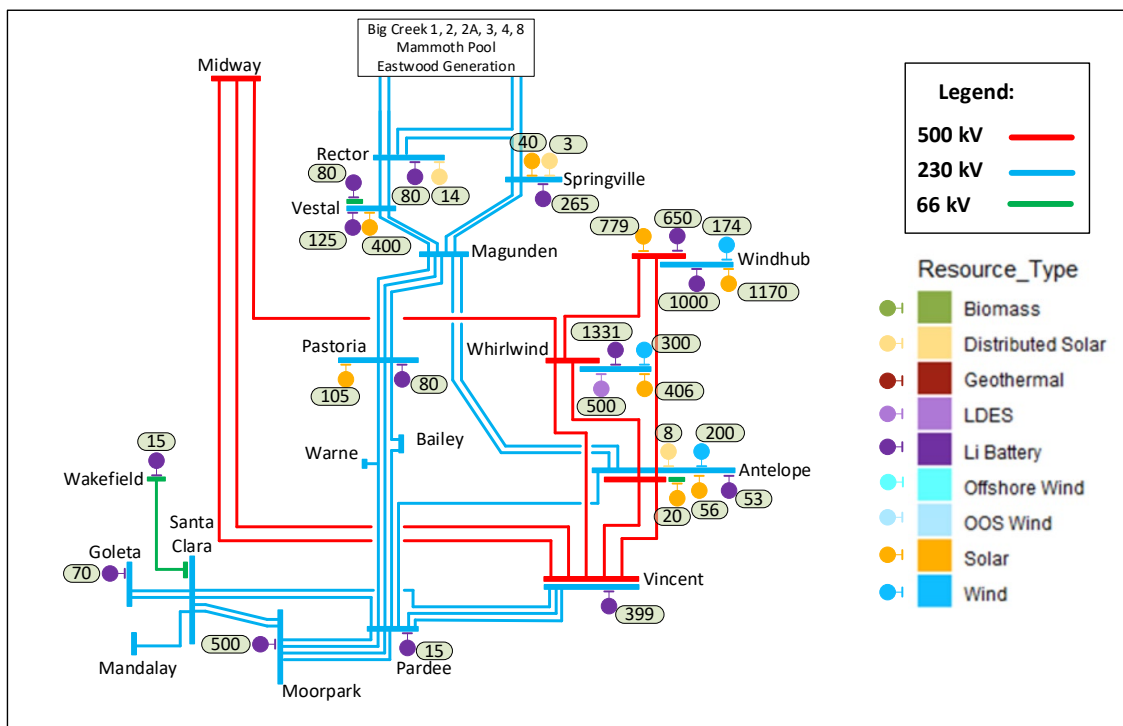

<sup>6</sup> Mapped base portfolio includes the adjustments to the base portfolio made by CPUC staff in the SCE Northern Interconnection Area to account for additional in-development resources identified.

The 2040 Base Portfolio resources, as identified in the CPUC busbar mapping for the SCE Northern interconnection area, are illustrated on the single-line diagram in Figure F.11-2.

Figure F.11-2: SCE Northern Interconnection Area – Mapped<sup>7</sup> 2040 Base Portfolio

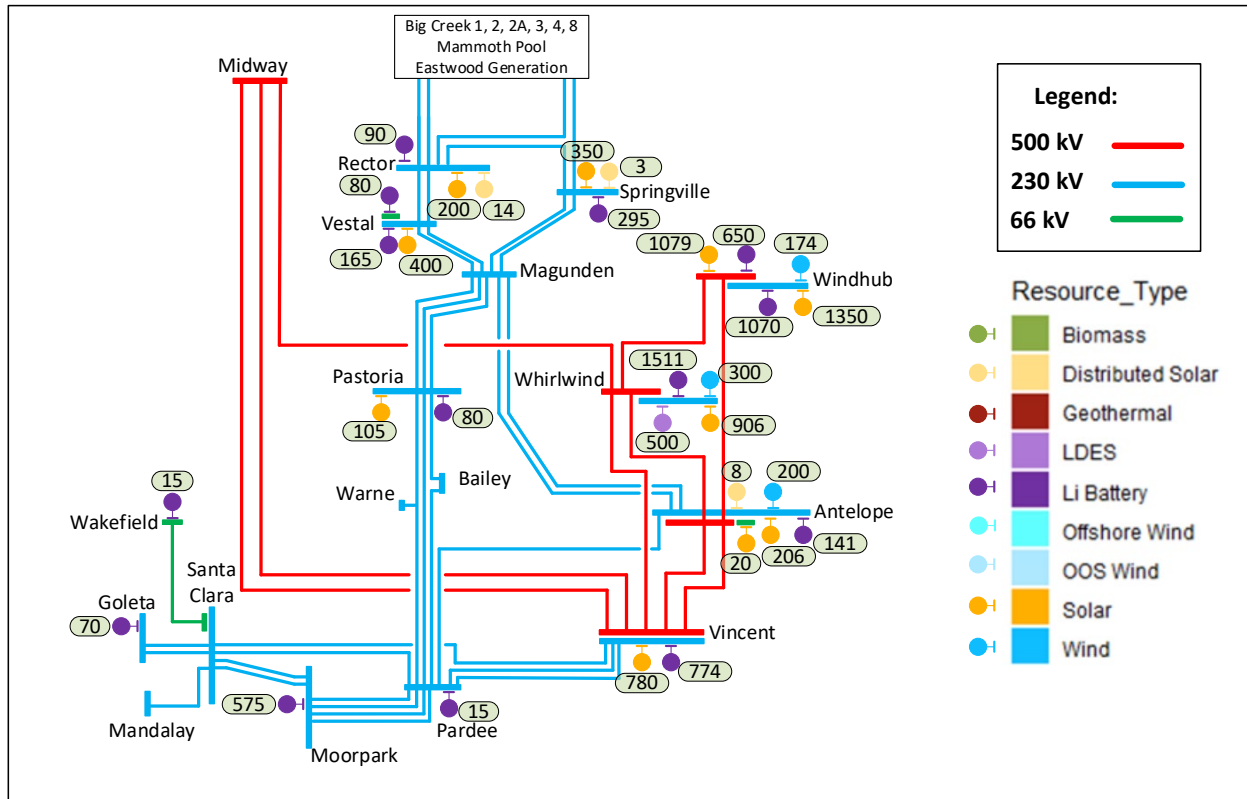

<sup>7</sup> Mapped base portfolio includes the adjustments to the base portfolio made by CPUC staff in the SCE Northern Interconnection Area to account for additional in-development resources identified.

The 2035 Sensitivity Portfolio resources, as identified in the CPUC busbar mapping for the SCE Northern interconnection area, are illustrated on the single-line diagram in Figure F.11-3.

Figure F.11-3: SCE Northern Interconnection Area – Mapped<sup>8</sup> 2035 Sensitivity Portfolio

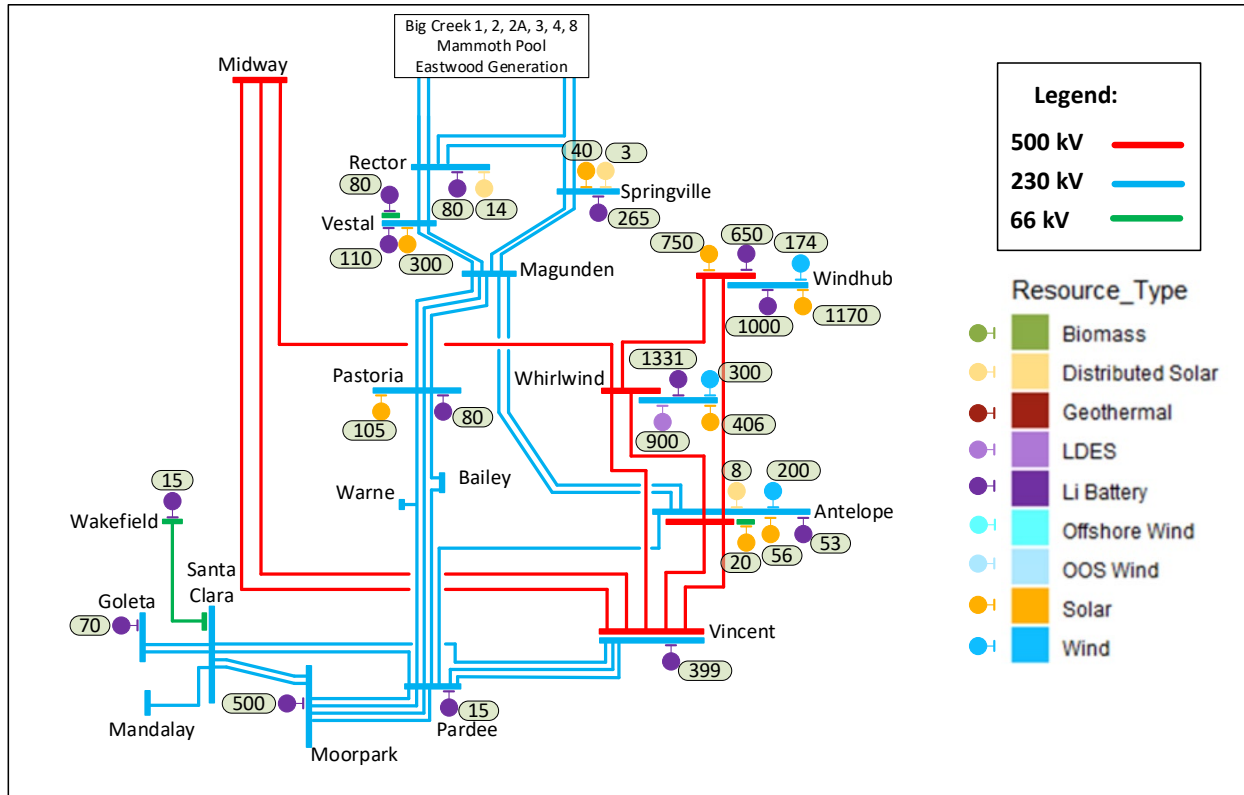

### F.11.1. 2035 On-peak results

#### Windhub 500/230 kV Transformer Constraint

The deliverability of FC resources interconnecting at Windhub 230 kV buses is limited by thermal overloading of the 500/230 kV transformers under Category P1 conditions as shown in Table F.11-4. The constraint is identified in both base and sensitivity portfolios under the HSN condition, where 509 MW of capacity resources interconnected at Bus A will be undeliverable without mitigation as shown in Table F.11-5. The constraint can be mitigated by the existing Windhub AA Bank CRAS.

<sup>8</sup> Mapped LLT portfolio includes the adjustments to the LLT portfolio made by CPUC staff in the SCE Northern Interconnection Area to account for additional in-development resources identified.

Table F.11-4: Windhub 500/230 kV transformer deliverability constraint

Overloaded Facility	Contingency	Loading (%)	
		Base	Sensitivity
Windhub #1 or #2 500/230 kV transformer <sup>9</sup>	Windhub #1 or #2 500/230 kV transformer	130	130

Table F.11-5: Windhub #1 and #2 500/230 kV transformer constraint summary

Affected transmission zones		Tehachapi area – Windhub 230 kV Bus A	
		Base	Sensitivity
Portfolio resources behind the constraint (Installed FCDS capacity)		1,193 MW	
Generic portfolio battery storage behind the constraint (Installed FCDS capacity)		0 MW	
Deliverable portfolio resources w/o mitigation (Installed FCDS capacity)		684 MW	
Total undeliverable baseline and portfolio resources (Installed FCDS capacity)		509 MW	
Mitigation Options	RAS	Existing Windhub AA Bank CRAS	
	Reduce generic battery storage (MW)	Not applicable	
	Grid Enhancing Technology	Not needed	
	Transmission upgrade including cost	Not needed	
Recommended Mitigation		Existing Windhub AA Bank CRAS	

Table F.11-6: Windhub #1 and #2 500/230 kV transformer constraint affected inerties

Affected inerties	N/A	
	Base	Sensitivity
MIC expansion request MW behind constraint	N/A	N/A
Deliverable MIC expansion request MW	N/A	N/A

<sup>9</sup> The loading on the transformers depends on which Windhub 230 kV bus, Bus A or Bus B, generic portfolio resources are mapped to, could overload Banks #3 and #4 500/230 kV transformers.

## Windhub Area Export Constraint

The deliverability of FC resources interconnecting at Windhub Substation is limited by the simultaneous or overlapping outage of Antelope – Windhub 500 kV Line and Whirlwind – Windhub 500 kV Line without time for system adjustments, which results in islanding of the Windhub System and the consequential loss of 3000 to 6000 MW of generation.

The loss of one Windhub 500 kV line results in exposing the entire ISO and surrounding areas to voltage collapse-driven cascading outages for loss of the second Windhub 500 kV line starting in Cluster 13. This results in the need to immediately curtail up to 5000 MW of generation, or cascading outages if the second contingency occurs before the generation can be curtailed. Therefore, an area deliverability constraint has been enforced to address this voltage collapse and loss of resource issue.

The constraint is identified in both base and sensitivity portfolios under the HSN condition, where 811 MW and 787 MW of capacity resources, respectively, interconnected at Windhub substation, will be undeliverable without mitigation as shown in Table F.11-8.

The ISO assessed the following transmission alternatives:

1. Windhub – PG&E Substation 500 kV line

This alternative involves constructing a new 500 kV line from Windhub to a PG&E substation that has yet to be determined. The selection of the substation will depend on whether upgrades to both Path 26 and Path 15 are required.

The ISO, in collaboration with PG&E and SCE, will continue to evaluate the feasibility and cost of this option.

2. Windhub – Whirlwind 500 kV line

This alternative involves constructing a second 16-mile 500 kV line from Windhub to Whirlwind.

The ISO, in collaboration with SCE, will continue to evaluate the feasibility and cost of this option.

3. Windhub – Vincent 230 kV double circuit

This alternative was submitted through the Request Window and involves building a 47-mile, 230 kV double circuit line using high-capacity double-bundle conductors from Windhub to Vincent. The alternative would have an estimated cost of \$300 to \$400 million.

The ISO, in collaboration with SCE, will continue to evaluate the feasibility of this option.

The CPUC did not intend to trigger an upgrade for this constraint in the 2025-2026 TPP portfolios. The main driver for exceeding the constraint is the additional in-development resources modeled by the PTO. Therefore, the ISO and the CPUC had discussions to remove the 203 MW of generic resources at Windhub substation in the portfolios to avoid the need for a transmission upgrade in this planning cycle.

Table F.11-7: Windhub Area Export deliverability constraint

Overloaded Facility	Contingency	Loading (%)	
		Base	Sensitivity
Windhub Constraint	Antelope – Windhub and Whirlwind – Windhub 500 kV lines	122	122

Table F.11-8: Windhub Area Export constraint summary

Affected transmission zones		Tehachapi area – Windhub	
		Base	Sensitivity
Portfolio resources behind the constraint (Installed FCDS capacity)		2,662 MW	2,634 MW
Generic portfolio battery storage behind the constraint (Installed FCDS capacity)		0 MW	
Deliverable portfolio resources w/o mitigation (Installed FCDS capacity)		1,851 MW	1,847 MW
Total undeliverable baseline and portfolio resources (Installed FCDS capacity)		811 MW	787 MW
Mitigation Options	RAS	Not applicable	
	Reduce generic battery storage (MW)	Not applicable	
	Grid Enhancing Technology	Not applicable	
	Transmission upgrade including cost	1. Windhub – PG&E Substation 500 kV line 2. Windhub – Whirlwind 500 kV line 3. Windhub – Vincent 230 kV double circuit (\$300M-\$400M)	
Recommended Mitigation		Not needed	

Table F.11-9: Windhub Area Export constraint affected interties

Affected interties	N/A	
	Base	Sensitivity
MIC expansion request MW behind constraint	N/A	N/A
Deliverable MIC expansion request MW	N/A	N/A

### North of Magunden Constraint

The deliverability of FC resources interconnecting in the North of Magunden area is limited by thermal overloading of the Big Creek 3 – Rector 230 kV No. 2 line under Category P7 conditions as shown in Table F.11-10. The constraint is identified in both base and sensitivity portfolios under the HSN condition, where 406 MW of capacity resources will be undeliverable without mitigation as shown in Table F.11-11. The constraint can be mitigated by the existing Big Creek-San Joaquin Valley RAS.

Table F.11-10: North of Magunden deliverability constraint

Overloaded Facility	Contingency	Loading (%)	
		Base	Sensitivity
Big Creek 3 – Rector 230 kV No. 2	Big Creek 1 – Rector 230 kV No. 1 and Big Creek 3 – Rector 230 kV No. 1	120	120
Big Creek 4 – Springville 230 kV No. 1	Big Creek 1 – Rector 230 kV No. 1 and Big Creek 3 – Rector 230 kV No. 1	100	100

Table F.11-11: North of Magunden constraint summary

Affected transmission zones		North of Magunden	
		Base	Sensitivity
Portfolio resources behind the constraint (Installed FCDS capacity)		272 MW	
Generic portfolio battery storage behind the constraint (Installed FCDS capacity)		0 MW	
Deliverable portfolio resources w/o mitigation (Installed FCDS capacity)		0 MW	
Total undeliverable baseline and portfolio resources (Installed FCDS capacity)		406 MW	
Mitigation Options	RAS	Existing Big Creek-San Joaquin Valley RAS	
	Reduce generic battery storage (MW)	Not applicable	

	Grid Enhancing Technology	Not needed
	Transmission upgrade including cost	Not needed
Recommended Mitigation		Existing Big Creek-San Joaquin Valley RAS

Table F.11-12: North of Magunden constraint affected inerties

Affected inerties	N/A	
	Base	Sensitivity
MIC expansion request MW behind constraint	N/A	N/A
Deliverable MIC expansion request MW	N/A	N/A

### Whirlwind 500/230 kV Transformer Constraint

The deliverability of FC resources interconnecting at Whirlwind 230 kV buses is limited by thermal overloading of the 500/230 kV transformers under Category P1 conditions as shown in Table F.11-13. The constraint is identified in both base and sensitivity portfolios under the HSN condition, where 142 MW and 531 MW of capacity resources, respectively, will be undeliverable without mitigation as shown in Table F.11-14. The constraint can be mitigated by the existing Whirlwind AA Bank CRAS.

Table F.11-13: Whirlwind 500/230 kV transformer deliverability constraint

Overloaded Facility	Contingency	Loading (%)	
		Base	Sensitivity
Whirlwind #1, #3 or #4 500/230 kV transformer	Whirlwind #1, #3 or #4 500/230 kV transformer	102	116

Table F.11-14: Whirlwind 500/230 kV transformer constraint summary

Affected transmission zones	Tehachapi area – Whirlwind 230 kV	
	Base	Sensitivity
Portfolio resources behind the constraint (Installed FCDS capacity)	2,202 MW	2,602 MW
Generic portfolio battery storage behind the constraint (Installed FCDS capacity)	0 MW	
Deliverable portfolio resources w/o mitigation (Installed FCDS capacity)	2,060 MW	2,071 MW
Total undeliverable baseline and portfolio resources (Installed FCDS capacity)	142 MW	531 MW

Mitigation Options	RAS	Existing Whirlwind AA Bank CRAS
	Reduce generic battery storage (MW)	Not applicable
	Grid Enhancing Technology	Not needed
	Transmission upgrade including cost	Not needed
Recommended Mitigation		Existing Whirlwind AA Bank CRAS

Table F.11-15: Whirlwind 500/230 kV transformer constraint affected inerties

Affected inerties	N/A	
	Base	Sensitivity
MIC expansion request MW behind constraint	N/A	N/A
Deliverable MIC expansion request MW	N/A	N/A

### Midway–Whirlwind 500 kV Line Constraint

The deliverability of FC resources interconnecting in the Tehachapi and North of Magunden areas is limited by thermal overloading of PG&E’s portion of Midway–Whirlwind 500 kV line under Category P0 condition as shown in Table F.11-16. The constraint is identified in both base and sensitivity portfolios under the HSN condition, where 1,268 MW and 1,416 MW of capacity resources, respectively, will be undeliverable without mitigation as shown in Table F.11-17. Since the constraint occurs under normal system conditions, RAS is not a viable mitigation and there is only 15 MW of generic portfolio battery storage in the base portfolio, therefore relocating it to other substations outside the affected transmission zones has a marginal reduction in the overload.

The Midway – Whirlwind 500 kV line (PG&E segment) has a normal rating of 1,503 MVA and experiences overloads under conditions of high Tehachapi and North of Magunden generation output, even when Path 26 south-to-north (S>N) flows are below 3,000 MW. In the 2035 base and sensitivity portfolios, the pre-shift Path 26 S>N flows were 2,205 MW and 2,138 MW, respectively, while the Midway–Whirlwind 500 kV line carried flows of 1,502 MW and 1,546 MW, respectively. These results indicate that approximately 70% of the Path 26 flow S>N is carried on the Midway–Whirlwind 500 kV transmission line.

The ISO assessed the following transmission alternatives:

1. Bypass the series capacitor of the Midway–Whirlwind 500 kV line

Bypassing the series capacitor of the Midway–Whirlwind 500 kV line is sufficient to address the on-peak deliverability constraint for both the base case condition without contingency and with the outage of both Vincent – Midway 500 kV lines, assuming a Path 26 S>N flow of 3,000 MW.

The ISO conducted a reliability study to evaluate whether the series capacitor could be bypassed permanently, seasonally, or whether constant switching would be required as system conditions change. The assessment concluded that the series capacitor cannot be bypassed permanently, since reliability concerns were identified even when Path 26 north-to-south (N>S) flows are below 3,000 MW. Specifically, under the Category P1 contingency of Midway – Vincent No. 1 or No. 2 500 kV line, the remaining parallel 500 kV line becomes overloaded. The emergency rating of these transmission lines is limited by the 4-hr rating of the series capacitors to 2078 MVA.

2. Uprate Midway – Whirlwind 500 kV line (PGE segment normal rating)

This alternative involves increasing the normal rating of PG&E’s portion of the Midway – Whirlwind 500 kV line, which is currently limited to 1503 MVA to achieve a higher summer emergency rating of 3265 MVA. This change would only address the Category P0 overload identified in the on-peak assessment. However, increasing the normal rating could result in a reduction of the 30-minute rating which could impact the reliability of the system with heavy Path 26 N>S flows. The ISO, in collaboration with PG&E and SCE, will continue to evaluate the feasibility of this option.

3. Reconductor PG&E segment of Midway – Whirlwind with advanced conductor

This alternative involves reconductoring with advanced conductors PG&E’s portion of the Midway – Whirlwind 500 kV line, which potentially could avoid the need to replace transmission towers. By reconductoring this segment the normal rating of the line will increase to 2078 MVA, as the next limiting factors are the series capacitor and SCE’s conductor line-to-ground sag.

The ISO, in collaboration with PG&E and SCE, will continue to evaluate the feasibility and cost of this option.

#### 4. Windhub – PG&E Substation 500 kV line

This alternative involves constructing a new 500 kV line from Windhub to a PG&E substation that has yet to be determined. The selection of the substation will depend on whether upgrades to both Path 26 and Path 15 are required.

The ISO, in collaboration with PG&E and SCE, will continue to evaluate the feasibility and cost of this option.

#### 5. Pacific Transmission Expansion Project (PTEP)

To mitigate the thermal overload of Midway – Whirlwind 500 kV line in heavy Path 26 S>N flow conditions, the PTEP HVDC would need to transfer real power from SCE to PG&E. The main disadvantage of this alternative is that it could create a loop flow through Path 26 500 kV lines by having a S>N flow from Whirlwind to Midway and a N>S flow from Midway to Vincent if the transfer through PTEP HVDC is not adjusted correctly.

The alternative would have an estimated cost of \$2.42 billion. The economic benefits of the PTEP was evaluated using production cost simulation. The results, which are presented in Appendix G, did not find the line to be economic at this time with the current TEAM methodology.

#### 6. Kern-Southland Energy Link (K-SEL)

To mitigate the thermal overload of Midway – Whirlwind 500 kV line in heavy Path 26 S>N flow conditions, the K-SEL HVDC would need to transfer real power from SCE to PG&E. Similar to the PTEP, the K-SEL could create a loop flow through Path 26 500 kV lines by having a S>N flow from Whirlwind to Midway and a N>S flow from Midway to Vincent if the transfer through K-SEL HVDC is not adjusted correctly.

The alternative would have an estimated cost of \$2 to \$4 billion. The economic benefits of the K-SEL was evaluated using production cost simulation. The results, which are presented in Appendix G, did not find the line to be economic at this time.

Since upgrading Path 26 in the south-to-north direction will lead to increased flows and cause additional stress on Path 15, a more comprehensive analysis of this concern is needed, and will be performed in the next planning cycle. In the interim, the ISO recommends congestion management as a mitigation solution for this planning cycle. Based on the expected 2026-2027 TPP portfolios, there will be an increased need for a transmission capacity expansion for Path 26 and potentially Path 15. Therefore, the ISO will continue a detailed evaluation of all potential alternatives in next year's TPP.

Table F.11-16: Midway–Whirlwind 500 kV line deliverability constraint

Overloaded Facility	Contingency	Loading (%)	
		Base	Sensitivity
Midway – Whirlwind 500 kV No. 3 (PG&E Segment)	Base Case	113	117

Table F.11-17: Midway–Whirlwind 500 kV line constraint summary

Affected transmission zones		Tehachapi and North of Magunden areas	
		Base	Sensitivity
Portfolio resources behind the constraint (Installed FCDS capacity)		6,244 MW	6,599 MW
Generic portfolio battery storage behind the constraint (Installed FCDS capacity)		15 MW	0 MW
Deliverable portfolio resources w/o mitigation (Installed FCDS capacity)		4,976 MW	5,183 MW
Total undeliverable baseline and portfolio resources (Installed FCDS capacity)		1,268 MW	1,416 MW
Mitigation Options	RAS	Not applicable	
	Reduce generic battery storage (MW)	Not sufficient	
	Grid Enhancing Technology	Reconductor PG&E segment of Midway – Whirlwind with advanced conductor	
	Transmission upgrade including cost	1. Bypass the series capacitor of the Midway – Whirlwind 500 kV line (No cost) 2. Uprate Midway – Whirlwind 500 kV line (PGE segment normal rating) (No cost) 3. Reconductor PG&E segment of Midway – Whirlwind with advanced conductor 4. Windhub – PG&E Substation 500 kV line 5. PTEP (\$2.42B) 6. K-SEL (\$2-4B)	
Recommended Mitigation		Congestion Management	

Table F.11-18: Midway–Whirlwind 500 kV line constraint affected inertias

Affected inertias	N/A	
	Base	Sensitivity
MIC expansion request MW behind constraint	N/A	N/A
Deliverable MIC expansion request MW	N/A	N/A

### F.11.2. 2040 On-peak results

#### Windhub 500/230 kV Transformer Constraint

The deliverability of FC resources interconnecting at Windhub 230 kV buses is limited by thermal overloading of the 500/230 kV transformers under Category P1 conditions as shown in Table F.11-19. The constraint is identified in the base portfolio under the HSN condition, where 680 MW of capacity resources interconnected at Bus A will be undeliverable without mitigation as shown in Table F.11-20. The constraint can be mitigated by the existing Windhub AA Bank CRAS.

*Table F.11-19: Windhub 500/230 kV transformer deliverability constraint*

Overloaded Facility	Contingency	Base Portfolio Overloading (%)	
		HSN	SSN
Windhub #1 or #2 500/230 kV transformer <sup>10</sup>	Windhub #1 or #2 500/230 kV transformer	133	<100

*Table F.11-20: Windhub #1 and #2 500/230 kV transformer constraint summary*

Affected transmission zones		Tehachapi area – Windhub 230 kV Bus A	
		HSN	SSN
Portfolio resources behind the constraint (Installed FCDS capacity)		1,393 MW	
Generic portfolio battery storage behind the constraint (Installed FCDS capacity)		70 MW	
Deliverable portfolio resources w/o mitigation (Installed FCDS capacity)		713 MW	1,393 MW
Total undeliverable baseline and portfolio resources (Installed FCDS capacity)		680 MW	0 MW
Mitigation Options	RAS	Existing Windhub AA Bank CRAS	Not needed
	Reduce generic battery storage (MW)	Not needed	
	Grid Enhancing Technology	Not needed	
	Transmission upgrade including cost	Not needed	
Recommended Mitigation		Existing Windhub AA Bank CRAS	

<sup>10</sup> The loading on the transformers depends on which Windhub 230 kV bus, Bus A or Bus B, generic portfolio resources are mapped to, could overload Banks #3 and #4 500/230 kV transformers.

Table F.11-21: Windhub #1 and #2 500/230 kV transformer constraint affected inerties

Affected inerties	N/A	
	HSN	SSN
MIC expansion request MW behind constraint	N/A	N/A
Deliverable MIC expansion request MW	N/A	N/A

### Windhub Area Export Constraint

The deliverability of FC resources interconnecting at Windhub Substation is limited by the simultaneous or overlapping outage of Antelope – Windhub 500 kV Line and Whirlwind – Windhub 500 kV Line without time for system adjustments, as explained in section F.11.1. The constraint is identified in the base portfolio under the HSN condition, where 1,103 MW of capacity resources interconnected at Windhub substation will be undeliverable without mitigation as shown in Table F.11-23.

The transmission mitigation options studied for the 2040 on-peak deliverability constraint are described in section F.11.1 for the Windhub Area Export 2035 on-peak deliverability constraint. The CPUC did not intend to trigger an upgrade for this constraint in the portfolio. The main driver for exceeding the constraint is the additional in-development resources modeled by the PTO. Therefore, the ISO and the CPUC had discussions to remove the 502 MW of generic resources at Windhub substation in the portfolios to avoid the need for a transmission upgrade in this planning cycle.

Table F.11-22: Windhub Area Export deliverability constraint

Overloaded Facility	Contingency	Base Portfolio Overloading (%)	
		HSN	SSN
Windhub Constraint	Antelope – Windhub and Whirlwind – Windhub 500 kV lines	124	<100

Table F.11-23: Windhub Area Export constraint summary

Affected transmission zones		Tehachapi area – Windhub	
		HSN	SSN
Portfolio resources behind the constraint (Installed FCDS capacity)		2,961 MW	
Generic portfolio battery storage behind the constraint (Installed FCDS capacity)		70 MW	
Deliverable portfolio resources w/o mitigation (Installed FCDS capacity)		1,858 MW	2,961 MW
Total undeliverable baseline and portfolio resources (Installed FCDS capacity)		1,103 MW	0 MW
Mitigation Options	RAS	Not applicable	
	Reduce generic battery storage (MW)	Not sufficient	
	Grid Enhancing Technology	Not applicable	
	Transmission upgrade including cost	1. Windhub – PG&E Substation 500 kV line 2. Windhub – Whirlwind 500 kV line 3. Windhub – Vincent 230 kV double circuit (\$300M-\$400M)	
Recommended Mitigation		Not needed	

Table F.11-24: Windhub Area Export constraint affected inerties

Affected inerties	N/A	
	HSN	SSN
MIC expansion request MW behind constraint	N/A	N/A
Deliverable MIC expansion request MW	N/A	N/A

### North of Magunden Constraint

The deliverability of FC resources interconnecting in the North of Magunden area is limited by thermal overloading of the Big Creek 3 – Rector 230 kV No. 2 line under Category P7 conditions as shown in Table F.11-25. The constraint is identified in the base portfolio under both HSN and SSN conditions, where 589 MW of capacity resources will be undeliverable without mitigation as shown in Table F.11-26. The constraint can be mitigated by the existing Big Creek-San Joaquin Valley RAS.

Table F.11-25: North of Magunden deliverability constraint

Overloaded Facility	Contingency	Base Portfolio Overloading (%)	
		HSN	SSN
Big Creek 3 – Rector 230 kV No. 2	Big Creek 1 – Rector 230 kV No. 1 and Big Creek 3 – Rector 230 kV No. 1	116	116

Table F.11-26: North of Magunden constraint summary

Affected transmission zones		North of Magunden	
		HSN	SSN
Portfolio resources behind the constraint (Installed FCDS capacity)		473 MW	
Generic portfolio battery storage behind the constraint (Installed FCDS capacity)		30 MW	
Deliverable portfolio resources w/o mitigation (Installed FCDS capacity)		0 MW	
Total undeliverable baseline and portfolio resources (Installed FCDS capacity)		589 MW	
Mitigation Options	RAS	Existing Big Creek-San Joaquin Valley RAS	
	Reduce generic battery storage (MW)	Not needed	
	Grid Enhancing Technology	Not needed	
	Transmission upgrade including cost	Not needed	
Recommended Mitigation		Existing Big Creek-San Joaquin Valley RAS	

Table F.11-27: North of Magunden constraint affected inerties

Affected inerties	N/A	
	HSN	SSN
MIC expansion request MW behind constraint	N/A	N/A
Deliverable MIC expansion request MW	N/A	N/A

Whirlwind 500/230 kV Transformer Constraint

The deliverability of FC resources interconnecting at Whirlwind 230 kV buses is limited by thermal overloading of the 500/230 kV transformers under Category P1 conditions as shown in Table F.11-28. The constraint is identified in the base portfolio under both HSN and SSN conditions, where 308 MW and 1,286 MW of capacity resources, respectively, will be undeliverable without mitigation as shown in Table F.11-29. The constraint can be mitigated by the existing Whirlwind AA Bank CRAS.

*Table F.11-28: Whirlwind 500/230 kV transformer deliverability constraint*

Overloaded Facility	Contingency	Base Portfolio Overloading (%)	
		HSN	SSN
Whirlwind #1, #3 or #4 500/230 kV transformer	Whirlwind #1, #3 or #4 500/230 kV transformer	108	120

*Table F.11-29: Whirlwind 500/230 kV transformer constraint summary*

Affected transmission zones		Tehachapi area – Whirlwind 230 kV	
		HSN	SSN
Portfolio resources behind the constraint (Installed FCDS capacity)		2,442 MW	
Generic portfolio battery storage behind the constraint (Installed FCDS capacity)		180 MW	
Deliverable portfolio resources w/o mitigation (Installed FCDS capacity)		2,134 MW	1,156 MW
Total undeliverable baseline and portfolio resources (Installed FCDS capacity)		308 MW	1,286 MW
Mitigation Options	RAS	Existing Whirlwind AA Bank CRAS	
	Reduce generic battery storage (MW)	Not needed	
	Grid Enhancing Technology	Not needed	
	Transmission upgrade including cost	Not needed	
Recommended Mitigation		Existing Whirlwind AA Bank CRAS	

Table F.11-30: Whirlwind 500/230 kV transformer constraint affected inerties

Affected inerties	N/A	
	HSN	SSN
MIC expansion request MW behind constraint	N/A	N/A
Deliverable MIC expansion request MW	N/A	N/A

### Midway–Whirlwind 500 kV Line Constraint

The deliverability of FC resources interconnecting in the Tehachapi and North of Magunden areas is limited by thermal overloading of PG&E’s portion of Midway–Whirlwind 500 kV line under Category P0 condition as shown in Table F.11-31.

The constraint is identified in the base portfolio under the HSN condition, where 646 MW of capacity resources will be undeliverable without mitigation as shown in Table F.11-32. Since the constraint occurs under normal system conditions, RAS is not a viable mitigation.

Path 26 S>N flows in the 2040 base portfolio under HSN and SSN conditions are lower than those in the 2035 cases, primarily due to load growth in Southern California. This is the main reason the quantity of undeliverable FC resources is lower in 2040 compared to 2035.

Under the 2040 HSN condition, the Path 26 S>N pre-shift flow was 1,367 MW, while the Midway–Whirlwind 500 kV line carried 1,327 MW, representing approximately 97% of the total Path 26 flow. If Path 26 S>N flows similar to those in 2035 had been modeled, the amount of undeliverable FC resources in 2040 would have been higher.

The ISO explored the alternative of removing the generic resources at Windhub substation, as detailed in the Windhub Area Export constraint, and relocating generic portfolio battery storage to other substations outside the affected transmission zone. However, this approach proved insufficient to mitigate the thermal overload. While maintaining the same Path 26 S>N pre-shift flow of 1,367 MW, the Midway–Whirlwind 500 kV line carried 1,265 MW, only a 62 MW reduction compared to the HSN case. After applying the deliverability tool, the post-shift overload would decrease only slightly, from 107% to 106%.

Under the 2040 SSN condition, the Path 26 S>N pre-shift flow was 674 MW, while the Midway–Whirlwind 500 kV line carried 1,147 MW. This indicates the presence of loop flows, as approximately 473 MW flowed N>S on the Midway–Vincent No. 1 and No. 2 500 kV lines. If higher Path 26 S>N flows had been modeled, potential deliverability concerns could have emerged under the SSN condition.

The transmission mitigation options studied for the 2040 on-peak deliverability constraint are described in section F.11.1 for the Midway – Whirlwind 500 kV line 2035 on-peak deliverability constraint.

As previously mentioned, upgrading Path 26 in the south-to-north direction will lead to increased flows and cause additional stress on Path 15, a more comprehensive analysis of this concern is needed, and will be performed in the next planning cycle. In the interim, the ISO recommends congestion management as a mitigation solution for this planning cycle. Based on the expected 2026-2027 TPP portfolios, there will be an increased need for a transmission capacity expansion for Path 26 and potentially Path 15. Therefore, the ISO will continue a detailed evaluation of all potential alternatives in next year’s TPP.

Table F.11-31: Midway–Whirlwind 500 kV line deliverability constraint

Overloaded Facility	Contingency	Base Portfolio Overloading (%)	
		HSN	SSN
Midway – Whirlwind 500 kV No. 3 (PG&E Segment)	Base Case	107	<100

Table F.11-32: Midway–Whirlwind 500 kV line constraint summary

Affected transmission zones		Tehachapi and North of Magunden areas	
		HSN	SSN
Portfolio resources behind the constraint (Installed FCDS capacity)		7,121 MW	
Generic portfolio battery storage behind the constraint (Installed FCDS capacity)		433 MW	
Deliverable portfolio resources w/o mitigation (Installed FCDS capacity)		6,475 MW	7,121 MW
Total undeliverable baseline and portfolio resources (Installed FCDS capacity)		646 MW	0 MW
Mitigation Options	RAS	Not applicable	
	Reduce generic battery storage (MW)	Not sufficient	
	Grid Enhancing Technology	Reconductor PG&E segment of Midway – Whirlwind with advanced conductor	
	Transmission upgrade including cost	1. Bypass the series capacitor of the Midway – Whirlwind 500 kV line (No cost) 2. Uprate Midway – Whirlwind 500 kV line (PGE segment normal rating) (No cost) 3. Reconductor PG&E segment of Midway – Whirlwind with advanced conductor 4. Windhub – PG&E Substation 500 kV line	
		Not needed	

		5. PTEP (\$2.42B) 6. K-SEL (\$2-4B)
Recommended Mitigation		Congestion Management

Table F.11-33: Midway–Whirlwind 500 kV line constraint affected interties

Affected interties	N/A	
	HSN	SSN
MIC expansion request MW behind constraint	N/A	N/A
Deliverable MIC expansion request MW	N/A	N/A

### Pardee/Moorpark-Santa Clara Constraint

The on-peak deliverability assessment identified the thermal overload of Pardee – Santa Clara 230 kV No. 1 and Moorpark – Santa Clara 230 kV No. 2 lines under Category P7 conditions as shown in Table F.11-34. There are no generators behind the 5% DFAX circle for this constraint, and the overloads are driven by load growth in the Ventura area, which are also observed in the reliability assessment. The mitigation solutions for these concerns are detailed in Appendix B section B.4.4.4.

Table F.11-34: Pardee/Moorpark-Santa Clara deliverability constraint

Overloaded Facility	Contingency	Base Portfolio Overloading (%)	
		HSN	SSN
Pardee – Santa Clara 230 kV No. 1	Santa Clara – Moorpark 230 kV No. 1 and No. 2	122	144
Moorpark – Santa Clara 230 kV No. 2	Pardee – Santa Clara 230 kV No. 1 and Vincent – Santa Clara 230 kV No. 1	<100	109

Table F.11-35: Pardee/Moorpark-Santa Clara constraint summary

Affected transmission zones		None	
		HSN	SSN
Portfolio resources behind the constraint (Installed FCDS capacity)		No generation in 5% DFAX circle	
Generic portfolio battery storage behind the constraint (Installed FCDS capacity)			
Deliverable portfolio resources w/o mitigation (Installed FCDS capacity)			
Total undeliverable baseline and portfolio resources (Installed FCDS capacity)			
Mitigation Options	RAS	The thermal overloads were also observed in the reliability assessment. Refer to Appendix B section B.4.4.4 for the mitigation solution.	
	Reduce generic battery storage (MW)		
	Grid Enhancing Technology		
	Transmission upgrade including cost		
Recommended Mitigation			

Table F.11-36: Pardee/Moorpark-Santa Clara constraint affected inerties

Affected inerties	N/A	
	HSN	SSN
MIC expansion request MW behind constraint	N/A	N/A
Deliverable MIC expansion request MW	N/A	N/A

### F.11.3. 2040 Off-peak results

Wind and solar resources in the SCE Northern area are subject to curtailment in the base portfolio due to loading constraints identified in Table F.11-37 under normal and/or contingency conditions, which are further discussed below.

Table F.11-37: SCE Northern area off-peak deliverability constraints

Overloaded Facility	Contingency	Loading (%)
Windhub #1 or #2 500/230 kV transformer <sup>11</sup>	Windhub #1 or #2 500/230 kV transformer	129
Midway – Whirlwind 500 kV No. 3 (PG&E Segment)	Base Case	108
Whirlwind #1, #3 or #4 500/230 kV transformer	Whirlwind #1, #3 or #4 500/230 kV transformer	105

Windhub 500/230 kV transformers off-peak deliverability constraint

Wind and solar resources interconnecting to Windhub 230 kV Bus A are subject to curtailment in the base portfolio due to loading limitations of the Windhub 500/230 kV transformers under Category P1 conditions, as shown above. About 692 MW of portfolio resources were curtailed to mitigate the overload as presented in Table F.11-38. Pre-contingency curtailment can be avoided by relying on the existing Windhub AA Bank CRAS.

Table F.11-38: Windhub 500/230 kV transformers off-peak deliverability constraint summary

Affected renewable transmission zones		Tehachapi area – Windhub 230 kV Bus A
Portfolio solar and wind resources behind the constraint		354 MW
Portfolio energy storage behind the constraint		1,089 MW
Renewable curtailment without mitigation		692 MW
Mitigation Options	Portfolio ES (in charging mode) <sup>12</sup>	401 MW
	RAS	Existing Windhub AA Bank CRAS
	Grid Enhancing Technology	Not needed
	Transmission upgrades	Not needed
Recommended Mitigation		Existing Windhub AA Bank CRAS

<sup>11</sup> Depending on which Windhub 230 kV bus, Bus A or Bus B, generic portfolio resources are mapped to, could overload Banks #3 and #4 500/230 kV transformers.

<sup>12</sup> The Portfolio energy storage (in charging mode) amount is the amount needed to mitigate the constraint after baseline battery storage is fully utilized.

Midway–Whirlwind 500 kV line off-peak deliverability constraint

Wind and solar resources in the Tehachapi and North of Magunden areas are subject to curtailment in the base portfolio due to loading limitations on PG&E’s portion of the Midway–Whirlwind 500 kV line under normal conditions, as described in previous sections. About 420 MW of portfolio resources were curtailed to mitigate the overload as presented in Table F.11-39. The constraint occurs during periods of high renewable output even with moderate S>N transfers on Path 26, where renewable curtailment can be avoided by reducing thermal generation and dispatching baseline energy storage in charging mode. Since the constraint occurs under normal system conditions, RAS is not a viable mitigation.

The 2040 off-peak case exhibited a Path 26 S>N flow of 1,955 MW, while the Midway–Whirlwind 500 kV line carried 1,706 MW, representing approximately 87% of the total Path 26 flow. If higher Path 26 S>N flows had been modeled, increased levels of renewable curtailment would have been identified, which would have required additional mitigation measures including the dispatch of portfolio energy storage resources in charging mode.

The transmission mitigation options studied for the off-peak deliverability constraint are described in section F.11.1 for the Midway – Whirlwind 500 kV line 2035 on-peak deliverability constraint. Based on the above considerations, dispatching energy storage in charging mode is found to be the preferred solution to address the off-peak deliverability constraint at this time.

*Table F.11-39: Midway–Whirlwind 500 kV line off-peak deliverability constraint summary*

Affected renewable transmission zones		Tehachapi and North of Magunden areas
Portfolio solar and wind resources behind the constraint		3,682 MW
Portfolio energy storage behind the constraint		3,799 MW
Renewable curtailment without mitigation		420 MW
Mitigation Options	Portfolio ES (in charging mode) <sup>13</sup>	0 MW
	RAS	Not applicable for P0 overload
	Grid Enhancing Technology	Reconductor PG&E segment of Midway – Whirlwind with advanced conductor
	Transmission upgrades	1. Bypass the series capacitor of the Midway – Whirlwind 500 kV line 2. Uprate Midway – Whirlwind 500 kV line (PGE segment normal rating)

<sup>13</sup> The Portfolio energy storage (in charging mode) amount is the amount needed to mitigate the constraint after baseline battery storage is fully utilized.

		<ul style="list-style-type: none"> <li>3. Reconductor PG&amp;E segment of Midway – Whirlwind with advanced conductor</li> <li>4. Windhub – PG&amp;E Substation 500 kV line</li> <li>5. PTEP (\$2.42B)</li> <li>6. K-SEL (\$2-4B)</li> </ul>
Recommended Mitigation		Dispatch energy storage in charging mode

Whirlwind 500/230 kV transformers off-peak deliverability constraint

Wind and solar resources interconnecting to Whirlwind 230 kV bus are subject to curtailment in the base portfolio due to loading limitations of the Whirlwind 500/230 kV transformers under Category P1 conditions, as shown above. About 137 MW of portfolio resources were curtailed to mitigate the overload as presented in Table F.11-40. Pre-contingency curtailment can be avoided by relying on the existing Whirlwind AA Bank CRAS.

*Table F.11-40: Whirlwind 500/230 kV transformers off-peak deliverability constraint summary*

Affected renewable transmission zones		Tehachapi area – Whirlwind 230 kV
Portfolio solar and wind resources behind the constraint		1,025 MW
Portfolio energy storage behind the constraint		1,447 MW
Renewable curtailment without mitigation		137 MW
Mitigation Options	Portfolio ES (in charging mode) <sup>14</sup>	0 MW
	RAS	Existing Whirlwind AA Bank CRAS
	Grid Enhancing Technology	Not needed
	Transmission upgrades	Not needed
Recommended Mitigation		Existing Whirlwind AA Bank CRAS

<sup>14</sup> The Portfolio energy storage (in charging mode) amount is the amount needed to mitigate the constraint after baseline battery storage is fully utilized.

#### F.11.4. Conclusion and recommendation

The SCE Northern area base and sensitivity portfolios deliverability assessment identified on-peak and off-peak deliverability constraints. The Windhub and Whirlwind 500/230 kV transformer constraints, and the North of Magunden constraint can be addressed by using CRAS or RAS, respectively.

The deliverability assessment identified the Pardee/Moorpark–Santa Clara constraint in the 2040 on-peak scenarios. This constraint is driven by load growth in the Ventura area rather than resource delivery; therefore, the mitigation solution is addressed in the reliability assessment.

The CPUC did not expect to trigger transmission upgrades for Path 26 and Windhub Area Export constraints in the 2025-2026 TPP portfolios. In the interim, the ISO recommends congestion management as the mitigation solution for the Midway–Whirlwind 500 kV line constraint and agrees with the CPUC on the removal of generic resources at Windhub substation from the portfolios, to avoid triggering a transmission upgrade for the Windhub Area Export constraint due to additional in-development resources modeled by the PTO.

Based on the expected 2026-2027 TPP portfolios, the need for a transmission capacity expansion for Path 26 and potentially Path 15 is expected to increase. Accordingly, the ISO will continue a detailed evaluation of all potential alternatives in next year's TPP.

In consequence, transmission upgrades were not found to be needed in the area in the current planning cycle.

## F.12. SCE North of Lugo Area

The total capacity of resources, by resource type, selected with Full Capacity Deliverability Status (FCDS) as well as those selected as Energy Only (EO) in the SCE North of Lugo (NOL) interconnection area are listed in Table F.12-1. The portfolio in the interconnection area is comprised of solar, battery storage, geothermal, biomass/biogas and distributed solar resources. All portfolio resources are modeled in policy-driven assessments except in the on-peak deliverability assessment in which only FCDS resources are modeled.

*Table F.12-1: SCE North of Lugo Interconnection Area – Base and Sensitivity Portfolios by Resource Types (FCDS, EO and Total)*

Resource Type	2035 Base Portfolio			2040 Base Portfolio			2035 Sensitivity Portfolio		
	FCDS (MW)	EO (MW)	Total (MW)	FCDS (MW)	EO (MW)	Total (MW)	FCDS (MW)	EO (MW)	Total (MW)
Solar	650	524	1,174	750	1,243	1,993	575	390	965
Wind – In State	330	32	362	330	32	362	330	32	362
Wind – Out-of-State	0	0	0	0	0	0	0	0	0
Wind - Offshore	0	0	0	0	0	0	0	0	0
Li Battery – 4 hr	557	0	557	557	0	557	557	0	557
Li Battery – 8 hr	103	0	103	453	0	453	6	0	6
Long Duration Energy Storage (LDES)	0	0	0	0	0	0	0	0	0
Geothermal	20	0	20	30	0	30	20	0	20
Biomass/Biogas	5	0	5	5	0	5	5	0	5
Distributed Solar	0	24	24	0	24	24	0	24	24
<b>Total</b>	<b>1,665</b>	<b>580</b>	<b>2,245</b>	<b>2,125</b>	<b>1,299</b>	<b>3,424</b>	<b>1,493</b>	<b>446</b>	<b>1,939</b>

The base portfolio resources as identified in the CPUC busbar mapping for the SCE North of Lugo interconnection area are illustrated on the single-line diagram in Figure F.12-1 and Figure F.12-2.

Figure F.12-1: SCE North of Lugo Interconnection Area – Mapped 2035 Base Portfolio

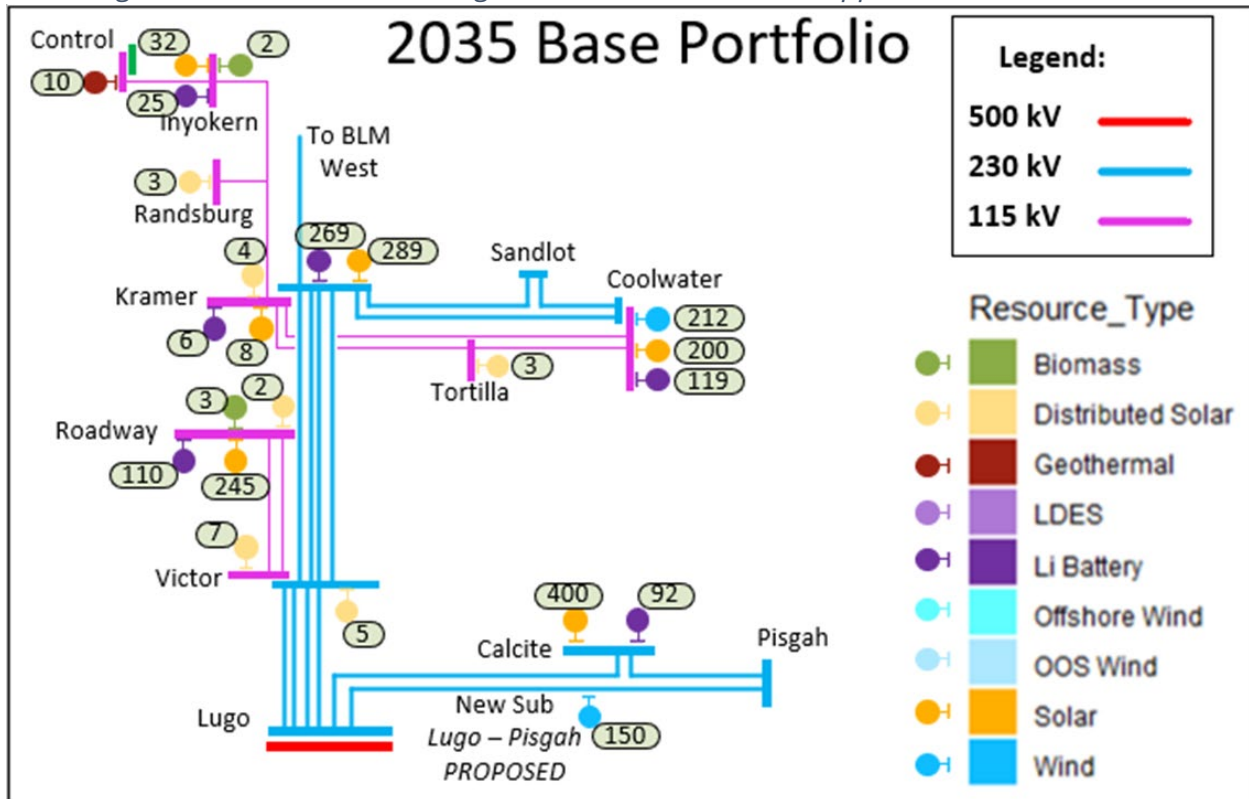
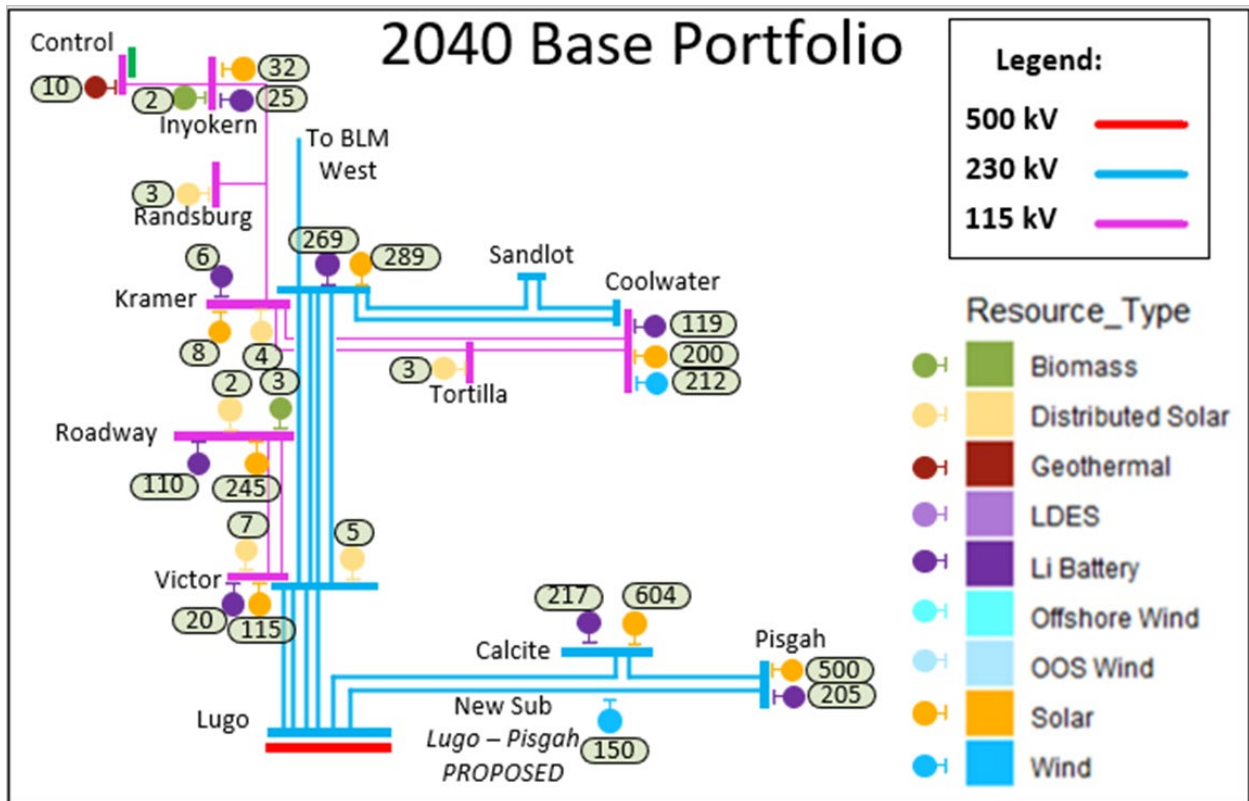

Figure F.12-2: SCE North of Lugo Interconnection Area – Mapped 2040 Base Portfolio



### F.12.1. 2035 On-peak results

#### Coolwater–Kramer Corridor Constraint

The Coolwater–Kramer corridor deliverability constraint, which is comprised of the constraints included in Table F.12-2, affect deliverability of capacity resources in the NOL area due to thermal overloading of the planned 230/115 kV transformer and 115 kV lines in the area under contingency conditions as shown in the table. Up to 395 MW of capacity resources in the base portfolio will be undeliverable without mitigation.

Table F.12-3 provides the constraint summary for the more limiting constraints.

*Table F.12-2: Coolwater–Kramer corridor on-peak deliverability constraint*

Overloaded Facility	Contingency	Loading (%)	
		Base	Sensitivity
Coolwater - Tap 705 115kV	Kramer–Coolwater & Sandlot–Coolwater 230 kV lines	138	136
Tap 705 - Tortilla 115kV		137	135
Coolwater Transformer #1	Kramer–Coolwater & Sandlot–Coolwater 230 kV lines	117	117

*Table F.12-3: On-peak Coolwater–Kramer corridor constraint summary*

Affected transmission zones		NOL area	
		Base	Sensitivity
Portfolio resources behind the constraint (Installed FCDS capacity)		450 MW	395 MW
Generic portfolio battery storage behind the constraint (Installed FCDS capacity)		5 MW	N/A
Deliverable portfolio resources w/o mitigation (Installed FCDS capacity)		55 MW	52 MW
Total undeliverable baseline and portfolio resources (Installed FCDS capacity)		395 MW	343 MW
Mitigation Options	RAS	Mohave Desert RAS	Mohave Desert RAS
	Reduce generic battery storage (MW)	Not Needed	Not Needed
	Grid Enhancing Technology	Not Needed	Not Needed
	Transmission upgrade including cost	N/A	N/A
Recommended Mitigation		Mohave Desert RAS	Mohave Desert RAS

The Coolwater–Kramer corridor constraint was not found to impact MIC expansion requests as shown in Table F.12-4.

Table F.12-4: On-peak Coolwater–Kramer corridor constraint affected interties

Affected interties	N/A
MIC expansion request MW behind constraint	N/A
Deliverable MIC expansion request MW	N/A

Remedial Action Schemes (RAS), reducing generic portfolio battery storage and transmission alternatives were considered to address the constraints. Since the existing Mohave Desert RAS adequately mitigates the deliverability constraints, no other solution was found to be needed.

### Lugo–Calcite–Pisgah 230 kV Corridor Constraint

Resources at Calcite and Pisgah will be subject to curtailment due to loading limitations on the Calcite–Pisgah 230 kV line under contingency conditions as shown in Table F.12-5. Table F.12-6 provides summary of the constraints including mitigation alternatives considered. The constraints can be mitigated by the planned Calcite CRAS or dispatching generic portfolio battery storage in charging mode.

Table F.12-5: Lugo–Calcite–Pisgah 230 kV corridor on-peak deliverability constraint

Overloaded Facility	Contingency	Loading (%)	
		Base	Sensitivity
Calcite- Lugo #1 230kV line	Pisgah – Lugo #2 230kV line	100	<100

Table F.12-6: Lugo–Calcite–Pisgah 230 kV corridor on-peak deliverability constraint summary

Affected transmission zones		Calcite and Pisgah Substations	
		Base	Sensitivity
Portfolio resources behind the constraint (Installed FCDS capacity)		177 MW	N/A
Generic portfolio battery storage behind the constraint (Installed FCDS capacity)		92 MW	N/A
Deliverable portfolio resources w/o mitigation (Installed FCDS capacity)		175 MW	N/A
Total undeliverable baseline and portfolio resources (Installed FCDS capacity)		2 MW	N/A
Mitigation Options	RAS	Planned Calcite CRAS	N/A

	Reduce generic battery storage (MW)	2 MW	N/A
	Grid Enhancing Technology	Not Needed	N/A
	Transmission upgrade including cost	Not Needed	N/A
Recommended Mitigation		Planned Calcite CRAS	N/A

The constraint was not found to impact MIC expansion requests in the area as indicated in Table F.12-7.

Table F.12-7: On-peak Lugo–Calcite–Pisgah 230 kV corridor constraint affected inerties

Affected inerties	N/A
MIC expansion request MW behind constraint	N/A
Deliverable MIC expansion request MW	N/A

### F.12.2. 2040 On-peak results

#### Lugo–Calcite–Pisgah 230 kV Corridor Constraint

Resources at Calcite and Pisgah will be subject to curtailment due to loading limitations on the Calcite–Pisgah and Calcite-Lugo 230 kV lines under contingency conditions as shown in Table F.12-9 provides summary of the constraints including total undeliverable baseline and portfolio resources with and without the Calcite CRAS along with mitigation alternatives. Up to 705 MW of capacity resources in the base portfolio will be undeliverable without mitigation.

Table F.12-8: Lugo–Calcite–Pisgah 230 kV corridor on-peak deliverability constraint

Overloaded Facility	Contingency	Base Portfolio Overloading (%)	
		HSN	SSN
Calcite - Lugo #1 230kV line	Pisgah – Lugo #2 230kV line	181	170
Calcite - Lugo #1 230kV line	Lugo - Victorville #1 500kV line	158	147
	El Dorado - Lugo #1 500kV line	155	145
	Base Case	141	132
Calcite - Pisgah #1 230kV line	Calcite - Lugo #1 230kV line	108	101

Table F.12-9: Lugo–Calcite–Pisgah 230 kV corridor on-peak deliverability constraint summary

Affected transmission zones		Calcite and Pisgah Substations	
		HSN	SSN
Portfolio resources behind the constraint (Installed FCDS capacity)		871 MW	871 MW
Generic portfolio battery storage behind the constraint (Installed FCDS capacity)		422 MW	422 MW
Deliverable portfolio resources w/o mitigation (Installed FCDS capacity)		166 MW	170 MW
Total undeliverable baseline and portfolio resources (curtailment with RAS)		705 MW (150 MW)	701 MW (146 MW)
Mitigation Options	RAS	Planned Calcite CRAS (NA for P0 scenario)	Planned Calcite CRAS (NA for P0 scenario)
	Reduce generic battery storage (MW)	Relocate generic battery storage	Relocate generic battery storage
	Grid Enhancing Technology	Reconductor Lugo – Calcite and Lugo-Pisgah 230kV lines with advanced conductor	Reconductor Lugo – Calcite and Lugo-Pisgah 230kV lines with advanced conductor
	Transmission upgrade including cost	Rebuild Lugo – Calcite and Lugo-Pisgah 230kV lines (Cost \$466-\$868M)	Rebuild Lugo – Calcite and Lugo-Pisgah 230kV lines (Cost \$466-\$868M)
Recommended Mitigation		1. For P0 overloads, relocate generic battery storage behind the constraint. 2. For all other contingency events, utilize planned Calcite CRAS and relocate battery/charge as needed.	1. For P0 overloads, relocate generic battery storage behind the constraint. 2. For all other contingency events, utilize planned Calcite CRAS and relocate battery/charge as needed.

Remedial Action Schemes (RAS), reducing generic portfolio battery storage and transmission alternatives were considered to address the constraints. Since the existing Calcite CRAS is not adequate to mitigate the deliverability constraints, relocation of battery storage will be needed.

The constraint was not found to impact MIC expansion requests in the area as indicated in Table F.12-10.

Table F.12-10: On-peak Lugo–Calcite–Pisgah 230 kV corridor constraint affected inerties

Affected inerties	N/A
MIC expansion request MW behind constraint	N/A
Deliverable MIC expansion request MW	N/A

### Coolwater–Kramer Corridor Constraint

The Coolwater–Kramer corridor deliverability constraint, which is comprised of the constraints included in Table F, affect deliverability of capacity resources in the NOL area due to thermal overloading of the planned 230/115 kV transformer and 115 kV lines in the area under contingency conditions as shown in the table. Up to 407 MW of capacity resources in the base portfolio will be undeliverable without mitigation. Table F.12-11 provides the constraint summary for the more limiting constraints.

Table F.12-11: Coolwater-Kramer corridor on-peak deliverability constraint

Overloaded Facility	Contingency	Base Portfolio Overloading (%)	
		HSN	SSN
Coolwater - Tap 705 115kV	Kramer–Coolwater & Sandlot–Coolwater 230 kV lines	139	185
Tap 705 - Tortilla 115kV		138	179
Coolwater Transformer #1	Kramer–Coolwater & Sandlot–Coolwater 230 kV lines	120	167
Sandlot - Kramer #1 230 kV line	Kramer–Coolwater #2 230 kV line	<100	133
Kramer–Coolwater #2 230 kV line	Sandlot - Kramer #1 230 kV line	<100	125
Tortilla - Kramer #2 115 kV line	Kramer–Coolwater & Sandlot–Coolwater 230 kV lines	<100	105
Tortilla - Kramer #1 115 kV line		<100	104

Table F.12-12: On-peak Coolwater–Kramer corridor constraint summary

Affected transmission zones		NOL area	
		HSN	SSN
Portfolio resources behind the constraint (Installed FCDS capacity)		450 MW	450 MW
Generic portfolio battery storage behind the constraint (Installed FCDS capacity)		5 MW	5 MW
Deliverable portfolio resources w/o mitigation (Installed FCDS capacity)		43 MW	0 MW
Total undeliverable baseline and portfolio resources (Installed FCDS capacity)		407 MW	450 MW
Mitigation Options	RAS	Mohave Desert RAS	Mohave Desert RAS

	Reduce generic battery storage (MW)	Not Needed	Not Needed
	Grid Enhancing Technology	Not Needed	Not Needed
	Transmission upgrade including cost	N/A	N/A
Recommended Mitigation		Mohave Desert RAS	Mohave Desert RAS

Remedial Action Schemes (RAS), reducing generic portfolio battery storage and transmission alternatives were considered to address the constraints. Since the existing Mohave Desert RAS adequately mitigates the deliverability constraints, no other solution was found to be needed.

The Coolwater–Kramer corridor constraint was not found to impact MIC expansion requests as shown in Table F.12-13.

Table F.12-13: On-peak Coolwater–Kramer corridor constraint affected inerties

Affected inerties	N/A
MIC expansion request MW behind constraint	N/A
Deliverable MIC expansion request MW	N/A

### F.12.3. 2040 Off-peak results

#### Lugo–Calcite–Pisgah 230 kV Corridor Constraint

Resources at Calcite and Pisgah will be subject to curtailment due to loading limitations on the Calcite–Pisgah 230 kV line under contingency conditions as shown in Table F.12-14. Table F.12-15 provides summary of the constraints including total undeliverable baseline and portfolio resources with and without the Calcite CRAS along with mitigation alternatives. Up to 592 MW of capacity resources in the base portfolio will be undeliverable without mitigation.

Table F.12-14: Lugo–Calcite–Pisgah 230 kV corridor on-peak deliverability constraint

Overloaded Facility	Contingency	Loading (%)
Calcite - Lugo #1 230kV line	Pisgah- Lugo #2 230kV line	238

	Base Case	195
Pisgah – Lugo #2 230kV line	Calcite - Lugo #1 230kV line	187
Calcite - Pisgah #1 230kV line		186

Table F.12-15: Lugo–Calcite–Pisgah 230 kV corridor off-peak deliverability constraint summary

Affected renewable transmission zones		Calcite and Pisgah Substations
Portfolio solar and wind resources behind the constraint		449 MW
Portfolio energy storage behind the constraint		422 MW
Renewable curtailment without mitigation (curtailment with RAS)		592 MW (37 MW)
Mitigation Options:	Portfolio ES (in charging mode) *	Not enough to mitigate the constraint
	RAS	N/A for P0 overload
	Grid Enhancing Technology	Reconductor Lugo – Calcite and Lugo- Pisgah 230kV lines with advanced conductor
	Transmission upgrades	Rebuild Lugo – Calcite and Lugo-Pisgah 230kV lines (Cost \$466-\$868M)
Recommended Mitigation		<ol style="list-style-type: none"> <li>1. For P0 overloads, relocate generic solar behind the constraint.</li> <li>2. For all other contingency events, expand planned Calcite CRAS and charge battery as available.</li> </ol>

\* The Portfolio energy storage (in charging mode) amount is the amount needed to mitigate the constraint after baseline battery storage is fully utilized.

Remedial Action Schemes (RAS), reducing generic portfolio battery storage and transmission alternatives were considered to address the constraints. Since the existing Calcite CRAS is not adequate to mitigate the deliverability constraints, relocation of generic solar will be needed.

### Coolwater–Kramer Corridor Constraint

The Coolwater–Kramer corridor deliverability constraint, which is comprised of the constraints included in Table F.12-16, affect deliverability of capacity resources in the NOL area due to thermal overloading of the planned 230/115 kV transformer and 115 kV lines in the area under contingency conditions as shown in the table. Up to 498 MW of capacity resources in the base portfolio will be undeliverable without mitigation. Table F.12-17 provides the constraint summary for the more limiting constraints.

Table F.12-16: Off-peak Coolwater-Kramer corridor deliverability constraint

Overloaded Facility	Contingency	Loading (%)
Coolwater - Tap 705 115kV	Kramer–Coolwater & Sandlot–Coolwater 230 kV lines	152
Tap 705 - Tortilla 115kV		146
Sandlot - Kramer #1 230 kV line	Kramer–Coolwater #2 230 kV line	138
Kramer–Coolwater #2 230 kV line	Sandlot - Kramer #1 230 kV line	127
Coolwater Transformer #1	Kramer–Coolwater & Sandlot–Coolwater 230 kV lines	116
Sandlot - Kramer #1 230 kV line	Coolwater - Tortilla #1 115kV line	103
	Kramer - Tortilla #2 115kV line	103
	Kramer Transformer #1 or #2	101
	Coolwater - Tortilla #2 115kV line	101

Table F.12-17: Off-peak Coolwater–Kramer corridor constraint summary

Affected renewable transmission zones		NOL area
Portfolio solar and wind resources behind the constraint		330 MW
Portfolio energy storage behind the constraint		5 MW
Renewable curtailment without mitigation		498 MW
Mitigation Options:	Portfolio ES (in charging mode) *	Not enough to mitigate the constraint
	RAS	Mohave Desert RAS
	Grid Enhancing Technology	N/A
	Transmission upgrades	N/A
Recommended Mitigation		Mohave Desert RAS

\* The Portfolio energy storage (in charging mode) amount is the amount needed to mitigate the constraint after baseline battery storage is fully utilized.

Remedial Action Schemes (RAS), reducing generic portfolio battery storage and transmission alternatives were considered to address the constraints. Since the existing Mohave Desert RAS adequately mitigates the deliverability constraints, no other solution was found to be needed.

#### F.12.4. Conclusion and recommendation

The following conclusion can be made based on the North of Lugo Area deliverability assessment:

- All portfolio resources in the NOL area are deliverable with existing or expanded Remedial Action Schemes (RAS) for 2035 Base and Sensitivity portfolio.
- 2040 On-Peak portfolio is not entirely deliverable, and relocation of generic battery/charging battery energy storage is required due to Lugo- Calcite overload (P0).
- 2040 Off-peak portfolio is not entirely deliverable, and relocation of generic solar/charging battery energy storage as available due to Lugo- Calcite overload (P0).

### F.13. SCE Eastern Area

The total capacity of resources, by resource type, selected with Full Capacity Deliverability Status (FCDS) as well as those selected as Energy Only (EO) in the SCE Eastern interconnection area are listed in Table F.13-1. The portfolios in the interconnection area are comprised of solar, wind (in-state and out-of-state), battery storage, geothermal, and biomass/biogas. All portfolio resources are modeled in policy-driven assessments except in the on-peak deliverability assessment in which only FCDS resources are modeled.

*Table F.13-1: SCE Eastern Interconnection Area – Base and Sensitivity Portfolios by Resource Types (FCDS, EO and Total)*

Resource Type	2035 Base Portfolio			2040 Base Portfolio			2035 Sensitivity Portfolio		
	FCDS (MW)	EO (MW)	Total (MW)	FCDS (MW)	EO (MW)	Total (MW)	FCDS (MW)	EO (MW)	Total (MW)
Solar	526	3,583	4,109	1,383	5,027	6,411	526	3,583	4,109
Wind – In State	287	37	325	287	37	325	287	37	325
Wind – Out-of-State	3,099	0	3,099	3,099	0	3,099	2,994	0	2,994
Wind - Offshore	0	0	0	0	0	0	0	0	0
Li Battery – 4 hr.	7,891	0	7,891	7,561	0	7,561	8,336	0	8,336
Li Battery – 8 hr.	166	0	166	536	0	536	166	0	166
Long Duration Energy Storage (LDES)	0	0	0	0	0	0	200	0	200
Geothermal	500	0	500	500	0	500	557	0	557
Biomass/Biogas	8	0	8	8	0	8	8	0	8
Distributed Solar	0	0	0	0	0	0	0	0	0
<b>Total</b>	<b>12,477</b>	<b>3,620</b>	<b>16,098</b>	<b>13,374</b>	<b>5,064</b>	<b>18,440</b>	<b>13,074</b>	<b>3,620</b>	<b>16,695</b>

The resources as identified in the CPUC busbar mapping for the SCE Eastern interconnection area are illustrated on the single-line diagrams below.

Figure 13-1: SCE Eastern Interconnection Area – Mapped 2035 Base Portfolio

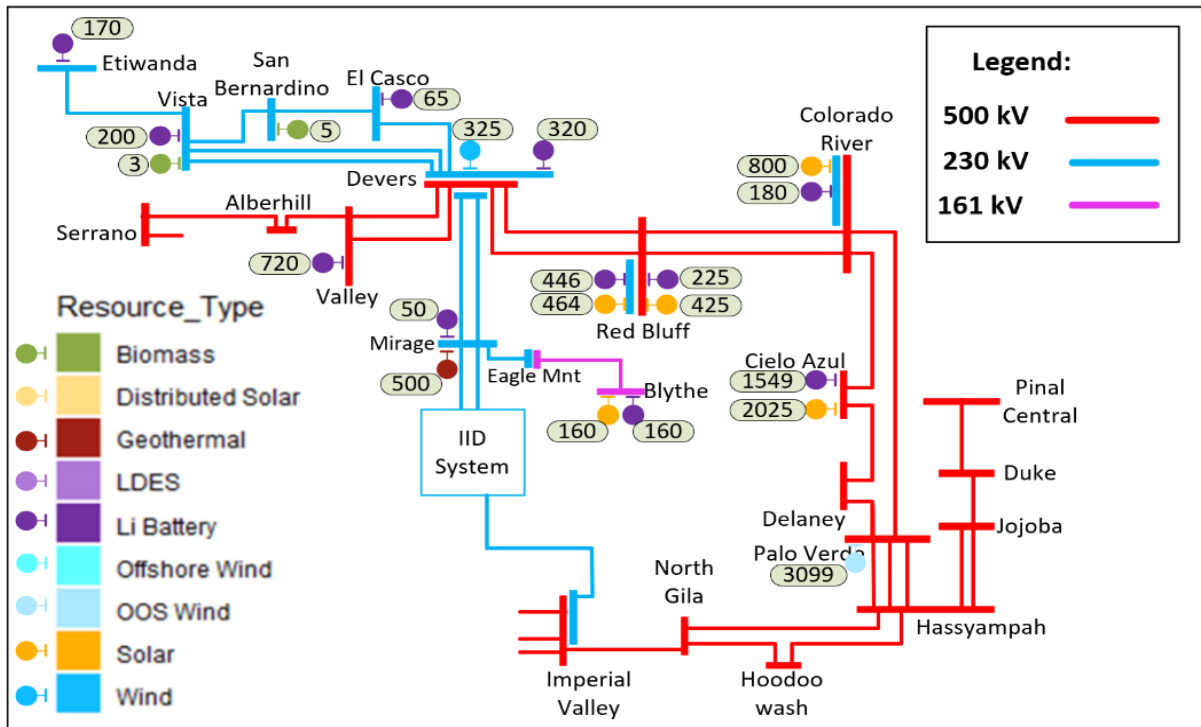

Figure F.13-2: SCE Eastern Interconnection Area – Mapped 2040 Base Portfolio

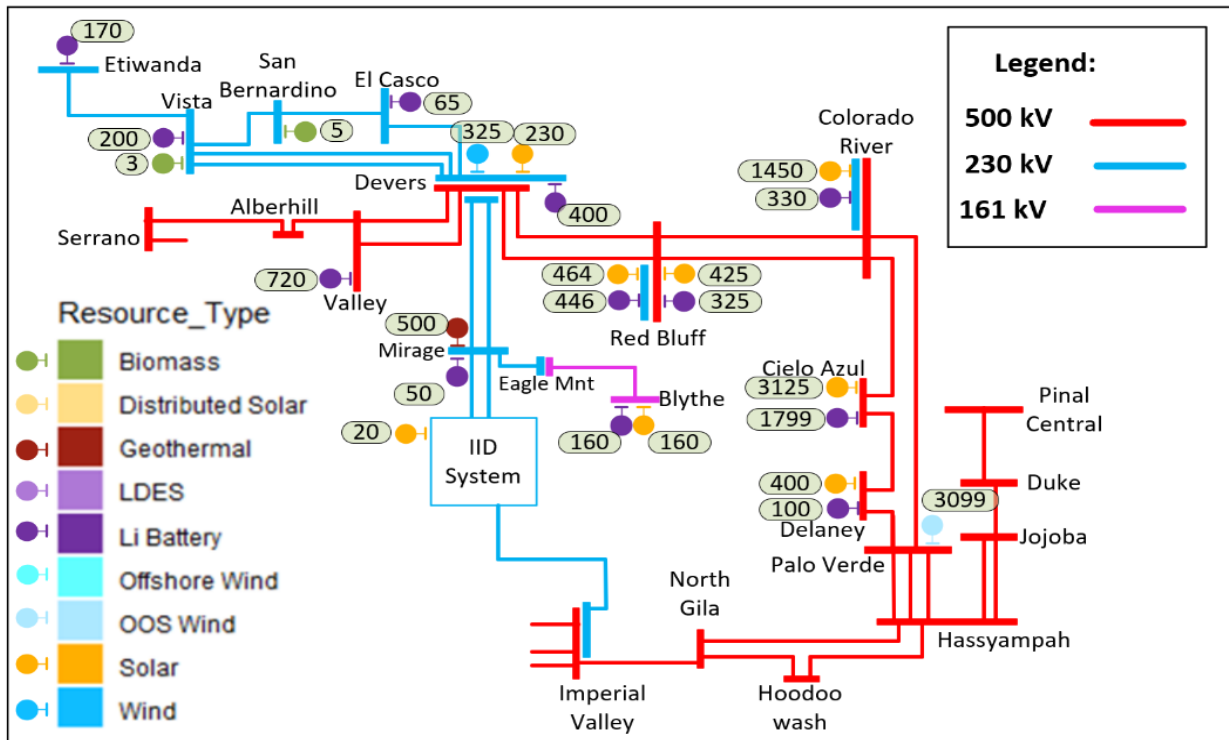
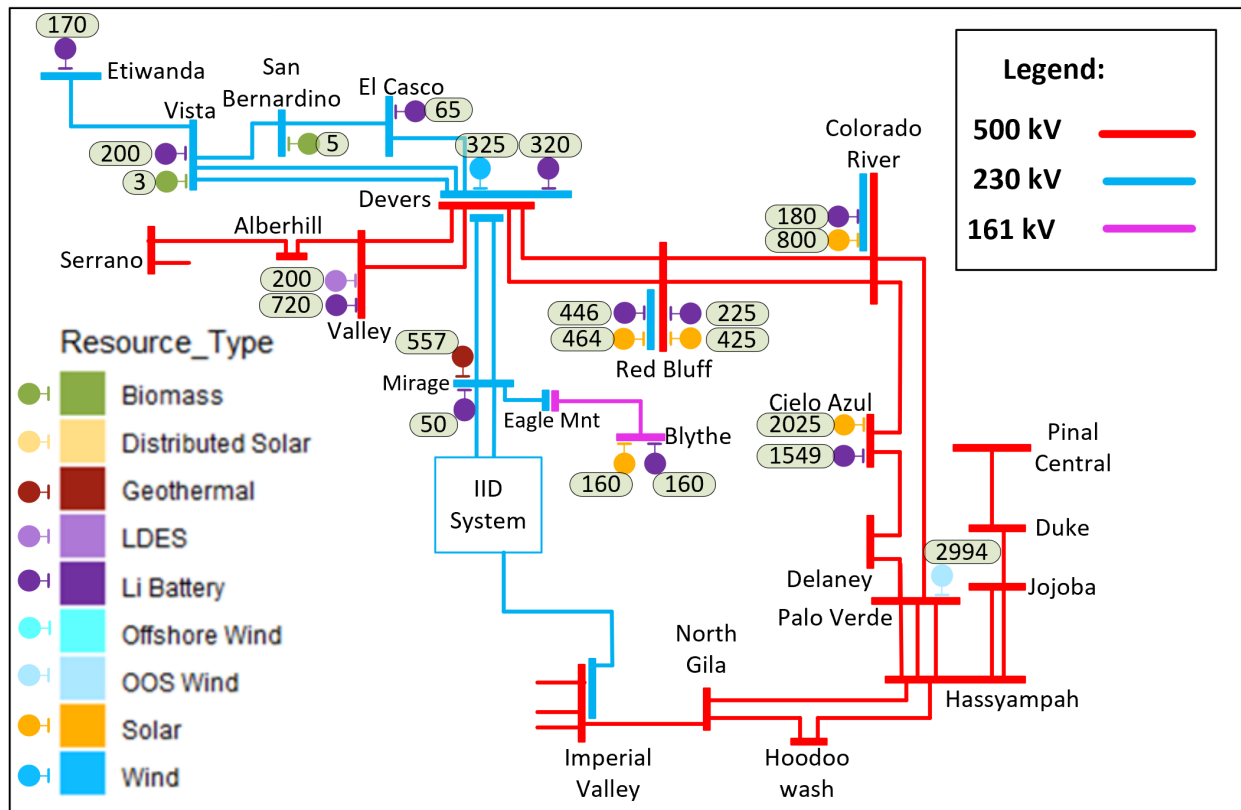

Figure F.13-3: SCE Eastern Interconnection Area – Mapped 2035 Sensitivity Portfolio



### F.13.1. 2035 On-peak results

#### Colorado River 500/230 kV Constraint

The deliverability of full capacity resources interconnecting at the Colorado River 230 kV bus is limited by thermal overloading of the 500/230 kV transformers under Category P1 conditions as shown in Table F.13-2. The constraint was observed in both the base and sensitivity portfolios under the HSN scenario. Table F.13-3 shows the amount of generation that would be undeliverable without mitigation. The constraint can be mitigated by the existing West of Colorado River CRAS.

Table F.13-2: Colorado River 500/230 kV 2035 on-peak deliverability constraint

Overloaded Facility	Contingency	Loading (%)	
		Base	Sensitivity
Colorado River 500/230 kV Transformer No.1	Colorado River 500/230 kV Transformer No.2	149	149
Colorado River 500/230 kV Transformer No.2	Colorado River 500/230 kV Transformer No.1	149	149

Table F.13-3: Colorado River 500/230 kV 2035 on-peak constraint summary

Affected transmission zones		Colorado River 230 kV	
		Base	Sensitivity
Portfolio resources behind the constraint (Installed FCDS capacity)		794 MW	794 MW
Generic portfolio battery storage behind the constraint (Installed FCDS capacity)		30 MW	30 MW
Deliverable portfolio resources w/o mitigation (Installed FCDS capacity)		0 MW	0 MW
Total undeliverable baseline and portfolio resources (Installed FCDS capacity)		938 MW	938 MW
Mitigation Options	RAS	Existing West of Colorado River CRAS	
	Reduce generic battery storage (MW)	Not needed	
	Grid Enhancing Technology	Not needed	
	Transmission upgrade including cost	Not needed	
Recommended Mitigation		Existing West of Colorado River CRAS	

Affected interties	N/A
MIC expansion request MW behind constraint	N/A
Deliverable MIC expansion request MW	N/A

### Red Bluff 500/230 kV Constraint

The deliverability of full capacity resources interconnecting at the Red Bluff 230 kV bus is limited by thermal overloading of the 500/230 kV transformers under Category P1 conditions as shown in Table F.13-3. The constraint was observed in both the base and sensitivity portfolios under the HSN scenario. Table F.13-4 shows the amount of generation that would be undeliverable without mitigation. The constraint can be mitigated by the existing West of Colorado River CRAS.

Table F.13-3: Red Bluff 500/230 kV 2035 on-peak deliverability constraint

Overloaded Facility	Contingency	Loading (%)	
		Base	Sensitivity
Red Bluff 500/230 kV Transformer No.1	Red Bluff 500/230 kV Transformer No.2	129	129
Red Bluff 500/230 kV Transformer No.2	Red Bluff 500/230 kV Transformer No.1	129	129

Table F.13-4: Red Bluff 500/230 kV 2035 on-peak constraint summary

Affected transmission zones		Red Bluff 230 kV	
		Base	Sensitivity
Portfolio resources behind the constraint (Installed FCDS capacity)		961 MW	961 MW
Generic portfolio battery storage behind the constraint (Installed FCDS capacity)		0 MW	0 MW
Deliverable portfolio resources w/o mitigation (Installed FCDS capacity)		559 MW	559 MW
Total undeliverable baseline and portfolio resources (Installed FCDS capacity)		402 MW	402 MW
Mitigation Options	RAS	Existing West of Colorado River CRAS	
	Reduce generic battery storage (MW)	Not needed	
	Grid Enhancing Technology	Not needed	
	Transmission upgrade including cost	Not needed	
Recommended Mitigation		Existing West of Colorado River CRAS	

Affected inerties	N/A
MIC expansion request MW behind constraint	N/A
Deliverable MIC expansion request MW	N/A

Devers-Red Bluff Constraint

The deliverability of full capacity resources in the SCE Eastern and SDG&E areas is limited by thermal overloading of the Devers-Red Bluff 500 kV lines under Category P1 conditions as shown in Table F.13-5. The constraint was observed in both the base and sensitivity portfolios under the HSN scenario. Furthermore, the PALOVRDE\_ITC (PVWEST) MIC expansion request is behind this constraint, and the expansion request is undeliverable. Table F.13-6 shows the amount of generation that would be undeliverable without mitigation. The constraint can be mitigated by the existing West of Colorado River CRAS in 2035.

*Table F.13-5: Devers-Red Bluff 2035 on-peak deliverability constraint*

Overloaded Facility	Contingency	Loading (%)	
		Base	Sensitivity
Devers – Red Bluff 500 kV No.1	Devers – Red Bluff 500 kV No.2	106	106
Devers – Red Bluff 500 kV No.2	Devers – Red Bluff 500 kV No.1	106	106

*Table F.13-6: Devers-Red Bluff 2035 on-peak constraint summary*

Affected transmission zones		SCE Eastern (east of Red Bluff) and SDG&E	
		Base	Sensitivity
Portfolio resources behind the constraint (Installed FCDS capacity)		6052 MW	4367 MW
Generic portfolio battery storage behind the constraint (Installed FCDS capacity)		119 MW	119 MW
Deliverable portfolio resources w/o mitigation (Installed FCDS capacity)		4710 MW	3109 MW
Total undeliverable baseline and portfolio resources (Installed FCDS capacity)		1342 MW	1258 MW
Mitigation Options	RAS	Existing West of Colorado River CRAS	
	Reduce generic battery storage (MW)	Not needed	
	Grid Enhancing Technology	Not needed	
	Transmission upgrade including cost	Not needed	
Recommended Mitigation		Existing West of Colorado River CRAS	

Affected interties	PALOVRDE_ITC (PVWEST)
MIC expansion request MW behind constraint	551 nameplate wind
Deliverable MIC expansion request MW	0

### Serrano-Alberhill-Valley Constraint

The deliverability of full capacity resources in the SCE Eastern and SDG&E areas is limited by thermal overloading of lines and transformers as shown in Table F.13-7. The constraint was only observed in the sensitivity portfolio under the HSN scenario. Furthermore, the PALOVRDE\_ITC (PVWEST) MIC expansion request is behind this constraint, and the expansion request is undeliverable in the sensitivity portfolio. Table F.13-8 shows the amount of generation that would be undeliverable without mitigation.

Based on the RAS guidelines (ISO G-RAS2) stated in the California ISO Planning Standards<sup>15</sup>, the existing Inland Devers Extension CRAS cannot be expanded to monitor overloads on Devers transformers. Reducing generic battery storage and using grid enhancing technologies are also not considered to be viable solutions. To fully mitigate this constraint in the sensitivity portfolio, a transmission upgrade such as installing another 500/230 kV transformer at Devers was considered. However, since the need for this upgrade was only identified for the sensitivity portfolio, the upgrade is not recommended at this time.

While RAS is also not allowed to address a base case overload, the overloads on the Serrano-Alberhill-Valley 500 kV line are marginal and no major transmission upgrade is recommended at this time. The Inland Devers Extension CRAS and/or congestion management can be used to handle N-1 and N-2 contingencies.

The ISO will continue to monitor this constraint in future planning cycle(s) and re-evaluate the mitigation options if needed.

---

<sup>15</sup> <https://www.caiso.com/Documents/ISO-Planning-Standards-Effective-Feb22023.pdf>

Table F.13-7: Serrano-Alberhill-Valley 2035 on-peak deliverability constraint

Overloaded Facility	Contingency	Loading (%)	
		Base	Sensitivity
Devers 500/230 kV Transformer No. 1	Serrano-Alberhill-Valley 500 kV No.1	<100	103
Devers 500/230 kV Transformer No. 2		<100	101
Serrano-Alberhill-Valley 500 kV No.1	Devers-Vista 230 kV No.1 & No.2	<100	102
	Etiwanda-San Bernardino 230 kV & Vista-San Bernardino 230 kV	<100	101
	Devers-El Casco 230 kV & Devers-San Bernardino 230 kV	<100	100
	Base Case	<100	100

Table F.13-8: Serrano-Alberhill-Valley 2035 on-peak constraint summary

Affected transmission zones		SCE Eastern, SDG&E, IID	
		Base	Sensitivity
Portfolio resources behind the constraint (Installed FCDS capacity)			7861 MW
Generic portfolio battery storage behind the constraint (Installed FCDS capacity)			30 MW
Deliverable portfolio resources w/o mitigation (Installed FCDS capacity)			7712 MW
Total undeliverable baseline and portfolio resources (Installed FCDS capacity)			149 MW
Mitigation Options	RAS	N/A	Inland Devers Extension CRAS cannot be expanded to monitor overloads on Devers transformers.
	Reduce generic battery storage (MW)		RAS not allowed to address Base Case overload.
	Grid Enhancing Technology		Not sufficient
	Transmission upgrade including cost		Not applicable
Recommended Mitigation			New Devers No.3 500/230 kV transformer (\$141-\$193 million)
			Transmission upgrades only needed for sensitivity case

Affected interties	PALOVRDE_ITC (PVWEST)
MIC expansion request MW behind constraint	551 nameplate wind
Deliverable MIC expansion request MW	0

### Blythe Constraint

The deliverability of full capacity resources in the Blythe area is limited by thermal overloading of the Blythe SCE-WAPA 161 kV tie-line as shown in Table F.13-9. The constraint was observed in both the base and sensitivity portfolios under the HSN scenario. This constraint is driven by the BLYTHE\_ITC MIC, which is partly deliverable in 2035, and rapid load growth in the Blythe area. It is also potentially attributed to loop flow issues from neighboring jurisdictions. Table F.13-10 shows the amount of generation that would be undeliverable without mitigation.

RAS and reducing generic battery storage are not applicable solutions, as it wouldn't meet the ISO RAS guidelines and there is no generic storage in the area. Upgrading the rating of the tie-line was considered, however, this option would require a WECC path rating study given that the line is WECC Path 59. Furthermore, low-voltage issues in the Blythe area were identified in the reliability studies for this planning cycle as load is projected to grow rapidly in the region. SCE is currently conducting a method of service study to address these issues. Once the preferred method of service is identified, SCE will be seeking ISO approval on the proposed network upgrades.

No transmission upgrade to address deliverability issues is recommended at this time. The ISO will continue to monitor this constraint in future planning cycle(s) and re-evaluate the mitigation options in coordination with the results of SCE's method of service study.

*Table F.13-9: Blythe 2035 on-peak deliverability constraint*

Overloaded Facility	Contingency	Loading (%)	
		Base	Sensitivity
Blythe SCE-WAPA 161 kV Tie-line	Julian Hinds 220 kV Bus Section (SCE-MWD)	107	109
	Julian Hinds-Eagle Mountain 220 kV	<100	101

Table F.13-10: Blythe 2035 on-peak constraint summary

Affected transmission zones		Blythe 161 kV	
		Base	Sensitivity
Portfolio resources behind the constraint (Installed FCDS capacity)		145 MW	145 MW
Generic portfolio battery storage behind the constraint (Installed FCDS capacity)		0 MW	0 MW
Deliverable portfolio resources w/o mitigation (Installed FCDS capacity)		56 MW	28 MW
Total undeliverable baseline and portfolio resources (Installed FCDS capacity)		89 MW	117 MW
Mitigation Options	RAS	Not compliant with the ISO RAS guidelines	
	Reduce generic battery storage (MW)	Not applicable	
	Grid Enhancing Technology	To be further evaluated in future planning cycle(s)	
	Transmission upgrade including cost	1. Upgrade line rating of the Blythe SCE-WAPA Tie-line 2. Network upgrades identified as part of SCE's ongoing method of service study to address low-voltage issues in the Blythe area as load is projected to grow rapidly in the Blythe area	
Recommended Mitigation		Mitigation options to be further evaluated in future planning cycle(s), aligning with the results of SCE's Method of Service study	

Affected interties	BLYTHE_ITC	
MIC expansion request MW behind constraint	145	
Deliverable MIC expansion request MW	56	28

### F.13.2. 2040 On-peak results

#### Colorado River 500/230 kV Constraint

The deliverability of full capacity resources interconnecting at the Colorado River 230 kV bus is limited by thermal overloading of the 500/230 kV transformers under Category P1 conditions as shown in Table F.13-11. The constraint was observed under both the HSN and SSN scenarios. Table F.13-12 shows the amount of generation that would be undeliverable without mitigation.

For the HSN scenario, the constraint can be mitigated by the existing West of Colorado River CRAS. However, the CRAS alone is not sufficient for the SSN scenario since the amount of generation tripping needed exceeds the 1150 MW limit for a P1 contingency. Reducing generic battery storage and using grid enhancing technologies are also not considered to be viable solutions. To fully mitigate the constraint in the SSN scenario, a transmission upgrade such as installing another 500/230 kV transformer at Colorado River was considered.

No transmission upgrade is recommended in this planning cycle for this on-peak constraint since the need for the upgrade was only identified for the 2040 SSN scenario and no congestion on the transformers at the Colorado River substation were observed in this cycle’s economic studies. The ISO will continue to monitor the need for this upgrade in future studies and re-evaluate the mitigation options if needed.

*Table F.13-11: Colorado River 500/230 kV 2040 on-peak deliverability constraint*

Overloaded Facility	Contingency	Base Portfolio Loading (%)	
		HSN	SSN
Colorado River 500/230 kV Transformer No.1	Colorado River 500/230 kV Transformer No.2	150	163
Colorado River 500/230 kV Transformer No.2	Colorado River 500/230 kV Transformer No.1	150	163

*Table F.13-12: Colorado River 500/230 kV 2040 on-peak constraint summary*

Affected transmission zones	Colorado River 230 kV	
	HSN	SSN
Portfolio resources behind the constraint (Installed FCDS capacity)	954 MW	
Generic portfolio battery storage behind the constraint (Installed FCDS capacity)	180 MW	

Deliverable portfolio resources w/o mitigation (Installed FCDS capacity)		0 MW	0 MW
Total undeliverable baseline and portfolio resources (Installed FCDS capacity)		1101 MW	1343 MW
Mitigation Options	RAS	Existing West of Colorado River CRAS	Existing West of Colorado River CRAS alone not sufficient
	Reduce generic battery storage (MW)	Not needed	Not sufficient
	Grid Enhancing Technology	Not needed	Not applicable
	Transmission upgrade including cost	Not needed	New Colorado River No.3 500/230 kV transformer (\$67M)
Recommended Mitigation		Existing West of Colorado River CRAS	Transmission upgrades only needed for SSN case

Affected interties	N/A
MIC expansion request MW behind constraint	N/A
Deliverable MIC expansion request MW	N/A

### Red Bluff 500/230 kV Constraint

The deliverability of full capacity resources interconnecting at the Red Bluff 230 kV bus is limited by thermal overloading of the 500/230 kV transformers under Category P1 conditions as shown in Table F.13-13. The constraint was observed under both the HSN and SSN scenarios. Table F.13-14 shows the amount of generation that would be undeliverable without mitigation. The constraint can be mitigated by the existing West of Colorado River CRAS.

*Table F.13-13: Red Bluff 500/230 kV 2040 on-peak deliverability constraint*

Overloaded Facility	Contingency	Base Portfolio Loading (%)	
		HSN	SSN
Red Bluff 500/230 kV Transformer No.1	Red Bluff 500/230 kV Transformer No.2	130	137
Red Bluff 500/230 kV Transformer No.2	Red Bluff 500/230 kV Transformer No.1	130	137

Table F.13-14: Red Bluff 500/230 kV 2040 on-peak constraint summary

Affected transmission zones		Red Bluff 230 kV	
		HSN	SSN
Portfolio resources behind the constraint (Installed FCDS capacity)		961 MW	
Generic portfolio battery storage behind the constraint (Installed FCDS capacity)		0 MW	
Deliverable portfolio resources w/o mitigation (Installed FCDS capacity)		551 MW	0 MW
Total undeliverable baseline and portfolio resources (Installed FCDS capacity)		410 MW	1082 MW
Mitigation Options	RAS	Existing West of Colorado River CRAS	
	Reduce generic battery storage (MW)	Not needed	
	Grid Enhancing Technology	Not needed	
	Transmission upgrade including cost	Not needed	
Recommended Mitigation		Existing West of Colorado River CRAS	

Affected interties	N/A
MIC expansion request MW behind constraint	N/A
Deliverable MIC expansion request MW	N/A

### Devers-Red Bluff Constraint

The deliverability of full capacity resources in the SCE Eastern and SDG&E areas is limited by thermal overloading of the Devers-Red Bluff 500 kV lines under Category P1 conditions as shown in Table F.13-15. The constraint was observed under both the HSN and SSN scenarios. Furthermore, the PALOVRDE\_ITC (PVWEST) MIC expansion request is behind this constraint, and the expansion request is undeliverable. Table F.13-16 shows the amount of generation that would be undeliverable without mitigation.

For both the HSN and SSN scenarios, the existing West of Colorado River CRAS alone is not sufficient to mitigate the constraint in 2040 since the amount of generation tripping needed exceeds the 1150 MW limit for a P1 contingency. Reducing generic battery storage is also not considered to be a sufficient solution. A transmission upgrade, such as building another Devers-Red Bluff 500 kV transmission line, was considered to fully mitigate the constraint.

Further studies are needed in future planning cycle(s) to determine if a new Devers-Red Bluff 500 kV transmission line is the most effective solution considering technical and cost impacts. The ISO will continue to monitor the need for this upgrade in future studies and re-evaluate the mitigation options if needed.

Table F.13-15: Devers-Red Bluff 2040 on-peak deliverability constraint

Overloaded Facility	Contingency	Base Portfolio Loading (%)	
		HSN	SSN
Devers – Red Bluff 500 kV No.1	Devers – Red Bluff 500 kV No.2	111	109
Devers – Red Bluff 500 kV No.2	Devers – Red Bluff 500 kV No.1	111	109

Table F.13-16: Devers-Red Bluff 2040 on-peak constraint summary

Affected transmission zones		SCE Eastern (east of Red Bluff) and SDG&E	
		HSN	SSN
Portfolio resources behind the constraint (Installed FCDS capacity)		6690 MW	
Generic portfolio battery storage behind the constraint (Installed FCDS capacity)		749 MW	
Deliverable portfolio resources w/o mitigation (Installed FCDS capacity)		4748 MW	5076 MW
Total undeliverable baseline and portfolio resources (Installed FCDS capacity)		1942 MW	1614 MW
Mitigation Options	RAS	Existing West of Colorado River CRAS alone not sufficient	
	Reduce generic battery storage (MW)	Not sufficient	
	Grid Enhancing Technology	To be further evaluated in future planning cycle(s)	
	Transmission upgrade including cost	New Devers-Red Bluff 500 kV transmission line (\$875M)	
Recommended Mitigation		Mitigation options to be further evaluated in future planning cycle(s)	

Affected inerties	PALOVRDE_ITC (PVWEST)
MIC expansion request MW behind constraint	551 nameplate wind
Deliverable MIC expansion request MW	0

Serrano-Alberhill-Valley Constraint

The deliverability of full capacity resources in the SCE Eastern and SDG&E areas is limited by thermal overloading of the Devers 500/230 kV transformers as shown in Table F.13-18. The constraint was only observed under the HSN scenario. Furthermore, the PALOVRDE\_ITC (PVWEST) MIC expansion request is behind this constraint, and the expansion request is undeliverable in the HSN scenario. Table F.13-19 shows the amount of generation that would be undeliverable without mitigation.

Based on the RAS guidelines (ISO G-RAS2) stated in the California ISO Planning Standards<sup>16</sup>, the existing Inland Devers Extension CRAS cannot be expanded to monitor overloads on Devers transformers. Reducing generic battery storage and using grid enhancing technologies are also not considered to be viable solutions. To fully mitigate this constraint, a transmission upgrade such as installing another 500/230 kV transformer at Devers was considered. However, since the need for this upgrade wasn't identified in the 2035 base portfolio and the time to construct is expected to be nine years or less, the upgrade is not recommended at this time. The ISO will continue to monitor this constraint in future planning cycle(s) and re-evaluate the mitigation options if needed.

*Table F.13-17: Serrano-Alberhill-Valley 2040 on-peak deliverability constraint*

Overloaded Facility	Contingency	Base Portfolio Loading (%)	
		HSN	SSN
Devers 500/230 kV Transformer No. 1	Serrano-Alberhill-Valley 500 kV No.1	103	<100
Devers 500/230 kV Transformer No. 2		101	<100

*Table F.13-18: Serrano-Alberhill-Valley 2040 on-peak constraint summary*

Affected transmission zones	SCE Eastern, SDG&E	
	HSN	SSN
Portfolio resources behind the constraint (Installed FCDS capacity)	8433 MW	N/A
Generic portfolio battery storage behind the constraint (Installed FCDS capacity)	749 MW	
Deliverable portfolio resources w/o mitigation (Installed FCDS capacity)	7507 MW	

<sup>16</sup> <https://www.caiso.com/Documents/ISO-Planning-Standards-Effective-Feb22023.pdf>

Total undeliverable baseline and portfolio resources (Installed FCDS capacity)		926 MW	
Mitigation Options	RAS	Inland Devers Extension CRAS cannot be expanded to monitor overloads on Devers transformers.	
	Reduce generic battery storage (MW)	Not sufficient	
	Grid Enhancing Technology	Not applicable	
	Transmission upgrade including cost	New Devers No.3 500/230 kV transformer (\$141–\$193 million)	
Recommended Mitigation		Mitigation options to be further evaluated in future planning cycle(s)	

Affected interties	PALOVRDE_ITC (PVWEST)
MIC expansion request MW behind constraint	551 nameplate wind
Deliverable MIC expansion request MW	0

### Blythe Constraint

The deliverability of full capacity resources in the Blythe area is limited by thermal overloading of the Blythe SCE-WAPA 161 kV tie-line as shown in Table F.13-20. The constraint was observed under both the HSN and SSN scenarios. This constraint is driven by the BLYTHE\_ITC MIC, which is undeliverable in 2040, and rapid load growth in the Blythe area. It is also potentially attributed to loop flow issues from neighboring jurisdictions. Table F.13-21 shows the amount of generation that would be undeliverable without mitigation.

RAS and reducing generic battery storage are not applicable solutions as it wouldn't meet the ISO RAS guidelines and there is no generic storage in the area. Upgrading the rating of the tie-line was considered, however, this option would require a WECC path rating study

given that the line is WECC Path 59. Furthermore, low-voltage issues in the Blythe area were identified in the reliability studies for this planning cycle as load is projected to rapidly grow in the region. SCE is currently conducting a method of service study to address these issues. Once the preferred method of service is identified, SCE will be seeking ISO approval on the proposed network upgrades.

No transmission upgrade to address deliverability issues is recommended at this time. The ISO will continue to monitor this constraint in future planning cycle(s) and re-evaluate the mitigation options in coordination with the results of SCE’s method of service study.

Table F.13-19: Blythe 2040 on-peak deliverability constraint

Overloaded Facility	Contingency	Base Portfolio Loading (%)	
		HSN	SSN
Blythe SCE-WAPA 161 kV Tie-line	Julian Hinds 220 kV Bus Section (SCE-MWD)	180	180
	Julian Hinds-Eagle Mountain 220 kV	172	171
	Buck Blvd-Julian Hinds 220 kV	172	185
	Imperial Valley-North of SONGS 500 kV	152	164
	Devers – Red Bluff 500 kV No.2	149	161
	Devers – Red Bluff 500 kV No.1	149	161
	Base Case	145	156

Table F.13-20: Blythe 2040 on-peak constraint summary

Affected transmission zones	Blythe 161 kV	
	HSN	SSN
Portfolio resources behind the constraint (Installed FCDS capacity)	145 MW	
Generic portfolio battery storage behind the constraint (Installed FCDS capacity)	0 MW	
Deliverable portfolio resources w/o mitigation (Installed FCDS capacity)	0 MW	0 MW

Total undeliverable baseline and portfolio resources (Installed FCDS capacity)		145 MW	145 MW
Mitigation Options	RAS	Not compliant with the ISO RAS guidelines	
	Reduce generic battery storage (MW)	Not applicable	
	Grid Enhancing Technology	To be further evaluated in future planning cycle(s)	
	Transmission upgrade including cost	<ol style="list-style-type: none"> <li>Upgrade line rating of the Blythe SCE-WAPA Tie-line</li> <li>Network upgrades identified as part of SCE's ongoing method of service study to address low-voltage issues in the Blythe area as load is projected to grow rapidly in the Blythe area</li> </ol>	
Recommended Mitigation		Mitigation options to be further evaluated in future planning cycle(s), aligning with the results of SCE's Method of Service study	

Affected interties	BLYTHE_ITC
MIC expansion request MW behind constraint	145
Deliverable MIC expansion request MW	0

### F.13.3. 2040 Off-peak results

#### Colorado River 500/230 kV Constraint

Wind and solar resources interconnecting at the Colorado River 230 kV bus are subject to curtailment in the base portfolio due to loading limitations on the transformers under Category P1 conditions, as shown in Table F.13-22. Utilizing the existing West of Colorado River CRAS and dispatching battery storage in charging mode are not sufficient to fully mitigate the off-peak constraint. A transmission upgrade such as installing another 500/230 kV transformer at Colorado River was considered.

No transmission upgrade is recommended in this planning cycle for this off-peak constraint since no congestion on the transformers at the Colorado River substation were observed in this cycle’s economic studies. The ISO will continue to monitor the need for

this upgrade in future studies and re-evaluate the mitigation options if needed. Any mitigation proposed for the on-peak Colorado River 500/230 kV constraint is also expected to mitigate the off-peak constraints.

Table F.13-21: Colorado River 500/230 kV 2040 off-peak deliverability constraint

Overloaded Facility	Contingency	Loading (%)
Colorado River 500/230 kV Transformer No.1	Colorado River 500/230 kV Transformer No.2	195
	Base Case	118
Colorado River 500/230 kV Transformer No.2	Colorado River 500/230 kV Transformer No.1	195
	Base Case	114

Table F.13-22: Colorado River 500/230 kV 2040 off-peak constraint summary

Affected renewable transmission zones		Colorado River 230 kV
Portfolio solar and wind resources behind the constraint		881 MW
Portfolio energy storage behind the constraint		484 MW
Renewable curtailment without mitigation		1709 MW
Mitigation Options:	Portfolio ES (in charging mode) <sup>17</sup>	Not sufficient
	RAS	Existing West of Colorado River CRAS not sufficient
	Grid Enhancing Technology	Not applicable
	Transmission upgrades	New Colorado River No.3 500/230 kV transformer (\$67M)
Recommended Mitigation		See SCE Eastern area on-peak deliverability constraint mitigation

### Red Bluff 500/230 kV Constraint

Wind and solar resources interconnecting at the Red Bluff 230 kV bus are subject to curtailment in the base portfolio due to loading limitations on the transformers under Category P1 conditions, as shown in Table F.13-24. Pre-contingency curtailment can be avoided by dispatching battery storage in charging mode and/or utilizing the existing West of Colorado River CRAS.

<sup>17</sup> The Portfolio energy storage (in charging mode) amount is the amount needed to mitigate the constraint after baseline battery storage is fully utilized.

Table F.13-23: Red Bluff 500/230 kV 2040 off-peak deliverability constraint

Overloaded Facility	Contingency	Loading (%)
Red Bluff 500/230 kV Transformer No.1	Red Bluff 500/230 kV Transformer No.2	123
Red Bluff 500/230 kV Transformer No.2	Red Bluff 500/230 kV Transformer No.1	123

Table F.13-24: Red Bluff 500/230 kV 2040 off-peak constraint summary

Affected renewable transmission zones		Red Bluff 230 kV
Portfolio solar and wind resources behind the constraint		78 MW
Portfolio energy storage behind the constraint		922 MW
Renewable curtailment without mitigation		456 MW
Mitigation Options:	Portfolio ES (in charging mode) <sup>18</sup>	330 MW
	RAS	Existing West of Colorado River CRAS
	Grid Enhancing Technology	Not needed
	Transmission upgrades	Not needed
Recommended Mitigation		Existing West of Colorado River CRAS and/or battery storage in charging mode

### Devers-Red Bluff Constraint

Wind and solar resources in the SCE Eastern and SDG&E areas are subject to curtailment in the base portfolio due to loading limitations on the Devers-Red Bluff 500 kV lines under Category P1 conditions, as shown in Table F.13-26. Pre-contingency curtailment can be avoided by dispatching battery storage in charging mode and/or utilizing the existing West of Colorado River CRAS.

Table F.13-25: Devers-Red Bluff 2040 off-peak deliverability constraint

Overloaded Facility	Contingency	Loading (%)
Devers – Red Bluff 500 kV No.1	Devers – Red Bluff 500 kV No.2	104
Devers – Red Bluff 500 kV No.2	Devers – Red Bluff 500 kV No.1	104

<sup>18</sup> The Portfolio energy storage (in charging mode) amount is the amount needed to mitigate the constraint after baseline battery storage is fully utilized.

Table F.13-26: Devers-Red Bluff 2040 off-peak constraint summary

Affected renewable transmission zones		SCE Eastern (east of Red Bluff) and SDG&E
Portfolio solar and wind resources behind the constraint		3159 MW
Portfolio energy storage behind the constraint		5054 MW
Renewable curtailment without mitigation		2076 MW
Mitigation Options:	Portfolio ES (in charging mode) <sup>19</sup>	1290 MW
	RAS	Existing West of Colorado River CRAS
	Grid Enhancing Technology	Not needed
	Transmission upgrades	Not needed
Recommended Mitigation		Existing West of Colorado River CRAS and/or battery storage in charging mode

### Blythe Constraint

Resources interconnecting in the Blythe area are subject to curtailment in the base portfolio due to loading limitations on the Blythe SCE-WAPA 161 kV tie-line as shown in Table F.13-28.

RAS and dispatching battery storage in charging mode are not applicable solutions as it wouldn't meet the ISO RAS guidelines and there is no generic storage in the area. Upgrading the rating of the tie-line was considered, however, this option would require a WECC path rating study given that the line is WECC Path 59. Furthermore, low-voltage issues in the Blythe area were identified in the reliability studies for this planning cycle as load is projected to rapidly grow in the region. SCE is currently conducting a method of service study to address these issues. Once the preferred method of service is identified, SCE will be seeking ISO approval on the proposed network upgrades.

No transmission upgrade to address off-peak deliverability issues is recommended at this time. The ISO will continue to monitor this constraint in future planning cycle(s) and re-evaluate the mitigation options in coordination with the results of SCE's method of service study.

<sup>19</sup> The Portfolio energy storage (in charging mode) amount is the amount needed to mitigate the constraint after baseline battery storage is fully utilized.

Table F.13-27: Blythe 2040 off-peak deliverability constraint

Overloaded Facility	Contingency	Loading (%)
Blythe SCE-WAPA 161 kV Tie-line	Julian Hinds 220 kV Bus Section (SCE-MWD)	103
	Imperial Valley-North of SONGS 500 kV	101

Table F.13-28: Blythe 2040 off-peak constraint summary

Affected renewable transmission zones		Blythe 161 kV
Portfolio solar and wind resources behind the constraint		0 MW
Portfolio energy storage behind the constraint		0 MW
Renewable curtailment without mitigation		42 MW
Mitigation Options:	Portfolio ES (in charging mode) <sup>20</sup>	Not applicable
	RAS	Not compliant with the ISO RAS guidelines
	Grid Enhancing Technology	To be further evaluated in future planning cycle(s)
	Transmission upgrades	1. Upgrade line rating of the Blythe SCE-WAPA Tie-line 2. Network upgrades identified as part of SCE's ongoing method of service study to address low-voltage issues in the Blythe area as load is projected to rapidly grow in the region
Recommended Mitigation		Mitigation options to be further evaluated in future planning cycle(s), aligning with the results of SCE's Method of Service study

### F.13.4. Conclusion and recommendation

The SCE Eastern area base and sensitivity portfolios deliverability assessment for 2035 and 2040 identified on-peak and off-peak deliverability constraints. The West of Colorado River CRAS can be used to mitigate several of these constraints. Some off-peak constraints can also be mitigated by dispatching battery storage in charging mode.

<sup>20</sup> The Portfolio energy storage (in charging mode) amount is the amount needed to mitigate the constraint after baseline battery storage is fully utilized.

Transmission upgrades were also considered in this planning cycle; however, they are not recommended for approval at this time. The ISO will continue to monitor the need for these upgrades in future studies.

- New Colorado River No.3 500/230 kV transformer
- New Devers-Red Bluff 500 kV transmission line
- New Devers No.3 500/230 kV transformer

For the Blythe area, reliability issues were identified in this planning cycle. SCE is currently conducting a method of service study to address low-voltage issues in the Blythe area as load is projected to rapidly grow in the region. Once the preferred method of service is identified, SCE will be seeking ISO approval on the proposed network upgrades. Mitigation options to address deliverability constraints in the Blythe area will be coordinated with the results of SCE's method of service study.

## F.14. SCE Metro Area

The total capacity of resources, by resource type, selected with Full Capacity Deliverability Status (FCDS) as well as those selected as Energy Only (EO) in the SCE Metro interconnection area, are listed in Table F.14-1. The portfolios in the interconnection area are comprised of battery storage and biomass/biogas resources. All portfolio resources are modeled in policy-driven assessments except in the on-peak deliverability assessment in which only FCDS resources are modeled.

*Table F.14-1: SCE Metro Interconnection Area – Base and Sensitivity Portfolios by Resource Types (FCDS, EO and Total)*

Resource Type	2035 Base Portfolio			2040 Base Portfolio			2035 Sensitivity Portfolio		
	FCDS (MW)	EO (MW)	Total (MW)	FCDS (MW)	EO (MW)	Total (MW)	FCDS (MW)	EO (MW)	Total (MW)
Solar	0	0	0	0	0	0	0	0	0
Wind – In State	0	0	0	0	0	0	0	0	0
Wind – Out-of-State	1,750	0	1,750	1,750	0	1,750	0	0	0
Wind - Offshore	0	0	0	0	0	0	0	0	0
Li Battery – 4 hr	2,856	0	2,856	2,856	0	2,856	2,826	0	2,826
Li Battery – 8 hr	223	0	223	644	0	644	223	0	223
Long Duration Energy Storage (LDES)	0	0	0	0	0	0	0	0	0
Geothermal	389	0	389	389	0	389	389	0	389
Biomass/Biogas	0	0	0	0	0	0	0	0	0
Distributed Solar	0	23	23	0	23	23	0	23	23
<b>Total</b>	<b>5,218</b>	<b>23</b>	<b>5,231</b>	<b>5,629</b>	<b>23</b>	<b>5,662</b>	<b>3,438</b>	<b>23</b>	<b>3,461</b>

Figure F.13-1: SCE Metro Interconnection Area – 2035 Base Portfolio

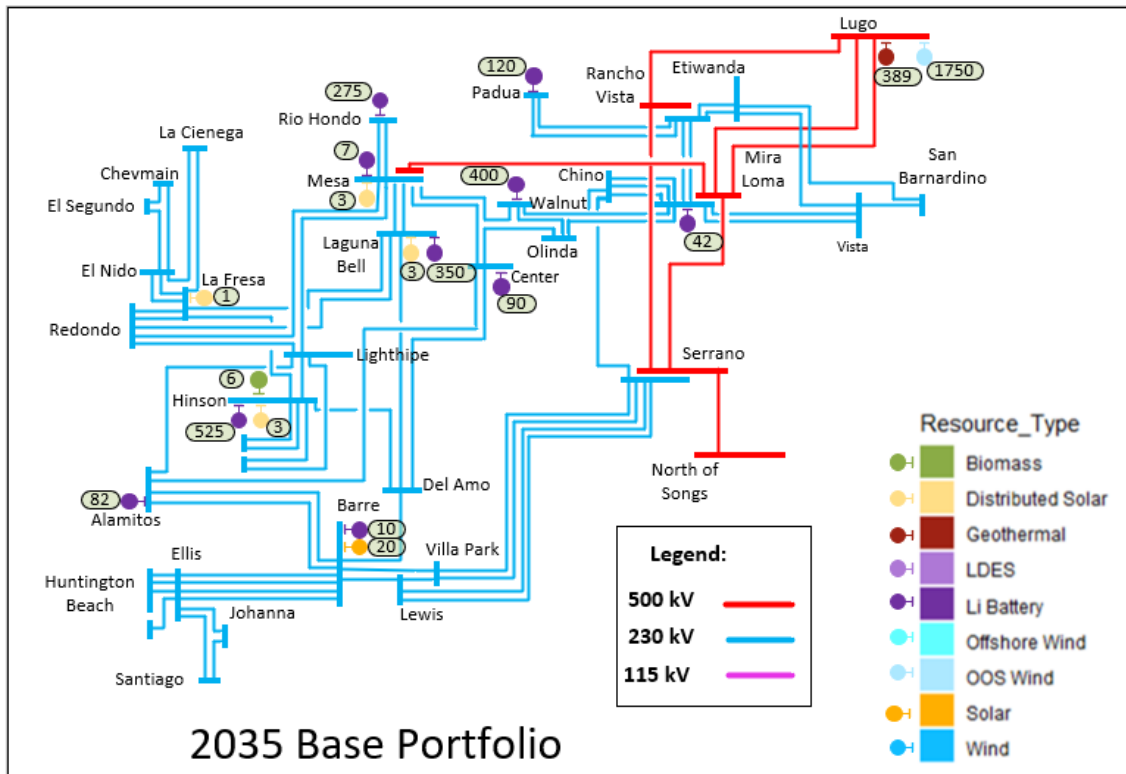

Figure F.13-2: SCE Metro Interconnection Area – 2040 Base Portfolio

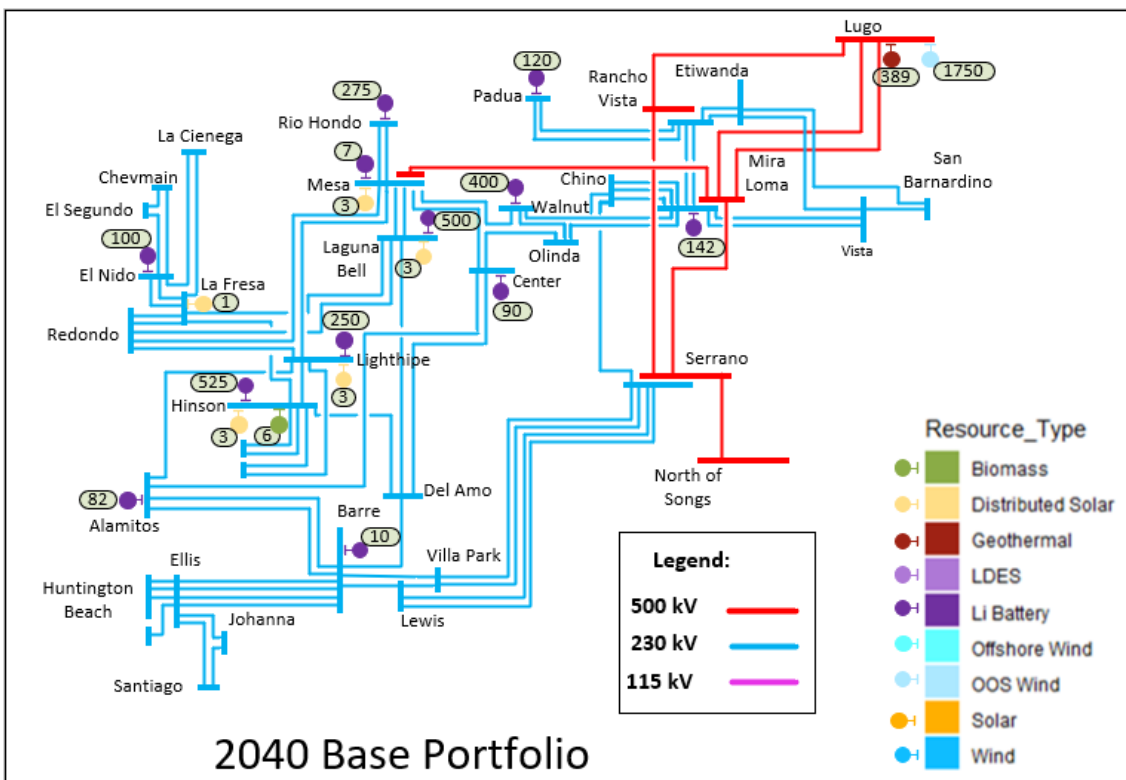
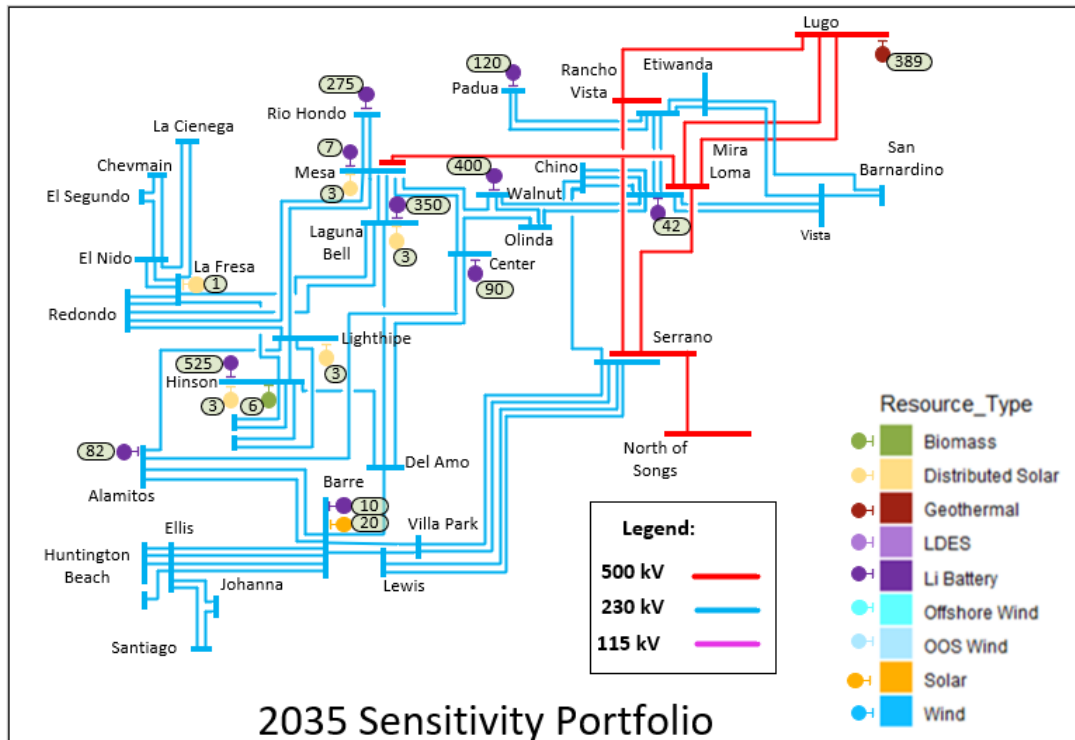

Figure F.13-3: SCE Metro Interconnection Area – 2035 Sensitivity Portfolio



### F.14.1. 2035 On-peak results

The SCE Metro area deliverability assessment did not identify any base portfolio 2035 on-peak deliverability constraints that require transmission upgrades.

### F.14.2. 2040 On-peak results

The SCE Metro area deliverability assessment did not identify any base portfolio 2040 on-peak deliverability constraints that require transmission upgrades.

### F.14.3. 2040 Off-peak results

The SCE Metro area deliverability assessment did not identify any base portfolio 2040 off-peak deliverability constraints that require transmission upgrades.

#### F.14.4. Conclusion and recommendation

No deliverability constraints were identified, except for the 2040 Peak SSN case.

A transmission upgrade identified as needed under the secondary system need scenario analysis will go through a comprehensive economic, policy, and reliability benefit analysis to determine if the upgrade would provide sufficient benefits to be considered for a recommendation of approval as a policy driven or economic upgrade. The transmission planning process could make a determination that an upgrade is not needed for the identified secondary system need deliverability constraint.

Due to the significant increase in BESS resources within the area, the previously proposed Del Amo 500kV facilities, considered in the 2022–2023 TPP policy study, are no longer needed as a policy-driven transmission upgrade in the HSN cases.

## F.15. SDG&E area

The total capacity of resources, by resource type, selected with Full Capacity Deliverability Status (FCDS) as well as those selected as Energy Only (EO) in the SDG&E interconnection area are listed in Table F.15-1. The portfolios in the interconnection area are comprised of solar, wind, battery storage and geothermal resources. All portfolio resources are modeled in policy-driven assessments except in the on-peak deliverability assessment in which only FCDS resources are modeled.

*Table F.15-1: SDG&E Interconnection Area – Base and Sensitivity Portfolios by Resource Types (FCDS, EO and Total)*

Resource Type	2035 Base Portfolio			2040 Base Portfolio			2035 Sensitivity Portfolio		
	FCDS (MW)	EO (MW)	Total (MW)	FCDS (MW)	EO (MW)	Total (MW)	FCDS (MW)	EO (MW)	Total (MW)
Solar	1,100	601	1,700	1,238	1,762	3,000	1,100	578	1,678
Wind – In State	1,271	556	1,827	1,271	556	1,827	1,271	556	1,827
Wind – Out-of-State	0	0	0	0	0	0	0	0	0
Wind - Offshore	0	0	0	0	0	0	0	0	0
Li Battery – 4 hr	2,157	0	2,157	2,102	0	2,102	2,130	0	2,130
Li Battery – 8 hr	151	0	151	845	0	845	101	0	101
Long Duration Energy Storage (LDES)	409	0	409	409	0	409	409	0	409
Geothermal	100	0	100	100	0	100	140	0	140
Biomass/Biogas	0	0	0	0	0	0	0	0	0
Distributed Solar	0	14	14	0	14	14	0	0	0
<b>Total</b>	<b>5,188</b>	<b>1,171</b>	<b>6,358</b>	<b>5,965</b>	<b>2,332</b>	<b>8,297</b>	<b>5,151</b>	<b>1,134</b>	<b>6,285</b>

The resources as identified in the CPUC busbar mapping for the SDG&E interconnection area are illustrated on the single-line diagrams below.



Figure F.15-2: SDG&E Interconnection Area – Mapped 2040 Base Portfolio

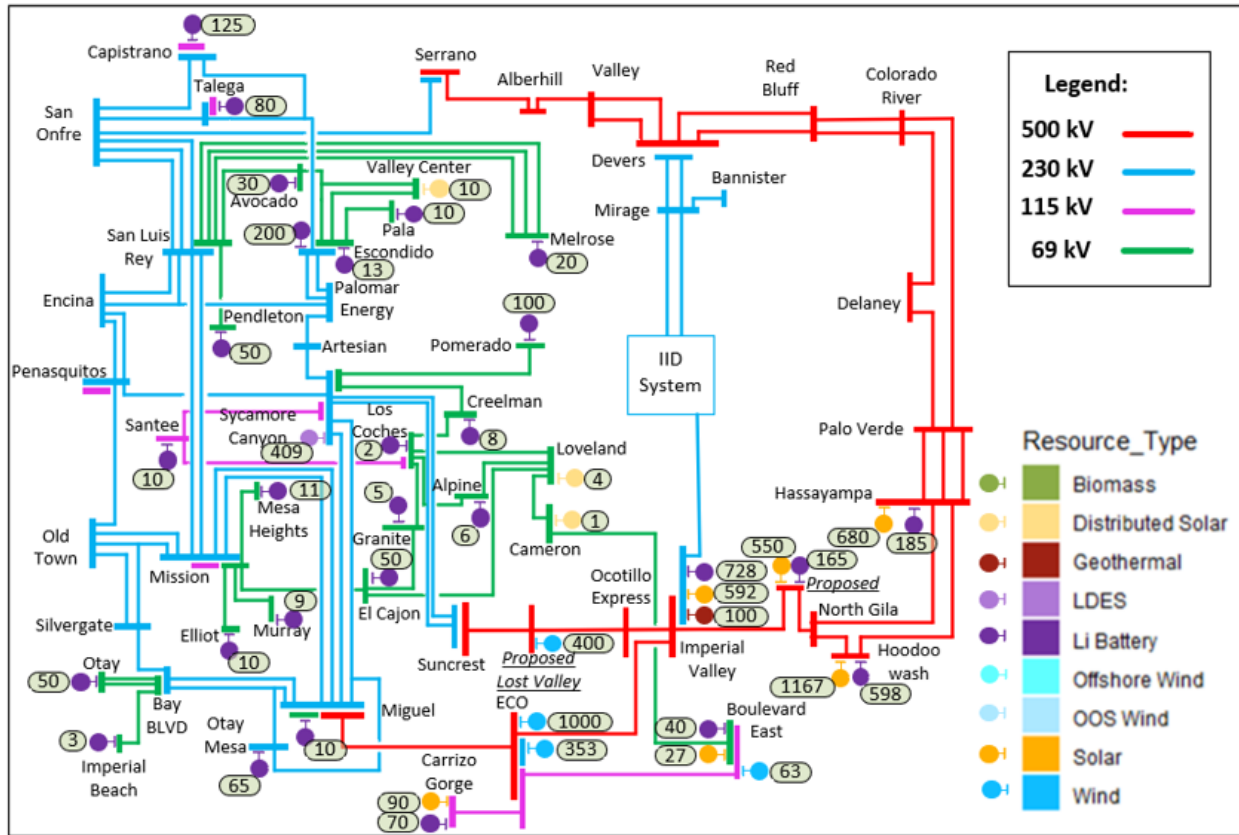
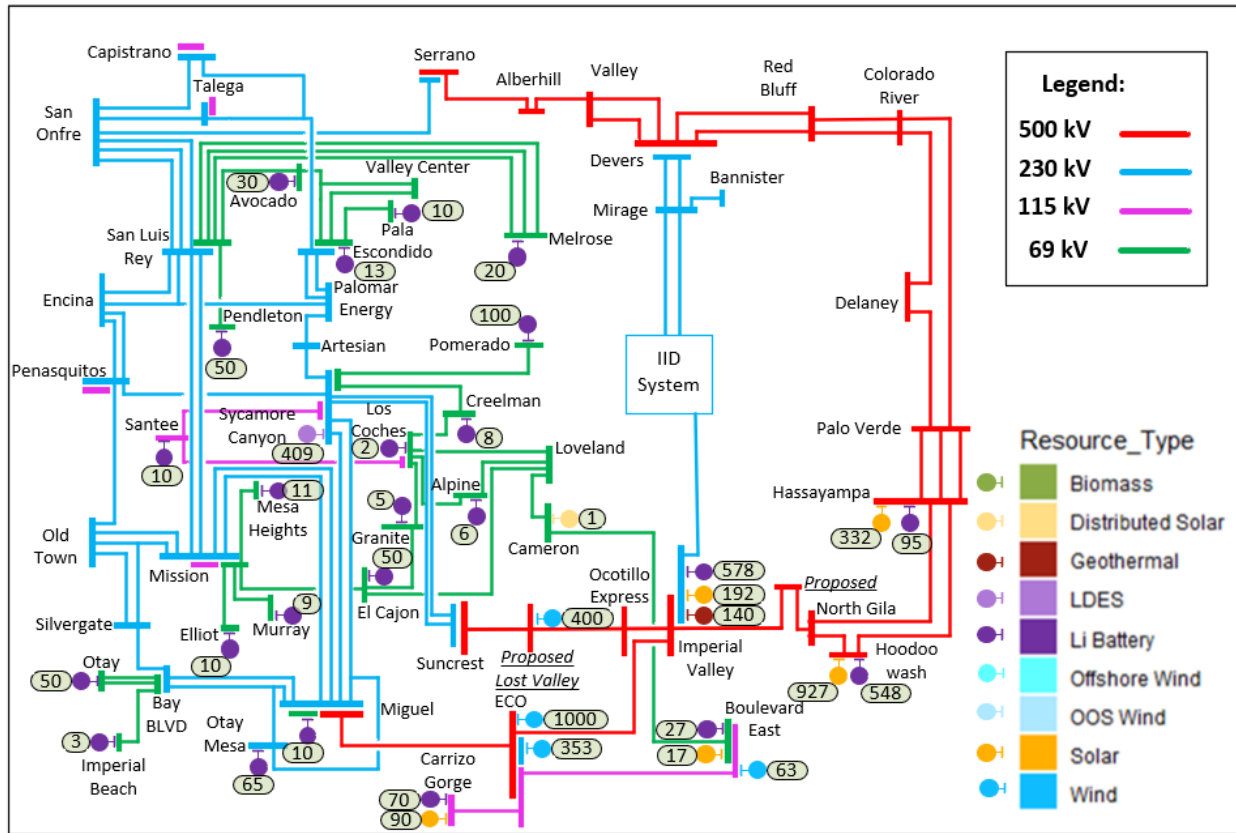

Figure F.15-3: SDG&E Interconnection Area – Mapped 2035 Sensitivity Portfolio



### F.15.1. 2035 On-peak results

#### Sycamore-Scripps constraint

The deliverability of portfolio resources in the Sycamore-Scripps area is limited by thermal overloading of the Sycamore-Scripps 69 kV line as shown in Table F.15-2. The constraint was seen in the 2035 Base and Sensitivity scenarios. Table F.15-3 shows the amount of portfolio generation that would be deliverable without any transmission upgrades.

The constraint can be mitigated by using the 30 minute emergency rating of the Sycamore-Scripps 69 kV line.

Table F.15-2: Sycamore-Scripps 2035 on-peak deliverability constraint

Overloaded Facility	Contingency	Loading (%)	
		Base	Sensitivity
Sycamore-Scripps 69 kV	Sycamore-Penasquitos 230 kV	107	107

Table F.15-3: Sycamore-Scripps 2035 on-peak constraint summary

Affected transmission zones		SDGE Internal	
		Base	Sensitivity
Portfolio resources behind the constraint (Installed FCDS capacity)		511	511
Generic portfolio battery storage behind the constraint (Installed FCDS capacity)		0	0
Deliverable portfolio resources w/o mitigation (Installed FCDS capacity)		409	400
Total undeliverable baseline and portfolio resources (Installed FCDS capacity)		102	111
Mitigation Options	RAS	Not applicable	
	Reduce generic battery storage (MW)	Not applicable	
	Grid Enhancing Technology	Not applicable	
	Transmission upgrade including cost	Use 30 minute rating	
Recommended Mitigation		Use 30 minute rating	

Affected interties	Not applicable
MIC expansion request MW behind constraint	Not applicable
Deliverable MIC expansion request MW	Not applicable

### F.15.2. 2040 On-peak results

#### Sycamore-Scripps constraint

The deliverability of portfolio resources in the Sycamore-Scripps area is limited by thermal overloading of the Sycamore-Scripps 69 kV line as shown in Table F.15-4. The constraint was seen in the 2040 Base scenario. Table F.15-5 shows the amount of portfolio generation that would be deliverable without any transmission upgrades.

The constraint can be mitigated by using the 30 minute emergency rating of the Sycamore-Scripps 69 kV line.

Table F.15-4: Sycamore-Scripps 2040 on-peak deliverability constraint

Overloaded Facility	Contingency	Loading (%)	
		HSN	SSN
Sycamore-Scripps 69 kV	Sycamore-Penasquitos 230 kV	118	108
	Miramar GT-Miramar 69 kV	107	100
	Penasquitos 230/69 kV #2	106	100

Table F.15-5: Sycamore-Scripps 2040 on-peak constraint summary

Affected transmission zones		SDGE Internal	
		HSN	SSN
Portfolio resources behind the constraint (Installed FCDS capacity)		511	
Generic portfolio battery storage behind the constraint (Installed FCDS capacity)		0	
Deliverable portfolio resources w/o mitigation (Installed FCDS capacity)		0	Not applicable
Total undeliverable baseline and portfolio resources (Installed FCDS capacity)		511	
Mitigation Options	RAS	Not applicable	
	Reduce generic battery storage (MW)	Not applicable	
	Grid Enhancing Technology	Not applicable	
	Transmission upgrade including cost	Use 30 minute emergency rating	
Recommended Mitigation		Use 30 minute emergency rating	

Affected interties	Not applicable
MIC expansion request MW behind constraint	Not applicable
Deliverable MIC expansion request MW	Not applicable

### Escondido-San Marcos constraint

The deliverability of portfolio resources in the Escondido-San Marcos area is limited by thermal overloading of the Escondido-San Marcos 69 kV line as shown in Table F.15-6. The constraint was seen in the 2040 Base scenario. Table F.15-7 shows the amount of portfolio generation that would be deliverable without any transmission upgrades.

The constraint can be mitigated by using the existing CEC RAS (230kV TL 23003 Encina-San Luis Rey/ TL 23011 Encina-San Luis Rey-Palomar RAS).

Table F.15-6: Escondido-San Marcos 2040 on-peak deliverability constraint

Overloaded Facility	Contingency	Loading (%)	
		HSN	SSN
Escondido-San Marcos 69 kV	San Luis Rey-Encina 230 kV and San Luis Rey-Encina-Palomar 230 kV	102	<100

Table F.15-7: Escondido-San Marcos 2040 on-peak constraint summary

Affected transmission zones		SDGE Internal	
		HSN	SSN
Portfolio resources behind the constraint (Installed FCDS capacity)		678	
Generic portfolio battery storage behind the constraint (Installed FCDS capacity)		268	
Deliverable portfolio resources w/o mitigation (Installed FCDS capacity)		600	Not applicable
Total undeliverable baseline and portfolio resources (Installed FCDS capacity)		78	
Mitigation Options	RAS	Existing CEC RAS (230kV TL 23003 Encina-San Luis Rey/ TL 23011 Encina-San Luis Rey-Palomar RAS)	
	Reduce generic battery storage (MW)	Not applicable	
	Grid Enhancing Technology	Not applicable	
	Transmission upgrade including cost	Not applicable	
Recommended Mitigation		Existing CEC RAS (230kV TL 23003 Encina-San Luis Rey/ TL 23011 Encina-San Luis Rey-Palomar RAS)	

Affected interties	Not applicable
MIC expansion request MW behind constraint	Not applicable
Deliverable MIC expansion request MW	Not applicable

Silvergate-Old Town constraint

The deliverability of portfolio resources in the Silvergate-Old Town area is limited by thermal overloading of the Silvergate-Old Town 230 kV lines as shown in Table F.15-8. The constraint was seen in the 2040 Base scenario. Table F.15-9 shows the amount of portfolio generation that would be deliverable without any transmission upgrades.

The constraint can be mitigated by using the using the 30 minute emergency rating of the overloaded lines.

*Table F.15-8: Silvergate-Old Town 2040 on-peak deliverability constraint*

Overloaded Facility	Contingency	Loading (%)	
		HSN	SSN
Silvergate-Vine 230 kV	Silvergate-Mission-Old Town 230 kV	106	<100
	Old Town-Mission 230 kV and Silvergate-Mission-Old Town 230 kV	112	<100
Silvergate-Old Town Tap 230 kV	Silvergate-Vine 230 kV	100	<100

*Table F.15-9: Silvergate-Old Town 2040 on-peak constraint summary*

Affected transmission zones		Imperial Valley, ECO/BUE, SDGE Internal	
		HSN	SSN
Portfolio resources behind the constraint (Installed FCDS capacity)		727	
Generic portfolio battery storage behind the constraint (Installed FCDS capacity)		54	
Deliverable portfolio resources w/o mitigation (Installed FCDS capacity)		453	Not applicable
Total undeliverable baseline and portfolio resources (Installed FCDS capacity)		274	
Mitigation Options	RAS	Not applicable	
	Reduce generic battery storage (MW)	Not applicable	
	Grid Enhancing Technology	Not applicable	
	Transmission upgrade including cost	Use 30 minute emergency rating	
Recommended Mitigation		Use 30 minute emergency rating	

Affected interties	Not applicable
MIC expansion request MW behind constraint	Not applicable
Deliverable MIC expansion request MW	Not applicable

Bay Boulevard-Silvergate constraint

The deliverability of portfolio resources in the Bay Boulevard-Silvergate area is limited by thermal overloading of the Bay Boulevard-Silvergate 230 kV line as shown in Table F.15-10. The constraint was seen in the 2040 Base scenario. Table F.15-11 shows the amount of portfolio generation that would be deliverable without any transmission upgrades.

The constraint can be mitigated by using the using the 2-hour emergency rating of the overloaded line.

*Table F.15-10: Bay Boulevard-Silvergate 2040 on-peak deliverability constraint*

Overloaded Facility	Contingency	Loading (%)	
		HSN	SSN
Bay Boulevard-Silvergate 230 kV	Miguel-Mission 230 kV #1 and #2	101	100

*Table F.15-11: Bay Boulevard-Silvergate 2040 on-peak constraint summary*

Affected transmission zones		Imperial Valley, ECO/BUE, SDGE Internal	
		HSN	SSN
Portfolio resources behind the constraint (Installed FCDS capacity)		1856	
Generic portfolio battery storage behind the constraint (Installed FCDS capacity)		158	
Deliverable portfolio resources w/o mitigation (Installed FCDS capacity)		1340	Not applicable
Total undeliverable baseline and portfolio resources (Installed FCDS capacity)		516	
Mitigation Options	RAS	Not applicable	
	Reduce generic battery storage (MW)	Not applicable	
	Grid Enhancing Technology	Not applicable	
	Transmission upgrade including cost	Use 2-hour emergency rating	
Recommended Mitigation		Use 2-hour emergency rating	

Affected interties	Not applicable
MIC expansion request MW behind constraint	Not applicable
Deliverable MIC expansion request MW	Not applicable

Imperial Valley Bank 82 constraint

The deliverability of portfolio resources in the Imperial Valley area is limited by thermal overloading of the Imperial Valley 500/230 kV #3 Bank 82 transformer as shown in Table F.15-12. The constraint was seen in the 2040 Base scenario. Table F.15-13 shows the amount of portfolio generation that would be deliverable without any transmission upgrades.

The Imperial Valley area has an approved transmission upgrade “Short Circuit Mitigation for Imperial Valley 230 kV Circuit Breakers” that proposes to install current limiting reactors in series with the Imperial Valley 230 kV buses. Part of this upgrade is to rearrange 230 kV transmission lines and move TL23043 Imperial Valley – Westside Canal, TL23066, Imperial Valley – Drew, and IID owned S-Line Imperial Valley – Wixom SS to the west buses. This configuration results in an overload on Imperial Valley Bank 82 under the SSN scenario when solar output is high. Several options to mitigate this constraint have been considered in addition to the approved TPP upgrade: Option 1: congestion management at Imperial Valley during SSN conditions; Option 2: modify the scope of the approved TPP project to connect TL23066 IV-Drew to East bus and connect TL23045 and 23045 IV-IV GEN2 to West bus; and Option 3: add Imperial Valley 500/230 kV bank #4. The ISO is recommending Option 2 as the mitigation to the identified constraint.

*Table F.15-12: Imperial Valley Bank 82 2040 on-peak deliverability constraint*

Overloaded Facility	Contingency	Loading (%)	
		HSN	SSN
Imperial Valley 500/230 kV #3 Bank 82	Base Case	<100	111

Table F.15-13: Imperial Valley Bank 82 2040 on-peak constraint summary

Affected transmission zones		Imperial Valley	
		HSN	SSN
Portfolio resources behind the constraint (Installed FCDS capacity)		799	
Generic portfolio battery storage behind the constraint (Installed FCDS capacity)		204	
Deliverable portfolio resources w/o mitigation (Installed FCDS capacity)		Not applicable	292
Total undeliverable baseline and portfolio resources (Installed FCDS capacity)			507
Mitigation Options	RAS	Not applicable	
	Reduce generic battery storage (MW)	Not sufficient	
	Grid Enhancing Technology	Not applicable	
	Transmission upgrade including cost	Approved TPP project “Short Circuit Mitigation for Imperial Valley 230 kV Circuit Breakers” and one of the following options: Option 1: curtail solar generation at Imperial Valley during SSN conditions Option 2: modify scope of the approved TPP project to connect TL23066 IV-Drew to East bus and connect TL23045 and 23045 IV-IV GEN2 to West bus, increase size of CLRs to 20-Ohms and operate them as normally closed Option 3: add Imperial Valley 500/230 kV bank #4	
Recommended Mitigation		Approved TPP project “Short Circuit Mitigation for Imperial Valley 230 kV Circuit Breakers” and: Option 2: modify scope of the approved TPP project to connect TL23066 IV-Drew to East bus and connect TL23045 and 23045 IV-IV GEN2 to West bus, increase size of CLRs to 20-Ohms and operate them as normally closed	

Affected interties	Not applicable
MIC expansion request MW behind constraint	Not applicable
Deliverable MIC expansion request MW	Not applicable

### F.15.3. 2040 Off-peak results

No off-peak constraints were identified for the SDG&E area.

### F.15.4. Conclusion and recommendation

The SDG&E area base and sensitivity portfolios deliverability assessment for 2035 and 2040 identified on peak constraints under the HSN scenario. These constraints can be mitigated by using existing RAS and emergency ratings of the overloaded lines.

The SDG&E base portfolio deliverability assessment for 2040 identified an on peak constraint under the SSN scenario on Imperial Valley Bank 82. At this time, the ISO is recommending to modify scope of the approved TPP project “Short Circuit Mitigation for Imperial Valley 230 kV Circuit Breakers” to connect TL23066 IV-Drew to East bus and connect TL23045 and 23045 IV-IV GEN2 to West bus, and to increase size of CLR’s to 20-Ohms and operate them as normally closed.

The off-peak deliverability assessment did not identify any constraints.

Policy-driven transmission upgrades in the SDG&E area are not found to be needed in this planning cycle.

## F.16. Exploring options for integration of out-of-state wind resources

The resource portfolio for the 2025-2026 TPP has a significant amount of OOS wind on new transmission in both the 2035 and 2040 study years (9,000 MW and 10,707 MW, respectively). There are significant challenges in planning transmission for such significant amounts of OOS wind resources. The potential transmission solutions are likely to be significant and challenging. Moreover, any transmission solution considered would be of an interregional nature and involve close coordination with other western transmission providers. Moreover, networked interregional transmission solutions that are considered would need to ensure mutual benefits for all transmission providers involved including the ISO. Also, apart from what is currently in development such as SWIP-North, TWE, and SunZia, there are no known transmission projects in the development pipeline in the public domain. Due to these challenges, CPUC staff recommended that the ISO conduct additional analysis but defer approving any of the potential transmission lines needed for these resources in the 2025-2026 TPP.

Based on the resource portfolio for the 2025-2026 TPP, from Wyoming, there is an additional 1,500 MW wind mapped to Eldorado 500 kV not utilizing the TransWest Express transmission line in the 2035 and 2040 portfolios, along with 1,707 MW of Wyoming wind mapped to Tesla 500 kV in the 2040 portfolio. For New Mexico, there is 1,750 MW New Mexico wind mapped to Lugo 500 kV in the 2035 and 2040 portfolios.

For integrating OOS wind resources from Wyoming or New Mexico, there could be point-to-point HVDC transmission solution approach that was highlighted in the ISO's most recent 20-year Transmission Outlook,<sup>21</sup> networked transmission solution approach involving other western transmission providers or transmission projects in-development, or a hybrid solution approach involving both HVDC and networked transmission solution.

For integrating Wyoming wind resources, potential transmission solution options, as noted in Figure F.16-1, include:

- HVDC or AC transmission solution options from the Wyoming wind resource area to Northern and Southern California.
- Various networked transmission solution options involving coordination with regional transmission providers such as PacifiCorp (utilizing the Gateway Project); Nevada Energy (utilizing the Greenlink transmission projects or the existing ON line); or engaging with TransCanyon's Cross-Tie transmission project or some feasible and

---

<sup>21</sup> <https://www.caiso.com/documents/2024-20-year-transmission-outlook-jul-31-2024.pdf>

effective combinations of these. Such an approach would likely be similar to the SWIP-North transmission project wherein the ISO would have operational control of entitlements for certain capacity MW amounts on the networked transmission lines consistent with the MW amounts required to meet CPUC resource portfolio requirements.

- A hybrid transmission solution approach involving an HVDC component and an AC networked component; for example, an HVDC transmission line to Northern Nevada and tying this to the ISO system through an AC transmission line.

Figure F.16-1: Potential options to integrate Wyoming wind resources

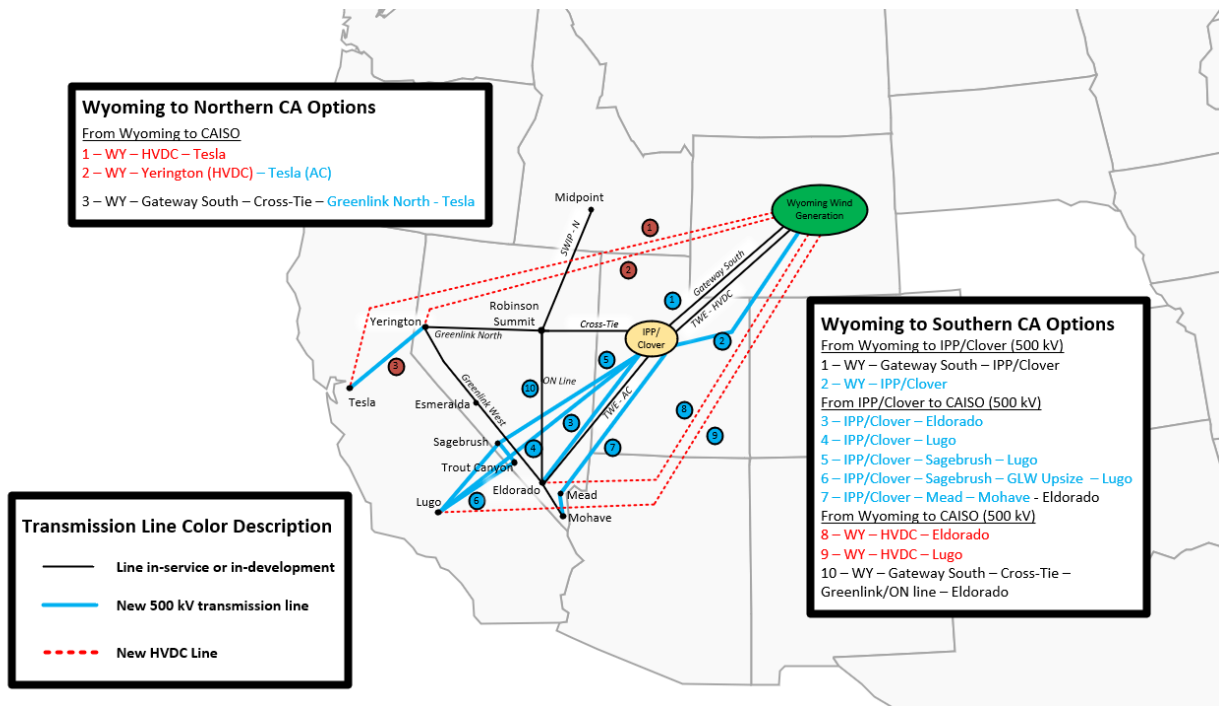

For integrating New Mexico wind resources, potential transmission solution options, as noted in Figure F.16-2, include:

- HVDC or AC transmission solution options from the New Mexico wind resource area to Southern California.
- Various networked transmission solution options involving coordination with regional transmission providers such as the Western Area Power Administration (WAPA), Public Service Company of New Mexico (PNM) or Arizona Public Service (APS). This could also involve a project similar to the in-development RioSol transmission project which would provide benefits to multiple states.<sup>22</sup> Such an approach would likely be similar to

<sup>22</sup> <https://riosol.energy/>

the SWIP-N transmission project wherein the ISO would have operational control of entitlements for certain capacity MW amounts on the networked transmission lines consistent with the MW amounts required to meet CPUC resource portfolio requirements.

- A hybrid transmission solution approach involving an HVDC component and an AC networked component.

Figure F.16-2: Potential options to integrate New Mexico wind resources

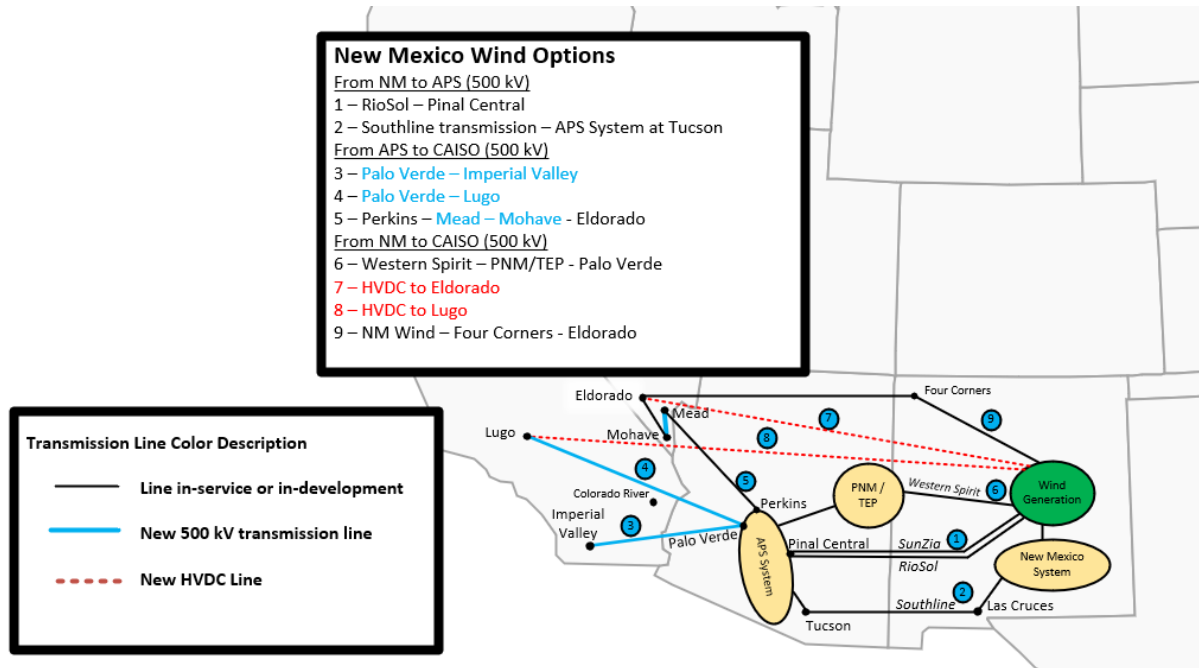

The ISO could also coordinate with the Los Angeles Department of Water and Power (LADWP) and the Balancing Authority of Northern California (BANC) to integrate OOS resources that could serve both the ISO and these entities.

The ISO will continue to engage with its state agencies, stakeholders, regional entities, transmission providers and interested parties including developers as it explores collaborative opportunities to advance beneficial and effective transmission solutions to integrate OOS resources consistent with the CPUC’s TPP resource portfolios. Apart from its participation efforts in west-wide transmission planning initiatives such as WestTEC, the ISO will also continue to work with its regional planning partners, NorthernGrid and WestConnect. It must be recognized that these coordination and engagement efforts before realizing practical, beneficial, and cost-effective transmission solutions are likely to span multiple transmission planning cycles due to the various unique challenges associated with interregional transmission development.