

APPENDIX I:
Description and Functional Specifications
for Transmission Facilities Eligible for
Competitive Solicitation

Intentionally left blank

1. Overview

As part of the draft 2025-2026 Transmission Plan, the ISO has recommended the Trout Canyon – Lugo 500 kV Line policy-driven project for approval that is eligible for competitive solicitation. More information on the project is provided in Chapter 3 and Appendix F of the draft 2025-2026 Transmission Plan. The following sections contain detailed descriptions and functional specifications for the project.

1.1. Description and Functional Specifications for Proposed Policy – Driven Trout Canyon – Lugo 500 kV Line Project

1.1.1. Description

In the 2025-2026 Transmission Plan, the ISO has identified a policy-driven need for the Trout Canyon – Lugo 500 kV Line. Figure I.1-1 provides a schematic diagram of the transmission system in the area. The project scope includes an approximately 180-mile 500 kV AC transmission line with 70% series compensation between the GLW Trout Canyon and SCE Lugo 500 kV substations.

Figure I.1 1: Schematic Diagram of the Trout Canyon – Lugo 500 kV Line project

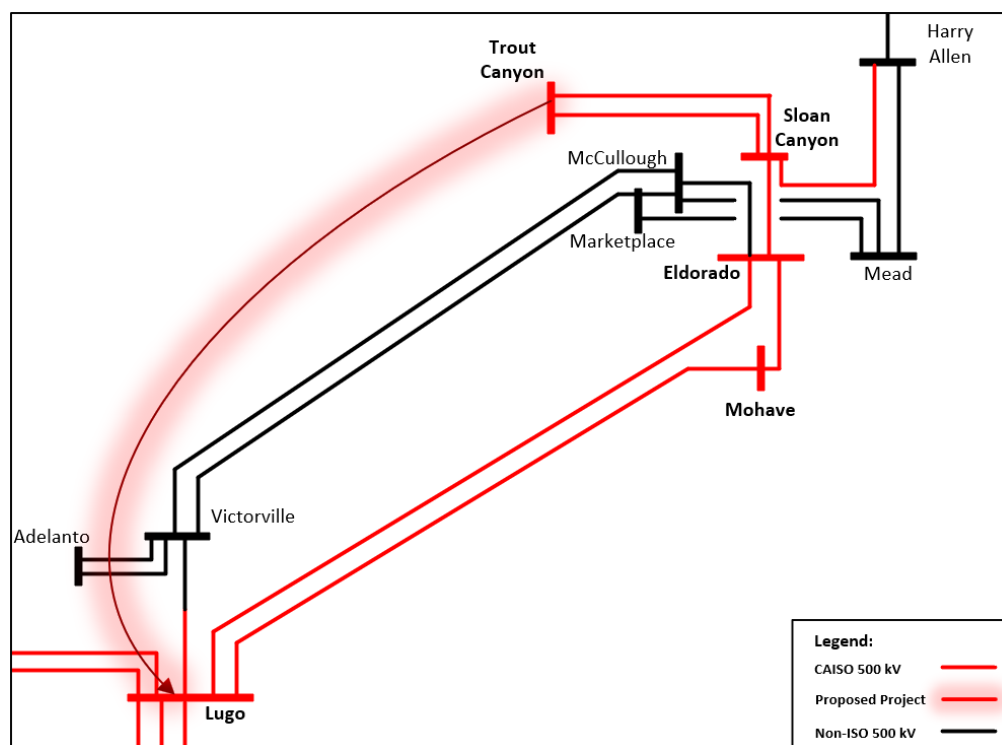

The ISO estimates that the proposed project will cost approximately \$1,270 - \$1,800 million including the estimated cost of termination at Trout Canyon and Lugo 500 kV substations. Details of cost estimate and the assumptions behind it are provided in Chapter 3 and Appendix F. The ISO recognizes there may be some uncertainty regarding routing and siting of the 500 kV AC transmission line during the siting and permitting process for this project. As such, the ISO will seek cost and risk mitigation strategies from project sponsors in their bid applications in the competitive solicitation process along with potential alternatives and mitigation measures. The required in-service date for the project is June 1st, 2035.

Beginning with the 2023-2024 Transmission Planning Process, CAISO is now requiring all project sponsors to propose an In Service Date that matches the CAISO requested In Service Date. CAISO will not attribute any value to an In Service Date earlier than the requested In Service Date.

Figure I.1-2 provides a high level diagram of the line termination and interconnection to the Lugo 500/230 kV substation¹.

Figure I.1 2: Interconnection to Lugo 500 kV Substation

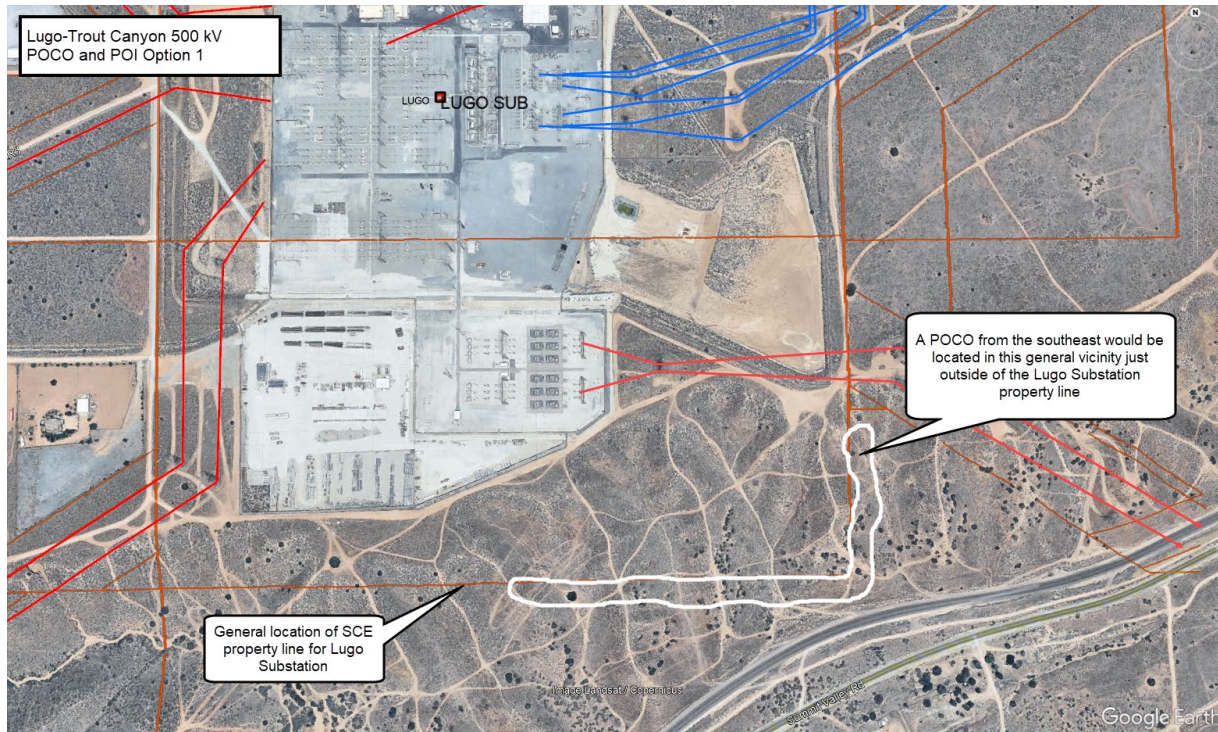

The planned Trout Canyon 500 kV station will be located in Clark County, NV and will be north of the existing Trout Canyon 230 kV facility. The illustration in Figure I.1-3 provides an approximate location of the 500 kV station perimeter in black. For reference, the existing Trout Canyon 230 kV station is shown in red.

¹ See discussion in Appendix F regarding the expected need for a second Lugo 500 kV switchyard. Which station would be the connection point for the Trout Canyon-Lugo 500 kV Line project would be determined during the interconnection study.

Figure I.1 3: Interconnection to planned Trout Canyon 500 kV Substations

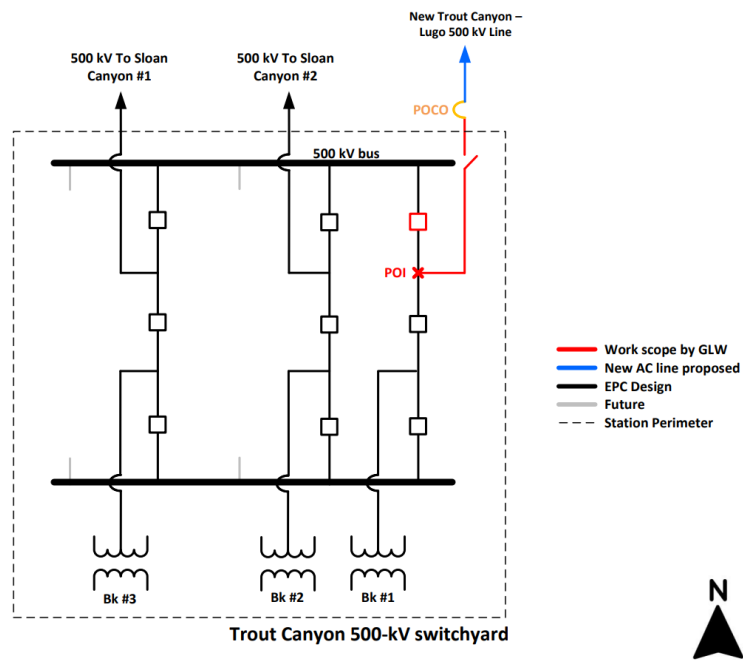
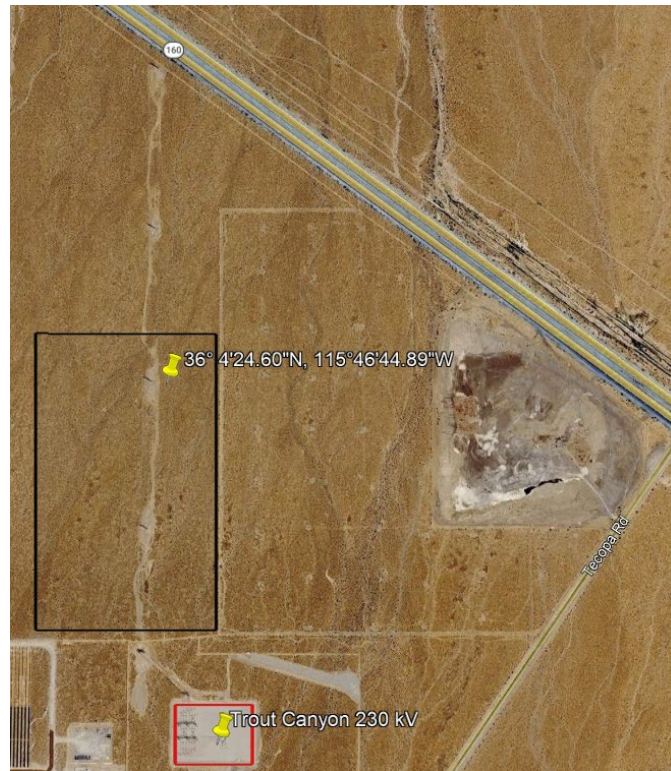

The facilities in the Trout Canyon – Lugo 500 kV Line project that are eligible for competitive solicitation are

- The new approximately 180-mile 500 kV AC line from GLW’s Trout Canyon 500 /230 kV substation to SCE’s Lugo 500/230 kV Substation.
- The required 500 kV series capacitors and line reactors

For the interconnection of the Trout Canyon – Lugo 500 kV Line project to Trout Canyon substation, the incumbent PTO (GLW) will be responsible for installing the new transmission line segment from the Trout Canyon 500 kV bus up to a point within 100 feet of the Trout Canyon substation property line. The new line segment will terminate on a dead end structure, to be owned by GLW. The approved project sponsor will be responsible for (and will own and maintain) the facilities from this last dead end structure(s) back to the Lugo 500 kV Substation.

For the interconnection of the Trout Canyon – Lugo 500 kV Line project to Lugo substation, the incumbent PTO (SCE) will be responsible for installing the new transmission line segment from the Lugo 500 kV bus up to a point within 100 feet of the Lugo substation property line. The new line segment will terminate on a dead end structure, to be owned by SCE. The approved project sponsor will be responsible for (and will own and maintain) the facilities from this last dead end structure(s) back to the Trout Canyon 500 kV Substation.

The approved project sponsor will coordinate with GLW and SCE regarding the specifications and the details of the associated line protection (e.g. current differential, directional comparison) etc. and will work with GLW and SCE to develop relay logic and detailed relay settings. Section 1.1.2 provides information related to SCE’s line protection and mid-line series capacitor requirements.

The project sponsor shall design and route the proposed transmission line in a manner that avoids configurations that could lead to the new line and any adjacent existing or planned 500 kV transmission line being considered an always credible multiple-contingency in operational planning studies. The line design shall incorporate appropriate physical separation, structural independence, and other mitigations to reduce the likelihood of common mode failures with adjacent existing or planned 500 kV transmission lines. The project sponsor shall coordinate with the owner of the adjacent existing or planned 500 kV transmission lines to evaluate and document the proposed line’s configuration to demonstrate compliance with this requirement.

As the project includes building new transmission facility with voltage level over 200 kV, the approved project sponsor will be responsible for completing the WECC Progress Report

and other processes required for this project, such as path rating process, especially the impact assessment on the West of River WECC Path (Path 46).

In seeking interconnection to SCE facilities, the approved project sponsor shall adhere to all applicable requirements in SCE's Interconnection Handbook. These include, but are not limited to, all applicable protection, voltage regulation, VAR correction, switching and tagging, and metering requirements.

1.1.2. Functional Specification for the Trout Canyon – Lugo 500 kV Line Project

Overhead Line Construction

Line Terminus 1: Trout Canyon Substation 500 kV Bus

Line Terminus 2: Lugo Substation 500 kV Bus

Nominal Phase to Phase Voltage: 525 kV

Minimum Line Continuous Ampacity - Summer: 3800 Amps

Minimum Line Continuous Ampacity – Winter: 3800 Amps

Minimum Line 4 Hour Emergency Ampacity – Summer: 4408 Amps

Minimum Line 4 Hour Emergency Ampacity – Winter: 4408 Amps

Minimum Line 30 Minute Emergency Ampacity: 5130 Amps

Minimum Series Capacitor Continuous Ampacity - Summer: 3800 Amps

Minimum Series Capacitor Continuous Ampacity – Winter: 3800 Amps

Minimum Series Capacitor 4 Hour Continuous Ampacity - Summer: 4408 Amps

Minimum Series Capacitor 4 Hour Continuous Ampacity – Winter: 4408 Amps

Minimum Series Capacitor 30 Minute Emergency Ampacity: 5130 Amps

Approximate Line Impedance including the series compensation: $0.001696 + j0.012659$ pu
(500 kV, 100 MVA base), $\pm 5\%$.

Approximate level of series compensation required: 70%

Approximate Line Length: 180 miles

Requested In Service Date: June 1st, 2035

Support Structures: Single circuit structure

Telecommunication equipment shall meet SCE's Interconnection Handbook Part 3
Transmission Interconnection Requirements Section 6.

Line Transposition Requirements: Shall meet PTOs' voltage imbalance standards

Shield Wire Required: Optical ground wire (minimum 24 pairs of fibers)

Failure Containment Loading Mitigation (anti-cascade structures, etc.): Per applicable
codes

Shield Wire Ground Fault Withstand Ampacity: Coordinate with interconnecting entities

Aeolian Vibration Control (Conductor and Shield Wire): Vibration dampers must be installed on all conductors and overhead shield wires, with the exception of slack spans.

Transmission Line Minimum BIL: 1800 kV for 500 kV, with solidly grounded systems

Minimum ROW Width: Per applicable codes

Governing Design and Construction Standards: (GO 95, Known Local Conditions to be compliant with GO 95's High Fire-Threat District maps, facilities that traverse the HFTD will require a Wildfire Mitigation Plan under PUC code 8386, NESC Code, applicable municipal codes)

Design Temperature: 50°C

Minimum 500 kV transmission line protection to include:

- Three (3) high speed line current differential protection systems, using two different vendors (i.e., L90, SEL-411L, SEL-411L), with each scheme supplied by its own current transformer (CT) and hot standby channels each.
- Digital communications consisting of six separate C37.94 compliant digital channels over three physically separate diverse routes
- For designs which utilize midline series capacitors, the requirement would be for two (2) DTB/DTT schemes (two (2) SEL-2440) with two (2) C37.94 compliant digital communication channels on two (2) diverse paths from Trout Canyon to the midline series cap and two (2) C37.94 compliant digital communication channels on two (2) diverse paths from Lugo to the midline series cap. All other Protection would be local to the substation.

Location of Series Compensation and Line Reactors:

The project sponsor shall determine the need, number of, size, configuration, and location(s) of any series capacitor(s) and line reactor(s) associated with the project while maintaining the total series compensation at approximately 70%. The costs associated with any series capacitor(s) and line reactor(s) that are not at the end of the line, shall be included within the scope of the project and shall be the responsibility of the approved project sponsor. The cost of any series capacitor(s) and line reactor(s) that are proposed to be installed at the end of the line shall be provided by the project sponsor as a separate line item so that if the interconnecting PTO requires the series capacitor(s) or line reactor(s) to be installed in their substation, the implementation of those series capacitor(s) and line

reactor(s) to be assigned to the PTO and be removed from the scope and cost of the project sponsor.