



California ISO

Hybrid Resources Final Proposal

October 16, 2020

Table of Contents

- 1. Executive summary 3
- 2. Stakeholder engagement plan 4
- 3. Definitions 5
- 4. Proposal..... 6
 - 4.1. Market interaction 7
 - 4.2. Forecasting 8
 - 4.3. Dynamic limit tool 9
 - 4.4. Master file and interconnection10
 - 4.5. Metering and telemetry11
 - 4.6. Aggregate capability constraint for co-located resources14
 - 4.7. Co-located storage deviation from dispatch15
 - 4.8. Ancillary services17
 - 4.9. Settlement17
 - 4.10. Congestion revenue rights17
 - 4.11. Market power and strategic bidding concerns18
 - 4.12. Hypothetical hybrid resource bidding19
 - 4.13. Resource adequacy26
- 5. EIM Governing Body Role29
- 6. Next Steps30

1. Executive summary

Interest in energy storage is significant and growing as state and federal policy makers and regulators support energy storage development and believe in its ability to help decarbonize the grid. In California, energy storage paired with wind and solar may reduce reliance on natural gas fired generation and help the state achieve its energy policy goals. Interconnection customers have submitted a significant number of interconnection requests for projects that incorporate stand alone and hybrid energy storage resources in response to this direction. The ISO anticipates the quantity of mixed-fuel resources will increase significantly in the coming years. Today, there is about 550 MW of storage and hybrid resources interconnected to the ISO grid, but the ISO anticipates about 1,500 MW of these resources by the end of 2021 and continued rapid growth over the next few years. These resources make up a majority of the interconnection queue for new resources coming onto the system in the future.

The ISO is committed to enhancing the participation of energy storage in the ISO's markets and continues to work with stakeholders to identify potential new or enhanced market rules and business processes needed to accommodate the unique attributes of energy storage. In anticipation of hybrid resources connecting to the grid, the ISO developed a hybrid resources technical bulletin in 2016 to provide initial guidance.¹

Resource developers are combining generation technologies such as gas, solar or wind projects with energy storage to create enhanced resources for grid operations and systems that qualify for investment tax credits. The ISO received many inquiries from interconnection customers interested in developing such projects, and is anticipating that development of hybrid and co-located resources will accelerate over the coming years.

The ISO launched this stakeholder initiative to identify potential new or enhanced market rules and business processes needed to accommodate hybrid resources. The ISO proposes two sets of market rule changes within this initiative to facilitate mixed-fuel type projects (i.e. hybrid and co-located resources) participation in the ISO's markets. The first set of modifications generally concern setting up and operating co-located resources and was approved by the ISO Board of Governors in July. The ISO anticipates implementation of these changes in the market on December 1, 2020. The second set of modifications, detailed in this proposal, focuses on hybrid resources and includes some changes to treatment of co-located resources. The ISO plans to present market rule changes for co-located resources to the ISO Board of Governors for approval in November 2020, and implement these changes in fall 2021.

Updates for Outage Submission

The ISO received significant feedback from stakeholders on the outage submission process and in response has simplified the process for submitting outages and for use of the dynamic limit tool. This proposal outlines specific rules that hybrid resources will need to adhere to when submitting outages, which includes submitting outages for typical mechanical issues. These

¹ Hybrid Resources Technical Bulletin, 2016: <https://www.iso.com/Documents/TechnicalBulletin-ImplementationofHybridEnergyStorageGeneratingFacilities.pdf>.

outages will be consistent with outages that other resources on the ISO grid must adhere to when submitting outages. However, hybrid resources will also have access to the dynamic limit tool, where ambient outages and unavailability due to changes an underlying variable energy component may be captured. The ISO believes this change addresses this stakeholder concern and simplifies the approach to unavailability for hybrid resources. The ISO has also worked to ensure that this methodology can be accommodated in the proposed changes to the resource adequacy program.

2. Stakeholder engagement plan

Date	Milestone
October 5	Publish final proposal for hybrid resources
October 15	Stakeholder teleconference
October 29	Comments on the final proposal due
November 4-5	EIM Governing Body
November 18-19	ISO Board of Governors meeting for hybrid proposal
December 1, 2020	Implement co-located proposal, without AS
February 2021	Implement allowance for storage resources to deviate down
Fall 2021	Implement hybrid and full co-located proposal

3. Definitions

The ISO proposes the following definitions:

Hybrid Resource: “A Generating Unit, with a unique Resource ID at a single Point of Interconnection, with components that use different fuel sources or technologies.”

The ISO recognizes that this definition may not be universal. For example, pairing a small amount of energy storage with a conventional generator where the storage would only be used to meet station power demand may not require any treatment unique to hybrid resources beyond how the resource is initially studied and modeled. The proposed hybrid resources definition will not apply to multi-stage generators or other resource configurations that have multiple units of a single fuel-type or single generation technology.

The ISO also proposes to require that hybrid resources meet the minimum sizing requirements for both of the underlying generation components: 500 kW for any participating generator hybrid resource component and 100 kW for any storage hybrid resource components.² The ISO has clarified this aspect of the proposal to avoid confusion regarding the sizing requirements for hybrid resources.

Co-located Resource: “A Generating Unit with a unique Resource ID that is part of a Generating Facility with other Generating Units. An EIM Participating Resource with a unique Resource ID that is part of a single resource with other EIM Participating Resources.”

The concept of the co-located resource is that there could be a combination of multiple different generation technologies of different fuel types behind a single point of interconnection that each participate in the ISO markets as distinct resources with their own market resource ID. The collection of resource behind the point of interconnection are optimized by the ISO’s market using the entire collection of bids or self-schedules. Each resource is individually metered and telemetered. Co-located resources may be comprised of one or more variable energy resources or resources that are not variable energy resources.

² ISO Tariff Section 4.6.3.2 requires participating generators to be 500 kW or greater. Pursuant to Order No. 841, the ISO has proposed to lower the minimum capacity requirement for storage resources to 100 kW, effective December 3, 2019.

4. Proposal

This draft final proposal outlines rules for hybrid and co-located resources, including market participation rules, forecasting requirements, ancillary services eligibility, metering requirements, and implications for participation in the resource adequacy program. These proposals are summarized by the following list, and details are provided in each of the subsections below. The policy outlined in this document will go before the ISO Board of Governors for approval at the November 2020 meeting. The ISO will then implement the policy allowing co-located storage (Section 4.7) to deviate from dispatch under certain conditions. This particular co-located resources capability will be implemented as quickly as possible since this capability requires no software development. The remainder of the hybrid resource policy will be implemented with the fall software release in 2021. The ISO completed its initial policy proposals for co-located resources, which was approved by the ISO Board of Governors in July, 2020 – and will implement this policy on December 1, 2020. Complete details for the policy proposed there were included in the second revised straw proposal for the hybrid resource initiative.³

Key Policy Proposals:

- (4.1) Hybrid resources will have access to the same bidding tools as other resources
- (4.1) Hybrid resources will be expected to follow ISO dispatch instructions
- (4.1) Hybrid resources are required to submit state of charge data to the ISO
- (4.1) Hybrid resources are required to submit outage cards for ~~energy not available~~mechanical outages
- (4.2) Hybrid resources are not VER resources, but will have access to dynamic limits
- (4.2) Hybrid resources will submit meteorological data for all VER components
 - Hybrid resources will be required to have meteorological equipment installed
 - Meteorological data for hybrid resources will include the high sustainable limit
- (4.2) Co-located variable energy resources will provide a high sustainable limit
- (4.2) ISO will offer forecasting services for VER components of hybrid resources
 - Hybrid resources may self-provide forecasts to the ISO for VER components
- (4.3) Hybrid resources will have access to a “dynamic limit” tool in RT, similar to VERs
 - Hybrid resources will self-submit dynamic limits to real-time bids
 - Hybrid resources can use ISO forecasts to inform dynamic limits
 - Dynamic limits will cover ambient and VER unavailability
 - Dynamic limits need not be duplicative of outage cards
- (4.4) Hybrid resources will be modelled using the NGR model
- (4.5) Hybrid resources will provide metering data at their point of interconnection
- (4.5) Hybrid resources will provide metering data for all VER components
- (4.7) Co-located storage may produce less than dispatch under certain circumstances:
 - The co-located VER resource must be producing above dispatch

³ Hybrid resources policy page: <http://www.caiso.com/StakeholderProcesses/Hybrid-resources>.

- The co-located resource would otherwise be producing above POI limits
- The co-located resource will bear burden of procuring all information necessary
- The co-located resource may not be providing ancillary services
- All energy absorbed would be charged UIE
- (4.8) Hybrid and co-located resources may provide ancillary services
- (4.12) The ISO encourages hybrid resources to bid charging capacity into the grid
- (4.12) ITC resources may receive special modeling considerations in DEB
 - These will only be granted for resources that cannot recover costs from economically bidding into the market
- (4.13) Must offer obligations and counting will not change for co-located resources
 - Obligations will be based on individual resource type
- (4.13) Hybrid resources will count for credit in the manner outlined by the CPUC
 - Hybrid resources will be subject to UCAP after implementation of RAE
 - ~~Dynamic limits~~ Hybrid resources will not be subject to RAIM
- (4.13) ITC resources may receive special modeling considerations in DEB
 - These will only be granted for resources that cannot recover costs from economically bidding into the market

4.1. Market interaction

Hybrid resources will be optimized and dispatched by the ISO in the day-ahead and real-time markets like other resource types. Hybrids will receive market awards based on cleared schedules and bids submitted in the real-time market 75-minutes prior to the operating hour. The ISO will expect hybrid resources to follow all ISO market awards and dispatch instructions, and will assess uninstructed imbalance energy (UIE) at the real-time market prices for any deviations from dispatch instructions.

To address timing risk between bid submission and dispatch, the ISO is offering a dynamic limit tool, which can limit the dispatch instruction from the ISO for portions of the bid curve that are unavailable for dispatch based on actual production limitations for the hybrid resource. The dynamic limit tool is discussed further in section 4.2 below.

The ISO will not optimize state of charge for hybrid resources. However, hybrid resources will be required to submit this information to the ISO, which will be submitted to the ISO along with other telemetered values. This information may be used to by the ISO to verify that hybrid resources were capable of meeting dispatch instructions. Resource operators will need to manage the state of charge of any storage component through typical bidding patterns and submissions of the upper dynamic limit.

Hybrid resources will be responsible, like other resources on the system, for notifying the ISO whenever they are not available for dispatch. Onsite charging is a feature that many hybrid resources have asked for, but this feature inherently reduces the availability of a hybrid resource for dispatch from the ISO market. This reduction in dispatch capability must be captured ~~in~~ outage cards and, submitted to the ISO through the ISO's outage management system dynamic

limit tool. Similarly, a hybrid resource may be comprised of a variable energy component, which may not be able to physically produce at full, or any output, at certain times of the day based on fuel availability. These outages would also be submitted to the ISO through the dynamic limit tool, in the real-time market. Examples of this are illustrated in section 4.12 below.

4.2. Forecasting

Today, the ISO classifies wind and solar stand-alone resources as variable energy resources (VERs). The ISO uses forecasts for these resources to determine an upper economic limit that they may receive for a market award through ISO dispatch. This allows variable energy resources additional flexibility when bidding into the ISO markets, particularly in real-time.

As an example, the sun may be rising and solar output at a specific resource may be increasing from 50 MW, to 52 MW, to 55 MW during three specific consecutive five minute intervals. Participating resources are only allowed to submit one bid curve applicable for each hour, which cannot be adjusted during that hour, inclusive of solar resources. The ISO has market rules that limit the upper range that a solar resource may be dispatched to in the real-time market. For this example resource, the ISO would be limited to sending a dispatch instruction that is equal to or less than the forecast value. This ensures that the resource receives a feasible dispatch instruction, which includes information from the most recent ISO forecast. This also helps limit the resource's exposure to deviation charges, which are calculated based on the difference between what the resource produced and the ISO dispatch instruction.

This tool uses forecasts generated either by the ISO, or may be submitted to the ISO from the variable energy resource owner.

The ISO proposes to not classify hybrid resources as variable energy resources, even though hybrid resources may include a wind or solar component. The ISO will offer forecasting services for the wind or solar component(s) of the hybrid resources, similar to what is provided to stand-alone variable resources today. These forecasts will only be for the variable (solar or wind) component of the hybrid resource and are not meant to provide a forecast for the entire output of the full hybrid resource. These forecast services will be optional, and resource owners can elect not to receive and pay for this ISO service.

If resource owners do not elect to have the ISO generate a forecast for the VER component of a hybrid resource, and the resource includes a wind or solar component, it will be required to provide meteorological information as well as forecasts for any variable components to the ISO. This means that if a hybrid resource with a solar and storage component interconnects to the grid, the ISO will require the same information about the operation of the solar resources (effectively behind the hybrid meter) as would be required of a stand-alone solar resource. This will ensure that the ISO is able to predict renewable generation and variability of output at a specific electrical location, for the purposes of reliability.

Wind or solar resources as a component of a hybrid resource will be required to submit 1) a topographical map, 2) site information sheet (designating either ISO or scheduling coordinator forecasts), 3) real-time meteorological station data (with meteorological stations in accordance

with Appendix Q, Section 3.1), 4) real-time forecast data (if scheduling coordinator provided), 5) real-time telemetry data, and 6) the high sustainable limit. The high sustainable limit (HSL) is a measurement that was outlined in detail in the revised straw proposal, and essentially is a real-time telemetered estimate of what the variable component is capable of producing. In response to stakeholder questions about specifics of the high sustainable limit, the ISO generated a white paper with details for how this value should be reported to the ISO and why it is needed.⁴

Variable energy resources that are co-located will also be required to provide high sustainable limit data to the ISO. This data will be the same that is collected for the hybrid resources. The ISO may pursue and use high sustainable limit data received by a co-located VER or hybrid VER component to improve variable energy resource forecasting, inform regulation requirements, and inform uncertainty risks across the system. The high sustainable limit may also be used in the future by the ISO to construct dynamic limits. This proposal includes allowing dynamic limits to be submitted by hybrid scheduling coordinators to the ISO, but in the future the ISO may prefer if this were an automated function of state of charge and high sustainable limit.

4.3. Dynamic limit tool

The ISO proposes a “dynamic limit” tool, which will be used to limit the economic dispatch of a hybrid resource in the real-time market, similar to the tool that limits the upper economic dispatch of variable energy resources today. These two tools would be fundamentally different. The tool for the variable energy resources is derived by the ISO and generated strictly from the forecast of the variable energy resource. The dynamic limit tool proposed for hybrid resources will only be determined based on values submitted to the ISO from the hybrid resource scheduling coordinator. These values will limit the dispatch instruction for the hybrid resource in the positive or negative direction. The dynamic limit tool will be the tool available to scheduling coordinators to ensure that hybrid resource schedules are infeasible, based on potential state of charge conditions, renewable availability, internal storage charging schedules, etc. Both tools will only be available to resources in the real-time market, and will not be available in the day-ahead market.

The dynamic limit tool requires that the upper and lower economic limit be submitted to the ISO each 5-minute interval. Dynamic limits will be updated once every five minutes, and for hybrid resources will include limits for each 5-minute interval in a three hour window, for each submission. The ISO anticipates that resources will use forecast values from variable energy resource components to inform dynamic limits, as these will likely be drivers to how much energy the resource can deliver to the market. If the forecast values for the variable energy component is generated from the ISO, there may be lag between when the forecasts are generated and when they are imposed as limits for the dynamic limits for hybrid resources. This lag will be the result of the time the ISO takes to generate the forecast data and transmit that to

⁴ Hybrid resources policy page: <http://www.caiso.com/StakeholderProcesses/Hybrid-resources>.

the hybrid operator, receipt of that data and processing, and finally submission of the data to the ISO for use as a dynamic limit.

Stakeholders submitted a significant amount of feedback on the proposed methodology for the use of outage cards and the dynamic limit tool to convey availability to the ISO for hybrid resources. Many of these comments noted the burden of submitting outage cards for hourly unavailability for hybrid resources, as these values would change on an hourly basis for variable resources and may need to be updated often as future forecasts for variable components change. Today, the ISO's outage management system (OMS) takes manual entries for resources on outage and is not automated. This manual process combined with the high number of outages and updates would be difficult for scheduling coordinators to maintain. Commenters also added that because the ISO is already planning to collect dynamic limit data for hybrid resources, outage cards may be duplicative and not necessary.

The ISO initially proposed to collect hourly outage data for any unavailability through the outage management system. This was because the ISO is proposing to use data from the outage management system to calculate the unforced capacity (UCAP) for use in the resource adequacy enhancement initiative.⁵ These unforced capacity values will be used to determine the amount of resource adequacy capacity that resource owners may provide in the resource adequacy framework.

After considering stakeholder feedback, the ISO is updating the final proposal to simplify the use of outage cards and dynamic limits for hybrid resources. The ISO updated this proposal to include changes that will alleviate the concerns raised by stakeholders, simplify the use and submission of outage cards, and continue to allow for the correct calculation of resource adequacy in the future. Specifically, the ISO proposes that hybrid resources continue to use the outage management system to report mechanical related outages to the ISO. Further, the ISO proposes that hybrid resources use dynamic limits to report any reduction in potential output due to ambient conditions, limitations on underlying variable energy components, or limitations from having restrictions due to state of charge (i.e. either full state of charge or empty state of charge). The ISO is proposing no new changes to the state of charge requirement, which will still be submitted for every 5-minute interval, and will include a three hour horizon of limits for each 5-minute interval.

4.4. Master file and interconnection

Resources that seek to charge from the grid at any point must be modelled in the ISO's master file system as a non-generator resource (NGR) facility, which offers the ability to charge from the grid (dispatch less than 0 MW) as well as the ability to provide energy to the grid (dispatch greater than 0 MW). The ISO expects that most hybrid resources will elect to use the non-generator resource model for their resources. The corresponding fuel type for such hybrid resources will be "other," as the underlying components of the resource will likely be multiple fuel types. Hybrid resources will not receive treatment as a variable energy resource, eligible

⁵ Resource Adequacy Enhancements initiative:
<https://stakeholdercenter.caiso.com/StakeholderInitiatives/Resource-adequacy-enhancements>.

intermittent resource (EIR), or a participating intermittent resource (PIR), although some of the requirements may be similar (like submitting meteorological data).

Modelling and interconnection requirements are tailored to each interconnection request. Each hybrid resource will be reviewed by the ISO and evaluated on an individual basis. Some resources with multiple fuel types may not be categorized by the ISO as non-generating resource types. For example, if a gas-fired resource undergoes plant augmentation and adds a relatively small battery to the resource to enhance its ramp capabilities, ancillary service capabilities, and upper economic bound, the ISO may choose to continue modelling such a resource as a gas-fired generator given its operating behavior remains fundamentally unchanged. For hybrid resources that have a relatively similar capacity between renewable generation and storage, these will generally fit into the non-generator resource model. Ultimately, however, the ISO cannot issue a charging schedule to any resources unless it is a non-generator resource or pumped storage hydro unit.

Components of hybrid and co-located resources also will be studied independently when interconnecting with the ISO. Each component of these resources will be studied as synchronous or asynchronous individually, where wind, solar and storage resources are asynchronous, and gas and hydro resources are synchronous.

4.5. Metering and telemetry

Telemetry and metering record the net output of a resource. Additional data and telemetry points may be required for hybrid resources providing ancillary services and hybrid resources that include renewable components.

For hybrid resources that are not providing ancillary services, the ISO will not require separate metering and telemetry requirements for each underlying component of a hybrid resource, but only the renewable resource component(s). The ISO will use the data and telemetry from the wind and solar resource components of a hybrid resource for reporting purposes. In the future, this data may be used for additional purposes including: forecasts for the renewable component of the resource when the hybrid resource selects the ISO to provide forecasting services, limits on regulation that may be scheduled, and uncertainty risk for system operations.

The ISO is registered with the WECC as a qualified reporting entity (QRE) and reports meter data for renewable resources using the western renewable energy generation information system (WREGIS).⁶ Including metering and telemetry data for all renewable components of hybrid resources will allow the ISO to continue providing the following four functions: 1) WREGIS reporting, 2) visibility into actual operations and ISO's ability to meet all NERC real-time control standards, 3) providing public data for load served by renewables in real-time, and 4) providing aggregate information to the CEC and CPUC to measure progress toward the state's energy and environmental goals.

⁶ For additional information on the western renewable energy generation information system refer to the following link: <https://www.wecc.org/WREGIS/Pages/default.aspx>.

The ISO intends to work closely with interconnection customers during the market implementation of new hybrid resources to ensure that the metering configurations allow for RPS reporting and any necessary netting and loss calculations.

The ISO notes that it will consider all relevant CEC renewable portfolio standard reporting guidelines applicable to hybrid resources when determining the necessary calculations and reporting activities. The ISO will also consider any other applicable regulatory guidelines for renewable portfolio reporting.

Figure 1 shows a metering diagram on the left, for a co-located resource, and a metering diagram on the right, for a hybrid resources. Most resources on the ISO grid have unique metering requirements, and co-located and hybrid resources are anticipated to have unique requirements as well. The ISO metering team reviews metering plans for new resources and verifies that these plans meet ISO standards for reporting. In both cases, metered output is compensated at the ISO point of interconnection.

The ISO accommodates co-located resources today, and requires accurate information for energy flowing from each resource across the point of interconnection, inclusive of losses, to the grid. The metering diagram in Figure 1 shows three meters, one at the DC line from each component of the co-located resource, with this example being specific to DC-coupled resources. These meters are required to distinguish between energy coming from a particular resource. The diagram also shows a meter at the point of interconnection. This meter is not required, if the actual amount of injected energy can be determined from the meters at the resource level. As noted above, metering may be required for any renewable components of a hybrid resource for state reporting purposes. Further, the ISO will require accurate metering for energy at the point of interconnection, whether this be a meter directly at that location, or individual meters at each component of the hybrid resource.

Figure 1: Simple DC Metering diagram for a co-located (left) and hybrid resource (right)

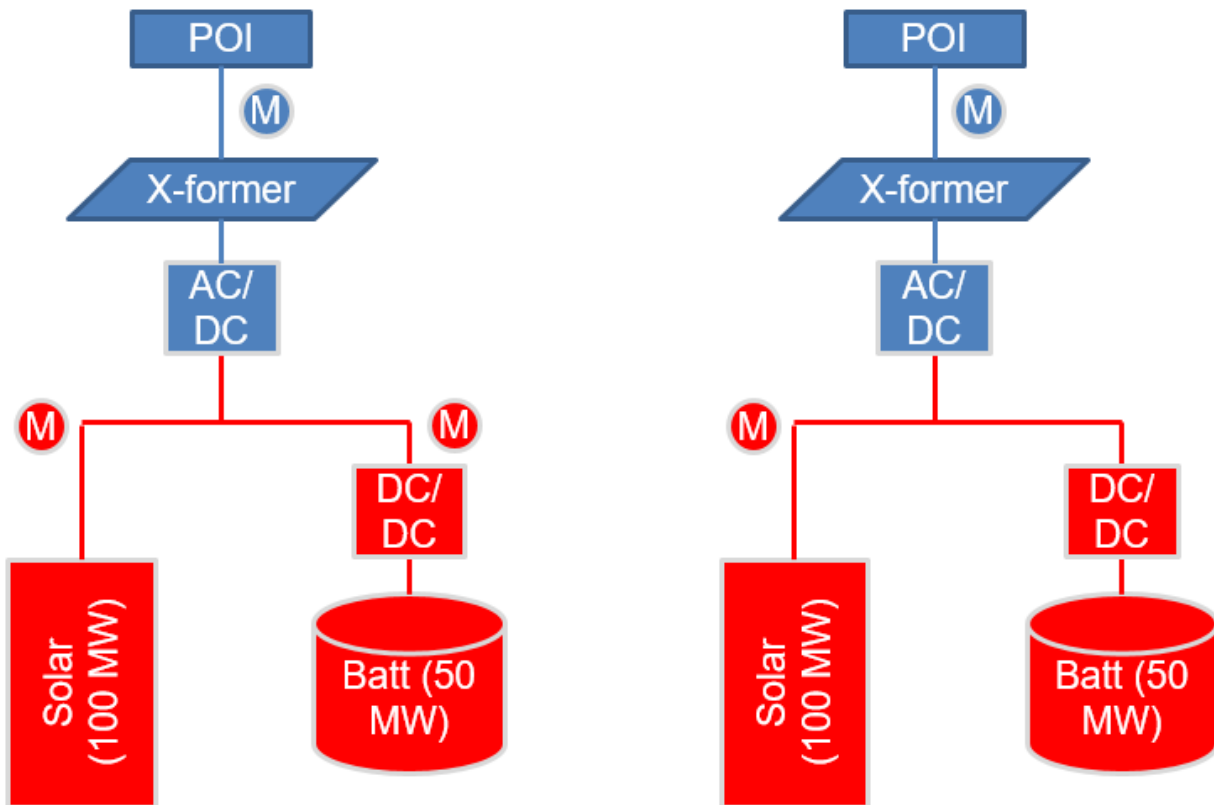

The ISO currently has not identified DC meters that can provide settlement quality meter data to the ISO. However, the ISO understands that hybrid and co-located resources may want to be DC coupled, to improve efficiency and reduce costs to charge on-site storage components. The ISO is working with vendors and market participants to identify a DC settlement quality meter data that can be used for this purpose, with a goal of having such a meter identified at or around the time that this policy is implemented. Figure 2 shows how a metering configuration may work for an AC coupled hybrid or co-located resource. As previously noted, all metering configurations are approved by the ISO before resources can submit meter data. Additionally, resources may have unique metering configurations that may not precisely match the highly simplified line diagrams in Figure 2. There are other potential ways to position the meters to get the same settlement data to the ISO.

Figure 2: Simple AC Metering diagram for a co-located (left) and hybrid resource (right)

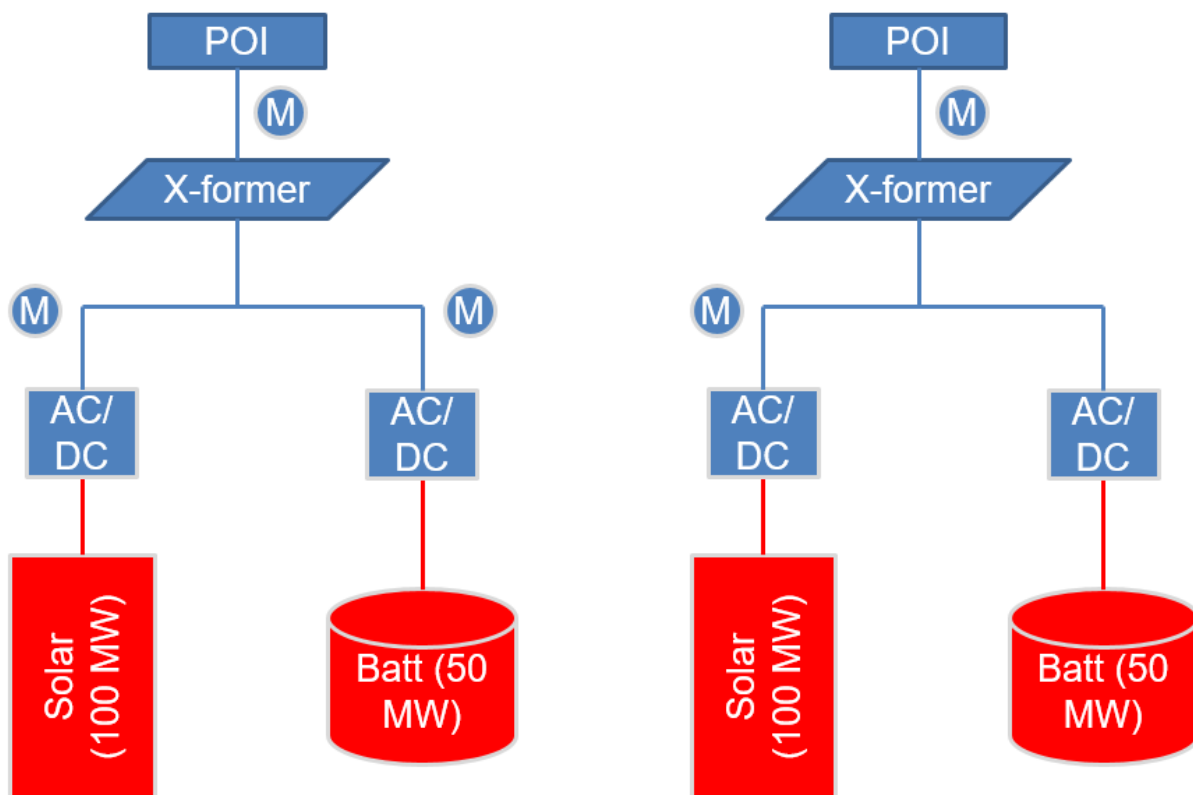

4.6. Aggregate capacity constraint for co-located resources

The ISO presented an aggregate capacity constraint for energy bids only contained within the second revised straw proposal, which was approved by the Board of Governors in July 2020, and will be implemented in fall 2020. This methodology will be enhanced with the full implementation of the aggregate capacity constraint, inclusive of ancillary services, which will be implemented in fall 2021, and is included here in this proposal.⁷

In the second revised straw proposal, the ISO explained how the aggregate values for the Pmax of each resource under a co-located project may not exceed the total interconnection rights at the point of interconnection for the underlying co-located resources. This prevented co-located resources from showing their actual operating capability in their Pmax and bidding ranges in the market. The ISO proposed, and received Board approval to allow resources to register their maximum operating limit as their Pmax, even if the aggregate values of these maximum operating limits are greater than interconnection rights set forth in their generator interconnection agreements. Using the aggregate capacity constraint functionality, the ISO will limit market awards and dispatches from co-located resources to the total amount of interconnection service rights held by that co-located resource project. The CAISO will

⁷ Hybrid resources policy website: <http://www.caiso.com/StakeholderProcesses/Hybrid-resources>.

implement this new aggregate capability constraint, which only considers energy and not ancillary services, in fall 2020. The ISO proposes here to enhance this constraint to enable ancillary service provision by fall 2021.

Formulation

The ISO proposes to use the following formulation, which will include ancillary services and energy, for the full implementation of the aggregate capability constraint for co-located resources. The full constraint follows:

$$MAX \left[0, \sum_{i \in S} (EN_i + RU_i + SR_i + NR_i + FRU_i) \right] \leq UL$$

$$MIN \left[0, \sum_{i \in S} (EN_i + RD_i + FRD_i) \right] \geq LL$$

Where:

<i>i</i>	Resource
<i>S</i>	Set of resources
<i>EN</i>	Energy schedule
<i>UL</i>	Upper limit
<i>LL</i>	Lower limit
<i>RU</i>	Regulation up award
<i>RD</i>	Regulation down award
<i>SR</i>	Spinning reserve award
<i>NR</i>	Non-spinning reserve award
<i>FRU</i>	Flexible ramp up award
<i>FRD</i>	Flexible ramp down award

4.7. Co-located storage deviation from dispatch

As noted earlier, the makeup of the grid is changing considerably and the state of California is moving toward goals to produce energy more from renewable resources. The ISO received a number of comments to the second revised straw proposal asking that the co-located storage resources be allowed to deviate from dispatch instructions when co-located variable energy resources were also deviating from instructions and producing as capable. The ISO understands that the request is related to allowing generation from renewable resources, when they may otherwise be curtailed at a point of interconnection. An improved outcome could be to have the onsite storage absorb the generation above the point of interconnection, potentially allowing for the maximum amount of generation from the renewable resource.

In light of these stakeholder requests, the ISO proposes to allow this functionality from co-located storage resources but with specific limitations, some of which will reduce implementation burdens for these tools.

This functionality will:

- Allow co-located storage resources to produce less than dispatch under the following circumstances:
 - The co-located VER resource must be producing above dispatch
 - The co-located resource would otherwise be producing above POI limits
 - The co-located resource may not be providing ancillary services
- Burden of all information sharing necessary would be borne by the co-located storage, rather than the ISO
- All energy deviations from dispatch would be charged UIE

By implementing this functionality with these parameters, market participants could configure co-located generating units at a single Generating Facility to allow a VER generating unit to produce as capable beyond its dispatch operating target and store that electricity for future discharge to the system.

The ISO proposes that co-located storage resources may deviate from their dispatch instructions from the ISO under certain circumstances.

This would only occur when a co-located variable energy resource was capable of producing above its dispatch instruction. Further, it must be the case that this energy would otherwise not be produced, i.e. if the co-located variable energy component generating producing at maximum possible output and the co-located storage producing at its dispatch level cause the co-located resources to exceed the point of interconnection limit. To provide a numerical example, suppose a co-located solar and storage resource are behind an aggregate capability constraint of 50 MW. The forecast for the solar component and is 45 MW and the resource is allowed to produce as capable. However, as the interval starts, the actual solar generation capable from the solar resource is 55 MW. In this case, the solar is allowed to produce the full 55 MW, and for the storage resource to respond and charge at 5 MW, leaving the aggregate generation from the two resources at 50 MW, which is the aggregate capability constraint limit. It is not permissible for the storage resource to deviate further, without additional output from the solar resource.

The ISO understands that there may be a need for automated communications and controls to take advantage of this functionality. If a co-located storage resource wants to use this functionality, they are solely responsible for managing these communications and controls and must demonstrate to the ISO's satisfaction that these controls will functional properly.

There will be no changes to the way that settlements are calculated today. This means that any deviation from co-located storage resources will count as uninstructed energy, and will be assigned any costs, including charges for flexible ramping product procurement, associated with that energy.

Because storage resources would only be allowed to capture additional energy produced from the variable energy resources, this implies that co-located storage would only ever deviate from dispatch instructions in the downward (charging) direction. As a result, storage resources would always have a charge greater than or equal to the anticipated state of charge from dispatch.

Co-located storage resources that are receiving automatic generator control (AGC) instructions from the ISO as a result of regulation awards are not allowed to ignore these instructions from the ISO. Further, the ISO will not allow any co-located storage resource providing ancillary services to deviate from dispatch instructions during the dispatch intervals when they have ancillary service awards.

4.8. Ancillary services

All resources, including hybrid and co-located resources, will be eligible to participate in the ancillary services market, and will be subject to the same ancillary service eligibility requirements as other participating resources.⁸ Ancillary services consist of spinning reserve, non-spinning reserve, regulation up and regulation down.

Through telemetry, the ISO will require verification that hybrid resources with an ancillary services bid or qualified self-provision are available and can perform. Telemetry requirements for hybrid resources will mirror those for conventional resources. The ISO will perform ex post validation that resources are able to provide all scheduled ancillary service awards consistent with its tariff and Business Practice Manuals

4.9. Settlement

The ISO does not envision significant changes to the settlement process in place today with the introduction of this policy. As noted above, hybrid resources will receive dispatch instruction from the ISO based on the single set of bid curves and the dynamic limit values submitted for the resource. The hybrid resource will then be required to deliver that energy to the point of interconnection. Failure to do so exposes the resource to typical uninstructed imbalance energy charges and no pay provisions, as applicable.

4.10. Congestion revenue rights

Congestion revenue rights (CRRs) are sold today between generation and load. The generation nodes are modelled for each different generator on the grid. These locations may be

⁸ Tariff appendix K discusses specific guidelines for ancillary service qualifications. In the second revised straw proposal, the ISO proposed implementation for a model for co-located resources, subject to an aggregate capability constraint, that would be allowed to provide energy, but not ancillary services, to the market. Upon implementation of this policy, the ISO proposes that co-located resources be allowed to provide ancillary services, in addition to energy services. Hybrid resources policy: <http://www.caiso.com/StakeholderProcesses/Hybrid-resources>.

modelled in a similar way for co-located resources: at the Pnode for the generator or the point of distribution (POD).⁹

The ISO worked hard over the last few years to align constraints in the day-ahead market with constraints in the congestion revenue rights market. Introducing the aggregate capability constraint for co-located resources will create an inconsistency between the day-ahead market and the market modeled for congestion revenue rights. Under current design, the congestion revenue rights model does not have a feature to remove the impacts of congestion from an imposed constraint. This will result in potentially different pricing outcomes between the day-ahead market and the congestion revenue rights market. Because this congestion is not observed in the day-ahead market this will tend to put a price premium on congestion revenue rights at co-locations.

The impacts to the parties who would buy congestion revenue rights will likely be small, as there will be a relatively small number of co-located resources and capacity on the system in the next few years. This difference in pricing is also likely to not incentivize gaming as the congestion revenue rights may appear relatively more expensive than they would otherwise be.

The ISO could potentially introduce an update to the congestion revenue rights software to align this difference immediately, however, this software change could be complicated and costly to actually implement. Instead, the ISO proposes to include this as an item in the planned overhaul for the congestion revenue rights market software that is scheduled for spring 2022.

4.11. Market power and strategic bidding concerns

The ISO will monitor all hybrid resource forecasts and bids for strategic behavior. The ISO requires that hybrid resources bid in their full capability like other resources on the system understanding that hybrid resources have periods when they may charge underlying storage components, and periods where energy is coming from potentially variable sources. The ISO intends to collect forecast data on the variable resource components as well as bid and outage data. The ISO intends to use this information to monitor, check and understand hybrid resource bidding practices. Bidding requirements and must offer obligations are discussed further in Section 4.13.

The ISO also recognizes that there could be several thousand megawatts of hybrid capacity on the system in the next few years, including some projects in local areas with thin capacity margins. Projects located in these areas have a greater potential to exercise market power. The ISO is not planning to implement market power mitigation at this time, but will likely include this capability in a future version of the hybrid resources initiative to address this concern.

⁹ The POD is used when losses are greater than 2%.

4.12. Hypothetical hybrid resource bidding

A number of market participants asked that the ISO explain how bidding might work for a hypothetical hybrid resource and how bidding might work for resources that were receiving investment tax credits. This section describes how such a process might work.¹⁰

The day-ahead and real-time markets function similarly. The market software minimizes total expected costs to serve load across the system over a specific time horizon. One notable difference between the two markets is that the day-ahead market solves for a 24-hour time horizon producing hourly schedules for resources in the footprint, while the real-time (RTD) market includes an hour long time horizon and solves each 5-minute interval. The day-ahead market includes load variation across the entire day including the morning ramp, the afternoon solar generation, and the evening ramp. This allows the market to optimally plan for the use of storage resources over the entire day. This would include periods to charge and discharge storage resources, considering the maximum amount of energy those storage resources are capable of charging.¹¹ The real-time market does not consider the hourly schedules awarded in the day-ahead market, and will only compare the energy needs in that market, with the bid in prices from the resources available during the interval the market is solving.

Storage resources bidding into the day-ahead market need not vary their bids each hour to anticipate price formation throughout the day. They also may not necessarily want to self-schedule into the market during specific hours, to “catch” the highest prices of the day. This is true, because the day-ahead market will optimize over the full 24-hour period and manage state of charge for these resources and manage state of charge while managing the market. Thus, the market internalizes the opportunity costs of discharging a storage resource during any particular interval. For example, if the market chooses to discharge a storage resource during hour ending 13 it inherently knows that the storage resource has one less hour of state of charge to use during later hours of the day. This is not the case for hybrid resources. The ISO will not manage state of charge for hybrid resources in the real-time and day-ahead market, and will therefore not internalize opportunity costs for running a storage resource and depleting state of charge for storage components of hybrid resources. Hybrid resources must therefore internalize these costs in their bids.

The ISO presents a hypothetical hybrid resource, comprising of: 1) a 100 MW solar facility; 2) a battery capable of charging from the grid at up to 100 MW, discharging at up to 100 MW and storing between 0 MWh and 400 MWh of energy; and 3) an interconnection limit allowing 100 MW to flow from the grid to the facility and up to 200 MW to flow from the facility to the grid. Assume that the solar resources is receiving an investment tax credit resulting in a marginal cost to operate the resource at -\$15/MWh. Also assume that cost to charge the battery component of the hybrid resource is \$20/MWh, which represents battery degradation and

¹⁰ The ISO cannot instruct a resource how to bid in the market. That is the sole responsibility of the resource scheduling coordinator. The following section is simply meant to serve as an illustration of how bids might work within the ISO market construct.

¹¹ Most planned and installed storage resources operating on the system are 4-hour duration batteries. For a 100 MW resource, this implies a 400 MWh energy storage capacity.

additional operation and maintenance costs. Finally, that the battery starts the day at a 100 MWh state of charge and the charged energy cost the hybrid resource \$20/MWh. For now, we also make the further simplifying assumptions that the resource is only bidding energy into the market, and not ancillary services, the storage component has perfect round trip efficiency, and that the resource is not trying to conserve energy to prolong the life of the battery for future potential resource adequacy payments.

Based on the assumptions for this resource, the resource would never optimally bid a spread of prices between charge and discharge of the storage component for less than \$20/MWh. Unlike traditional gas fired generation, a scheduling coordinator will likely consider the opportunity cost for the storage component of generating energy. Opportunity costs may compel storage resources to bid to discharge at the lowest anticipated price energy might be sold at later in the day, which may correspond to the expected fourth highest price for energy during the day.

Because actual prices are unknown prior to the day ahead market, it is unclear what the specific bids for hybrid resource should be. Lower bids, or bids with little spread, result in the resource being scheduled more frequently, but subject the resource to greater changes in state of charge and may result in infeasible dispatch. Higher bids, or greater spreads, result in the resource being dispatched less frequently and potentially not capturing prices where it may be profitable for the resource to operate. There are many factors that need to be considered when a hybrid resource is bidding into the market, making bidding for these resources extremely complex. These considerations include: expected bids to charge and discharge, resource capabilities, interconnection limits, expected market prices, and expected dispatch from those market prices, expected state of charge resulting in operating a storage component in conjunction with expected output from an onsite variable energy component.

Figure 3 below illustrates how this resource could potentially bid into the market, and attempts to include some of the factors discussed above for hybrid resource bids. There are a number of things to note about the bids.

Outage Cards

This hybrid resource is not capable of producing to the 200 MW Pmax value during all intervals, and in fact can only produce to 100 MW, the maximum capability of the storage component, during intervals when there is no solar generation available. Note that this resource will use bids to signal typical unavailability of the variable component of the resource.¹² ~~submit outage cards for generation that it cannot produce for each hour.~~ For hours ending 1-9 and hours ending 20-24 the resource anticipates 0 MW of output from the solar component (denoted in the “expected solar” row) and therefore uses the upper range of the bid curve to signal the maximum resource capability during these hours of 100 MW. ~~enters an~~ Note, that there is no outage card submitted for generation between 100 MW and 200 MW during these hours. For hours ending 10-19, the resource is able to produce additional capacity because of expected

¹² Outage cards would be submitted to the outage management system for any prolonged outage due to mechanical issues.

solar generation, and that is noted by how the upper bound of the bids change during this time in the “outage above” row.

Bid Curves

This hypothetical hybrid resource has three distinct underlying components. Two are for the storage portion of the hybrid resource, including the charging portion of the battery (-100 MW to 0 MW) and the discharging portion of the battery (0 MW to 100 MW). Storage resources often bid charging capacity at prices they would be willing to buy energy at to charge the resource, and the discharging portion at prices that reflect a price they would be willing to sell energy at.

The final component is the solar resource. Most solar resources on the fleet today bid the full capacity of output between -\$15/MWh, which accounts for solar investment tax credits and \$5/MWh, which accounts for most operations and maintenance costs to operate the solar resource. In this example, we assume that the hybrid resource scheduling coordinator bids in the expected solar generation at a price of -\$15/MWh into the day-ahead market.

The bid curves in this example are split into 3 different periods of the day, intervals when the solar generation is expected to produce (in the morning and in the evening), and intervals when the solar generation is not producing. In the former periods the bid curve is two pieces, and represents the capabilities of the storage component of the hybrid resource. The latter bids are split into three components and include a bid for the expected solar generation and the storage generation.

The bid curves in the morning reflect prices that the hybrid resource is willing to charge the battery at, and prices that the hybrid resource is willing to discharge the storage component at. The storage component starts the day at 100 MWh, discharges during hour ending 8 when prices are relatively high, otherwise the resource maintains the same state of charge during this period.

Bidding from hour ending 10 through hour ending 19 reflects the bid curves for the storage component of the resource and the VER component of the resource. The size of the component of the bid curve corresponding to the renewable is equivalent to the expected average amount of energy that the renewable will generate. During this time period, the resource charges from 0 MWh to 400 MWh between hours ending 12 and 15 and begins to discharge during hour ending 19.

The final bid curve, used from hour ending 20 through the end of the day reflects the capability of the storage resource, and that the storage resource begins this period with 300 MWh of energy. The resource is discharged for an additional 300 MWh by the beginning of hour ending 23.

~~In the day-ahead market, the hybrid resource should enter outages during hours that the resource will not be available. In this example, when the sun is not shining the resource is not capable of generating above 100 MW, which prompts the resource to enter an outage card between 100 MW and 200 MW during these hours. Further, when there is some solar production expected, but not the full 100 MW, the resource enters outage cards for the~~

~~difference between the expected maximum amount of energy that can be generated and the Pmax of the resource. This changes every hour with the changes in expected output from the solar resource, and may also change with the state of charge of a storage component.~~

Figure 3: Example hybrid bids in the day-ahead market

	...	7	8	9	10	11	12	13	14	15	16	17	18	19	20	21	22	23	...
Expected Solar:	...	0	0	0	5	20	75	95	100	100	100	98	75	30	0	0	0	0	...
Expected DA Price:	...	\$30	\$45	\$35	\$25	\$20	\$22	\$15	\$15	\$24	\$27	\$32	\$37	\$52	\$55	\$75	\$58	\$30	...
Exp SOH En (MWh)	...	100	100	0	0	0	100	200	300	400	400	400	400	400	300	200	100	0	...
Bid (MW1)	...	-100	-100	-100	-100	-100	-100	-100	-100	-100	-100	-100	-100	-100	-100	-100	-100	-100	...
Bid (Price1)	...	\$18	\$18	\$18	(\$15)	(\$15)	(\$15)	(\$15)	(\$15)	(\$15)	(\$15)	(\$15)	(\$15)	(\$15)	\$18	\$18	\$18	\$18	...
Bid (MW2)	...	0	0	0	-95	-80	-25	-5	0	0	0	-2	-25	-70	-100	0	0	0	...
Bid (Price2)	...	\$40	\$40	\$40	\$23	\$23	\$23	\$23	\$23	\$23	\$23	\$23	\$23	\$23	\$40	\$40	\$40	\$40	...
Bid (MW3)	...	-	-	-	5	20	75	95	100	100	100	98	75	30	-	-	-	-	...
Bid (Price3)	...	-	-	-	\$40	\$40	\$40	\$40	\$40	\$40	\$40	\$40	\$40	\$40	-	-	-	-	...
Outage Above (MW)		100	100	100	105	120	175	195	-	-	-	198	175	130	100	100	100	100	...
Exp DA award	...	0	100	0	5	-80	-25	-5	0	100	100	98	75	130	100	100	100	0	...
		7	8	9	10	11	12	13	14	15	16	17	18	19	20	21	22	23	
Expected Solar:	...	0	0	0	5	20	75	95	100	100	100	98	75	30	0	0	0	0	...
Expected DA Price:	...	\$30	\$45	\$35	\$25	\$20	\$22	\$15	\$15	\$24	\$27	\$32	\$37	\$52	\$55	\$75	\$58	\$30	...
Exp SOH En (MWh)	...	100	100	0	0	0	100	200	300	400	400	400	400	400	300	200	100	0	...
Bid (MW0)	...	-100	-100	-100	-100	-100	-100	-100	-100	-100	-100	-100	-100	-100	-100	-100	-100	-100	...
Bid (Price1)	...	\$18	\$18	\$18	(\$15)	(\$15)	(\$15)	(\$15)	(\$15)	(\$15)	(\$15)	(\$15)	(\$15)	(\$15)	\$18	\$18	\$18	\$18	...
Bid (MW1)	...	0	0	0	-95	-80	-25	-5	0	0	0	-2	-25	-70	-100	0	0	0	...
Bid (Price2)	...	\$40	\$40	\$40	\$23	\$23	\$23	\$23	\$23	\$23	\$23	\$23	\$23	\$23	\$40	\$40	\$40	\$40	...
Bid (MW3)	...	100	100	100	5	20	75	95	100	100	100	98	75	30	100	100	100	100	...
Bid (Price3)	...	-	-	-	\$40	\$40	\$40	\$40	\$40	\$40	\$40	\$40	\$40	\$40	-	-	-	-	...
Bid (MW3)	...	-	-	-	105	120	175	195	200	200	200	198	175	130	-	-	-	-	...
Exp DA award	...	0	100	0	5	-80	-25	-5	0	100	100	98	75	130	100	100	100	0	...

Real-time bids must be submitted to the ISO 75-minutes prior to the start of the hour and must remain fixed for the entire hour. This means for hour ending 12, bids must be submitted no later than 09:45. Further, this also implies that the precise amount of state of charge for a hybrid resource is unknown at the time when bids are submitted. For hour ending 12, the ISO assumes that the example resource has a state of charge of 100 MWh (25% of full capacity) which matches the state of charge in the day-ahead market.

In the real-time market, assume that the solar resource is forecast to produce an average of just under 70 MW, slightly below the day-ahead forecast of 75 MW. Also assume that the solar is ramping up faster in the earlier part of the hour than in the later part of the hour as the sun is rising and the resource is ramping up to maximum output.

This example illustrates a three part bid in the real-time market, with the first segment of the bid curve starting at -100 MW at -\$15/MWh, the second portion of the bid curve at -30 MW at \$23/MWh, and the third segment of the bid curve at 35 MW at \$40/MWh. This implies that if locational marginal prices for this hybrid resource are below -\$15, the resource would be dispatched at -100MW, which implies solar would be reduced to 0 MW of output and the storage resource would charge from the grid as much as possible. At prices between -\$15/MWh and \$23 the resource would be dispatched at -30 MW. As solar generation is increasing throughout the hour, this implies a variable amount of charging from the storage component. Finally, at prices higher than \$40/MWh the hybrid resource discharges from the battery and produces from the solar component.

Because the output is variable during the hour, this hypothetical resource also employs the dynamic limit tool. The dynamic limit tool is sent to the ISO, at 5-minute granularity and must be updated in real-time as changes in output or forecast are known. The dynamic limits for each interval in hour ending 12 reflect what the storage resource is capable of producing (battery plus solar) during any specific hour. The dynamic limit tool may be used to indicate that no or limited output is available from the storage resource if the state of charge is 0 MWh or close to 0 MWh.

Figure 4 Example hybrid bids in the real-time market

		Hybrid - RT (HE 12)													
		...	11:00	11:05	11:10	11:15	11:20	11:25	11:30	11:35	11:40	11:45	11:50	11:55	...
Expected Solar:	35	45	54	60	65	70	75	79	83	86	88	89	
RT Price:	\$20	\$22	(\$10)	(\$10)	\$18	\$15	\$16	\$16	\$16	\$200	\$20	\$20	
Exp SOI En (MWh)	100	105.4	111.7	118.7	126.2	134.1	142.4	151.2	160.3	169.7	161.3	171.2	
Bid (MW1)	-100												
Bid (Price1)	(\$15)												
Bid (MW2)	-30												
Bid (Price2)	\$23												
Bid (MW3)	35												
Bid (Price3)	\$40												
Dynamic Limit	135	145	154	160	165	170	175	179	183	186	188	-	
Exp RT award	-30	-30	-30	-30	-30	-30	-30	-30	-30	186	-30	-30	
Battery Output (MW)	65	75	84	90	95	100	100	100	100	-100	100	100	
Solar Curtailment	-	-	-	-	-	-	5	9	13	-	18	19	

In most intervals during the hour locational marginal prices result in dispatch of this hypothetical resource consistently at -30 MW, except for the 11:45 interval, when the resource is dispatched to the 186 MW dynamic limit of the resource. Note that a -30 MW award implies that the storage resource is charging at different amounts during the hour, if the solar component is producing as much as possible during the hour. For example, the storage resource only charges at 75 MW during the 11:05 interval, while it charges at 90 MW during the 11:15 interval. Further, because the solar generation is very high at the end of the hour, and low at the beginning of the hour, these outputs and dispatch awards imply that the resource will curtail output from the solar component during the latter half of the hour when dispatch continues at -30 MW.

Because the resource is not fully charging at 100 MW for all intervals of the hour, it will not reach 200 MWh state of charge at the end of the hour, which was the result of the day-ahead market. It is further waylaid because of the unexpected high prices in the 11:45 interval. Suppose that the resource is able to predict the outcome of the real-time market, and desires a closer representation of these outcomes in the day-ahead market. A four segment bid curve may return a closer result to this outcome.

INVESTMENT TAX CREDIT

Many stakeholders commented that the investment tax credit (ITC) is critical to receiving financing for utility scale storage products. The tax credit available is reduced in proportion to the amount of energy that the storage resource charges from the grid compared to the amount of energy charged from onsite renewable resources. Where more generation from the grid implies less availability of investment tax credit. Some resources plan to simply model the storage component as being unavailable to charge from the grid, and indeed some have signed agreements that the storage resource will never charge from the grid.

The ISO understands the critical need to secure funding to build these projects, but encourages resource developers to offer available capacity to the grid when possible. DMM provided comments about the loss of efficiency from having a resource, or a portion of a resource not available to the market for dispatch. The ISO takes the same view and believes that it is much better to have a resource bid into the market at very low prices, in the case of storage resources charging, so that the ISO may access the resource in the charging capacity from the resource in the event that there is energy curtailment, to the point that the prices are set at the ISO floor. This helps the ISO avoid scarcity pricing and helps the ISO operations team manage the grid reliably.

Although the precise amount of revenue may not be something that can be calculated, a good approximation can be developed, and resources will be eligible to bid those prices into their bid curves. In a very easy example, suppose a hypothetical 100 MW 4-hour storage project has an annualized cost of \$30 million, and is eligible for \$10 million in investment tax credit if the

resource does not charge at all from the grid.¹³ Further assume that the battery will perform 1 4-hour cycle per day for a total of 100 MW * 4 hours * 365 days = 146 GWh. Finally, assume that there are no round-trip efficiency losses associated with the battery charging and discharging.

From these assumptions it is possible to determine what the marginal cost of charging for one additional megawatt-hour from the grid would be. The additional hour would result in the total energy for the resource increasing from 146,000 MWh to 146,001 MWh, or roughly an additional .0007%. This ratio corresponds to about \$68/MWh (\$10,000,000 * .0007%). Therefore if the resource did buy energy from the grid, and was typically valued charge energy at \$23/MWh, i.e. was willing to forego prices of \$23/MWh or below in the energy market to charge the resource from onsite solar, then the resource should be indifferent between charging from the grid anytime prices are lower than -\$50/MWh (\$18/MWh - \$68/MWh).

A storage resource bidding in such a way is illustrated in Figure 5. This hypothetical resource is willing to charge from the grid anytime prices are less than -\$50/MWh and willing to discharge anytime prices are greater than \$40/MWh. In this example the actual realized real-time price at 06:30 is -\$150/MWh, which could be the result of a local generator tripping on the grid. During this interval the resource is dispatched to charge at 100 MW. During the other intervals the resource is not dispatched to charge or discharge because the other actual prices are between \$10/MWh and \$30/MWh. If the storage resource was not receiving investment tax credit, it may be optimal for the resource to charge at 06:45, when prices are relatively low at \$10/MWh.

Figure 5 Storage resource or component receiving an investment tax credit

	...	6:00	6:05	6:10	6:15	6:20	6:25	6:30	6:35	6:40	6:45	6:50	6:55	...
Expected Solar:	...	0	0	0	0	0	0	0	0	0	0	0	0	0
RT Price:	...	\$28	\$30	\$27	\$29	\$32	\$28	(\$150)	\$24	\$30	\$10	\$29	\$25	
Exp SOI En (MWh)	...	100	100	100	100	100	100	100	108.3	108.3	108.3	108.3	108.3	
Bid (MW1)	...	-100												
Bid (Price1)	...	(\$50)												
Bid (MW2)	...	0												
Bid (Price2)	...	\$40												
Exp RT award	...	0	0	0	0	0	0	-100	0	0	0	0	0	0
Battery Output (MW)	...	0	0	0	0	0	0	100	0	0	0	0	0	0

A number of simplifying assumptions were made in this example. The ISO acknowledges that each resource on the grid is different and each resource has unique operating characteristics and financial considerations. If a resource is unable to bid costs associated with generation

¹³ Assume the low cost projection: <https://www.nrel.gov/docs/fy19osti/73222.pdf>.

from the grid into the market, the ISO may make special allowances for these resources to not show that capacity in the market. To the extent that resources are able to bid into the real-time market in a way that captures the investment tax credit, the ISO is encouraging those resources to do that.

4.13. Resource adequacy

The resource adequacy (RA) counting rules and must offer obligations for hybrid resources are vital to ensuring that hybrid resources can participate in ISO markets and support system and local reliability.

Local regulatory agencies (LRAs) determine counting rules to determine resource adequacy capacity. The ISO then takes this information and studies resources for their deliverability, and may reduce the amount of capacity each resource may qualify for. After this value is established load serving entities (LSEs) then compose supply plans with resources in order to meet their capacity obligations. Shown resources are then subject to ISO's provisions on availability, through the must offer obligation (MOO).

Counting rules and must offer obligations are already in place for individual resources that could be co-located. The ISO is not proposing any changes to the resource adequacy framework, including must offer obligations or resource adequacy availability incentive mechanism (RAAIM) exposure, for co-located resources at this time.

Any counting rules applied to hybrid resources may have impacts on ISO markets and operations. The ISO believes that RA counting rules should provide fair and accurate capacity valuations, as these rules will impact interconnection configurations and ISO visibility into resources that are operated on the system. The CPUC established a process to determine counting rules through workshops with stakeholders in their resource adequacy track 2 proceeding.¹⁴ The ISO intends to retain the methodology that was outlined by the CPUC as this policy is implemented. However, the ISO is concurrently working on policy in the resource adequacy enhancements initiative which includes major changes to the counting rules for most resources, including hybrids.¹⁵ This new counting methodology will use an unforced capacity (UCAP) methodology and will be in place for the 2023 resource adequacy year.

The ISO currently requires that non-generator resources be subject to a 24x7 must offer obligation, similar to most resources in the fleet today. The ISO recognizes that hybrid resources with storage components will likely have multiple hours during the day while they are using on-site generation to charge storage components and that a significant portion of the resources capacity may not be available for dispatch during these times. This will likely result in periods when the resource is incapable of bidding all capacity into the market. During these hours the hybrid resources will have access to ~~outage cards~~ the dynamic limit tool in the real-

¹⁴CPUC Decision, June 25, 2020, Section 3.4.2:

<https://docs.cpuc.ca.gov/PublishedDocs/Published/G000/M342/K083/342083913.PDF>.

¹⁵Resource Adequacy Enhancements initiative:

<https://stakeholdercenter.caiso.com/StakeholderInitiatives/Resource-adequacy-enhancements>.

time market, that which may be used to alert the ISO that these resources are unavailable to the market.

~~Like other resources, the hybrids resource adequacy availability incentive mechanism will assess if the applies to most resources on the grid today, and is meant to incentivize these resources to resource is bidding all or partial capacity shown as resource adequacy capacity into the market during the availability assessment hours. In the event that at the resource is not bidding its full resource adequacy capacity into the market during these hours, the resource will face will be assessed resource adequacy availability assessment penalties. Likewise, the resource w may receive receive incentive payments if it does bid resource adequacy capacity into the market during the availability assessment hours charges, similar to other resources. Hybrid resources are different than most resources that are subject to the resource adequacy incentive mechanism is applied to. The capacity values for hybrid resources are is set using an electric load carrying capability (ELCC) methodology applied to the variable portion of capacity for the resource. This methodology is also applied to stand alone variable energy resources on our system. Variable energy m, and these resources are not subject to the resource adequacy availability incentive mechanism because their marginal costs are generally very low and these resources have little incentive to withhold energy. Although hybrid resources are not variable, their variable components have similar economics as stand-alone variable energy resources. and likely should not be exposed to penalties in the resource adequacy availability incentive mechanism. However, stand-alone storage resources are exposed to this mechanism and have different economics and incentives. As t The ISO expects that most hybrid resources in the next few years will be a combination of variable energy and storage components. Differentiating between the two components for the purpose of assessing the availability of the overall resource under the resource adequacy availability incentive mechanism would be unduly burdensome. , the ISO proposes to not expose these resources to the resource adequacy availability incentive mechanis. Although it might be appropriate to apply this mechanism to the storage components technically, it may be difficult to determine when these portions of the total resource are unavailable. Further, this treatment is appropriate. In addition, the CAISO plans to retire as the resource adequacy availability incentive mechanism is on track to be retired in January 2023, with the implementation of the unforced capacity counting methodology. For these reasons, the ISO proposes to not apply the resource adequacy availability incentive mechanism to these resources. proposed by in the resource adequacy enhancements stakeholder initiative. At this time the ISO is not anticipating additional changes to the resource adequacy availability incentive mechanism tool. This will imply that outages from unavailability from dynamic limits, will not be subject to this tool.~~

~~For example, if a hybrid resource is comprised of a 100 MW solar resource and a +/- 50 MW 4-hour storage resource with a 100 MW interconnection limit. During the peak solar hours, there may be intervals when the solar is forecast to produce at a consistent output of 80 MW for several hours. At that time, the scheduling coordinator plans to use a portion of that output to charge the on-site battery (at a full 50 MW). This results in a new capability of the hybrid facility to provide no more than 30 MW to the ISO grid. In this case, the hybrid resource would be required to enter an outage card for 50 MW to account for the unavailability of the storage resource, with an additional 20 MW of unavailability entered through the dynamic limit tool to~~

~~indicate that the solar resource is incapable of producing the full 100 MW of output, and instead is only capable of producing 80 MW of output. This will provide the ISO visibility that the hybrid resource is only capable of generating between 0 MW and 30 MW, considering energy that will or could be delivered to the grid. If the forecast solar availability changes during the charging periods, the resource would continue to update the ISO to new availability via the dynamic limit tool. Updates submitted through the dynamic limit tool would not be subject to resource adequacy availability assessment mechanism, but outage cards of this nature would be.~~

As noted above, the ISO will have access to forecast data, and will continue to monitor bidding and availability for hybrid resources, as they are integrated onto the ISO system.

5. EIM Governing Body Role

This initiative proposes to modify market rules that apply generally to the real-time market to facilitate participation by hybrid resources, including rules governing interconnection, providing ancillary services, metering and a range of other topics. Staff believes the EIM Governing Body should have an advisory role in the approval of the proposed changes.

The rules that govern decisional classification were amended in 2019 when the Board adopted changes to the Charter for EIM Governance and the Guidance Document. An initiative proposing to change rules of the real-time market now falls within the primary authority of the EIM Governing Body either if the proposed new rule is EIM-specific in the sense that it applies uniquely or differently in the balancing authority areas of EIM Entities, as opposed to a generally applicable rule, or for proposed market rules that are generally applicable, if “an issue that is specific to the EIM balancing authority areas is the primary driver for the proposed change.”

Staff believes the EIM Governing Body should have an advisory role in the approval of the proposed changes for two reasons. First, the proposed rule changes would apply generally and uniformly across the entire ISO footprint— there will not be any EIM-specific rules. Second, the primary driver for the hybrid resources initiative is the need for hybrid resources, including co-located resources, to meet the need for additional RA in the ISO’s balancing authority area after the loss of resources that use once-through cooling. The driver is not an EIM issue.

If any stakeholder disagrees with this proposed classification, please include in your written comments a justification of which classification is more appropriate.

6. Next Steps

The ISO will discuss the final proposal for hybrid resources during a stakeholder teleconference on October 15, 2020 at 10am. Stakeholders are asked to submit written comments by October 29, 2020 to initiativecomments@ISO.com. A comment template will be available at: <http://www.ISO.com/informed/Pages/StakeholderProcesses/HybridResources.aspx>.